

16 oz COTTON WASH

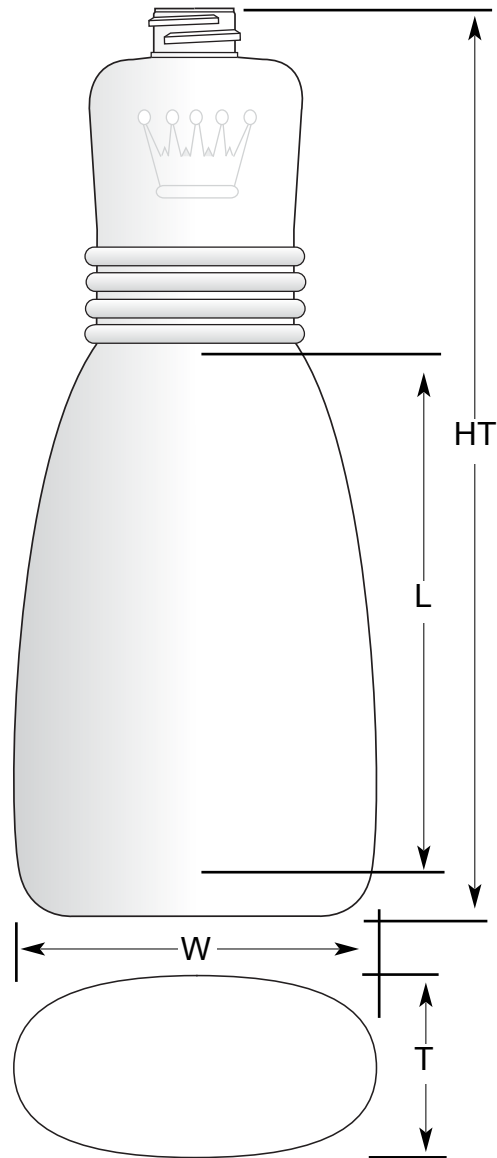

NOTE: Illustration at 1/2 size

For label dimensions or production line set up actual samples should be used.

I T E M S P E C I F I C A T I O N									
CODE	CAPACITY	FINISH	RESIN	WEIGHT	HEIGHT (HT)	WIDTH (W)	THICKNESS (T)	LABEL (L)	QTY/CTN
1CW16-N16	16 oz	26/103	HDPE	38 gm	9.480"	3.650"	1.900"	4.500"	224

Ocean State Packaging
(401) 884-4400