

3

2

1

SECTION A-A
SCALE 5 : 1

58-SP400
PITCH: .167 TPI:6
THREAD TURNS: 1

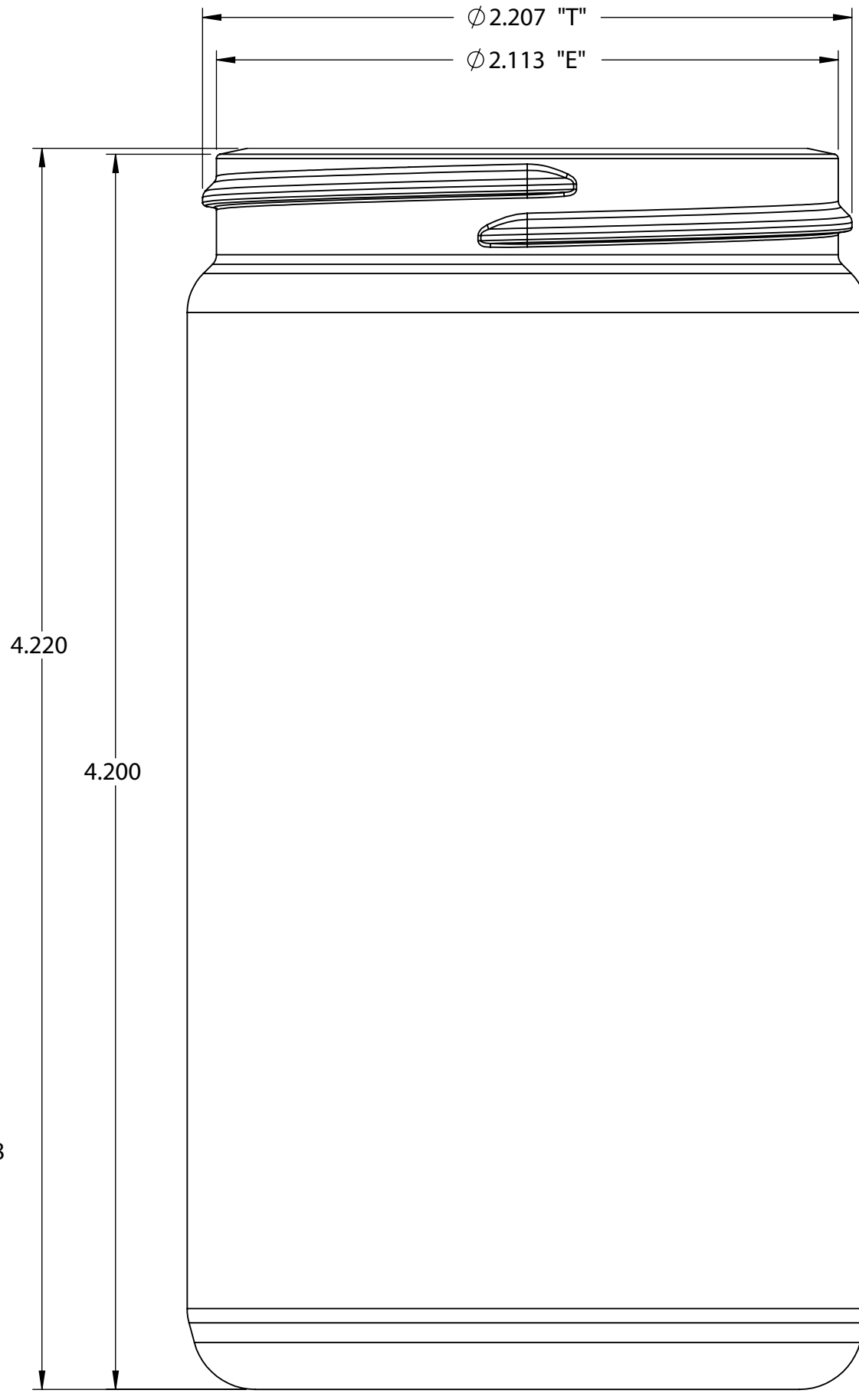
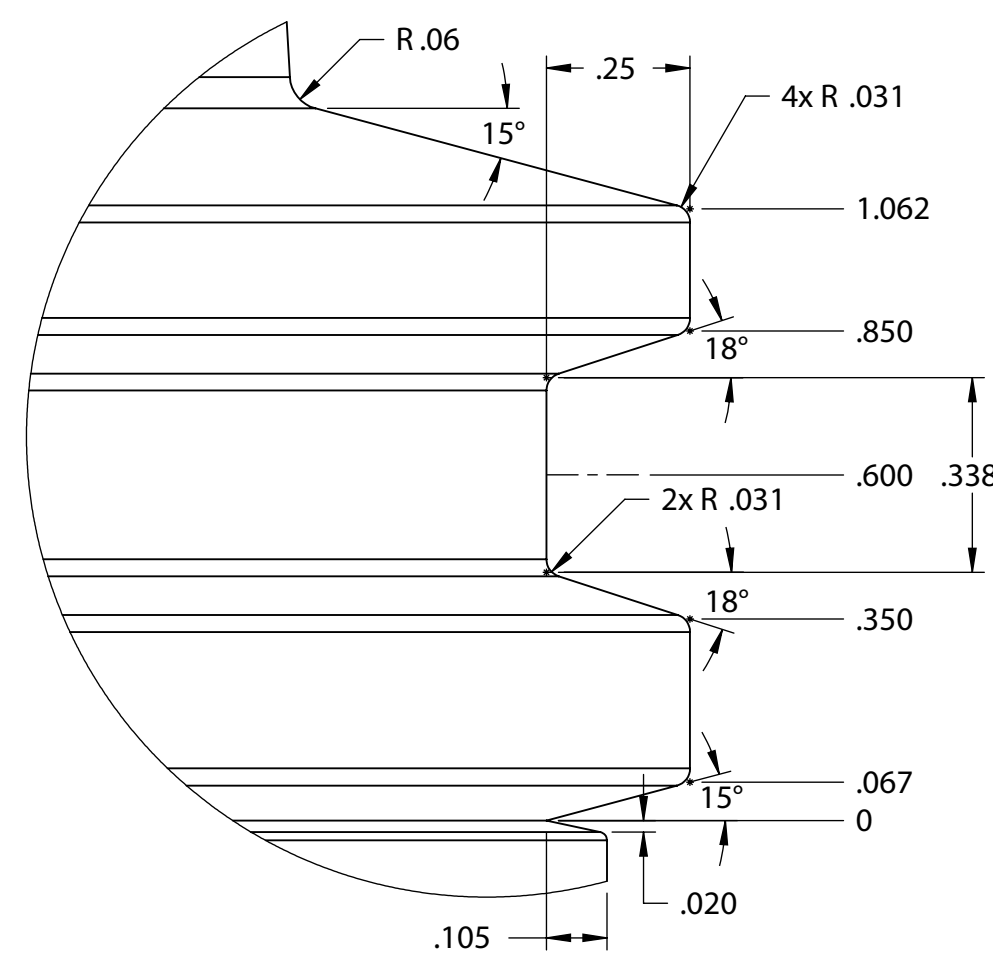
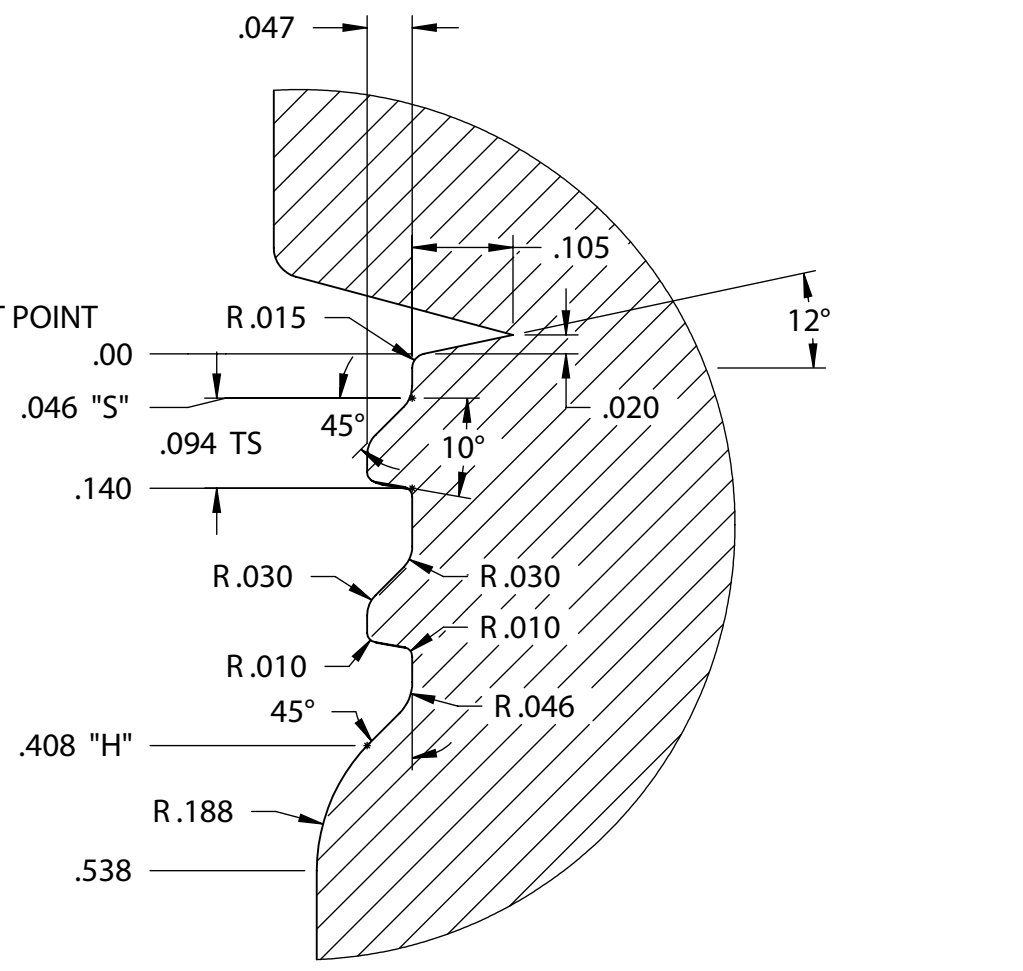
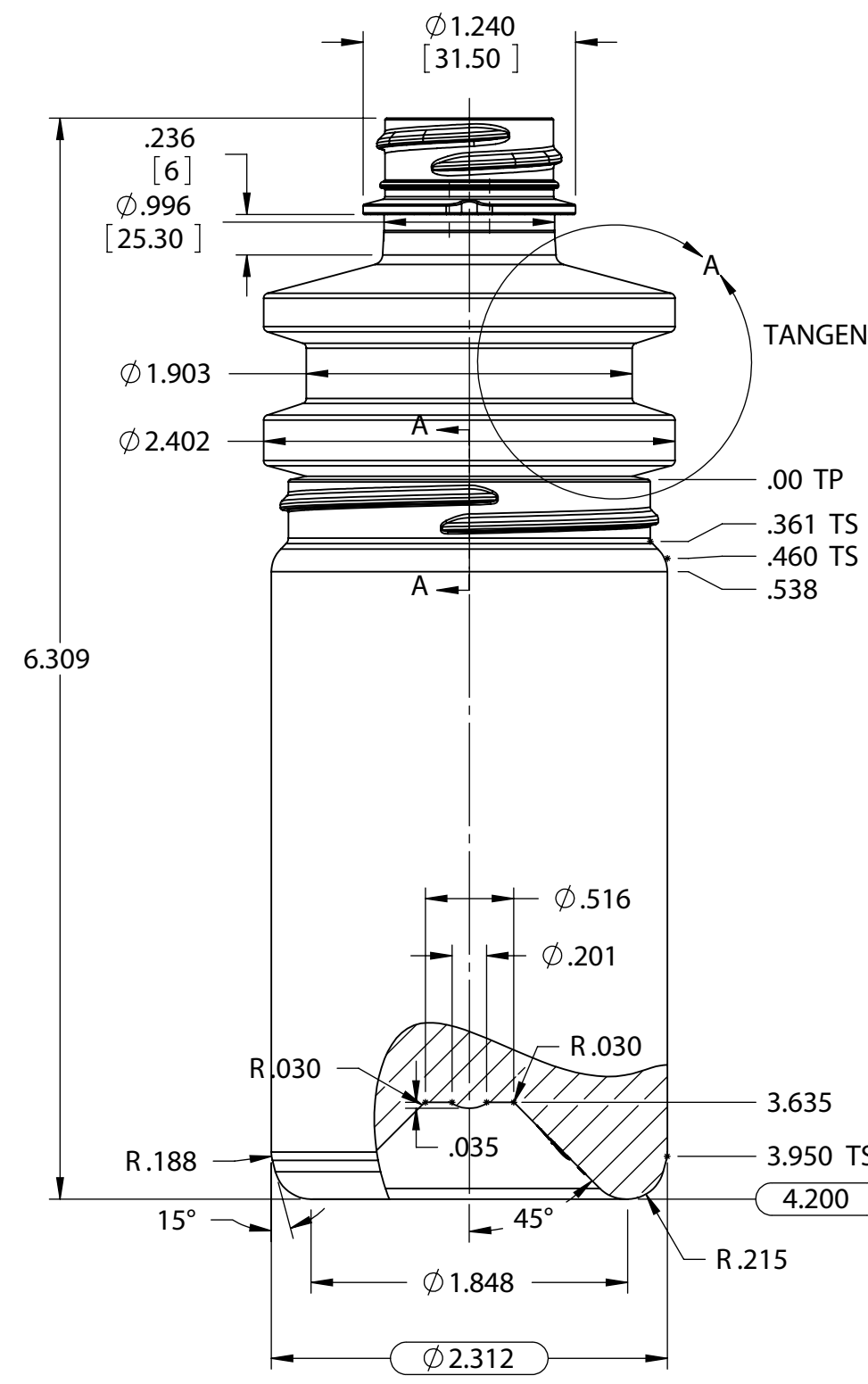

APPROXIMATE BOTTLE WEIGHT: 20g
OVERFLOW CAPACITY: 259.65cc ± 7.1cc

ALL CALCULATIONS & VOLUMES APPROXIMATE UNTIL MANUFACTURE

DETAIL VIEW
SCALE 2 : 1

ALL DIMENSIONS FOR REFERENCE ONLY
*******USE 3-D MODEL PROVIDED*******

1. ALL NOTES APPLIED UNLESS OTHERWISE SPECIFIED
2. ALL TAP DEPTH DIMENSION ARE GIVEN AS FULL THREADS
3. ALL DOWEL DEPTHS ARE GIVEN TO FULL DIAMETER
4. ALL DRILL DEPTHS ARE GIVEN TO THE DRILL POINT
5. BREAK ALL SHARP EDGES .01X45

25/08/2008

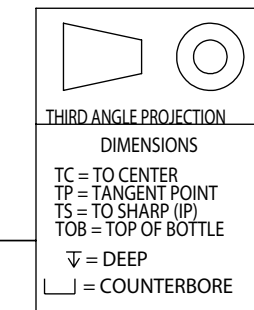

CONFIDENTIAL	MATL: PETE	FINISH: PREFORM 28-SP400
THIS DRAWING AND THE INFORMATION HEREIN ARE CONFIDENTIAL AND NOT TO BE DISCLOSED WITHOUT THE EXPRESS CONSENT OF MOLD-SPEC INC.	DTL BY: DK	Ocean State Packaging (401) 884-4400
	DATE: 14AUG08	
	MD'L BY: DK	
	DATE: 14AUG08	
CUSTOMER: M-CORP	PROD. No.	
PRODUCT: GARLIC BOTTLE	MACHINE	
TITLE: GARLIC BOTTLE		
SCALE: 1:1 & NOTED	JOB No. MS-4377A	DWG No. C-4377A-1
SHEET 1 OF 1		REV. 0

3

2

1