

NECK FINISH	BOTTLE WEIGHT (± 2 GR)	OVERFLOW CAPACITY (± 13 CC)	"T" DIA	"E" DIA	"H" DIM	"S" DIM	"I" DIA	MATERIAL
33-400	52.0	722.2	1.265 1.241	1.171 1.147	.418 .388	.061 .031	1.132 1.108	PETE

DATE	SYM	REVISION RECORD	AUTH	DR	CK
2/11/14	A	020414 ID WAS 020214		DC	
		ADDED NOTES			

NOTES:  
 PITCH - .167  
 6 THREADS PER INCH  
 ONE FULL TURN OF THREAD  
 "M" STYLE THREAD PROFILE

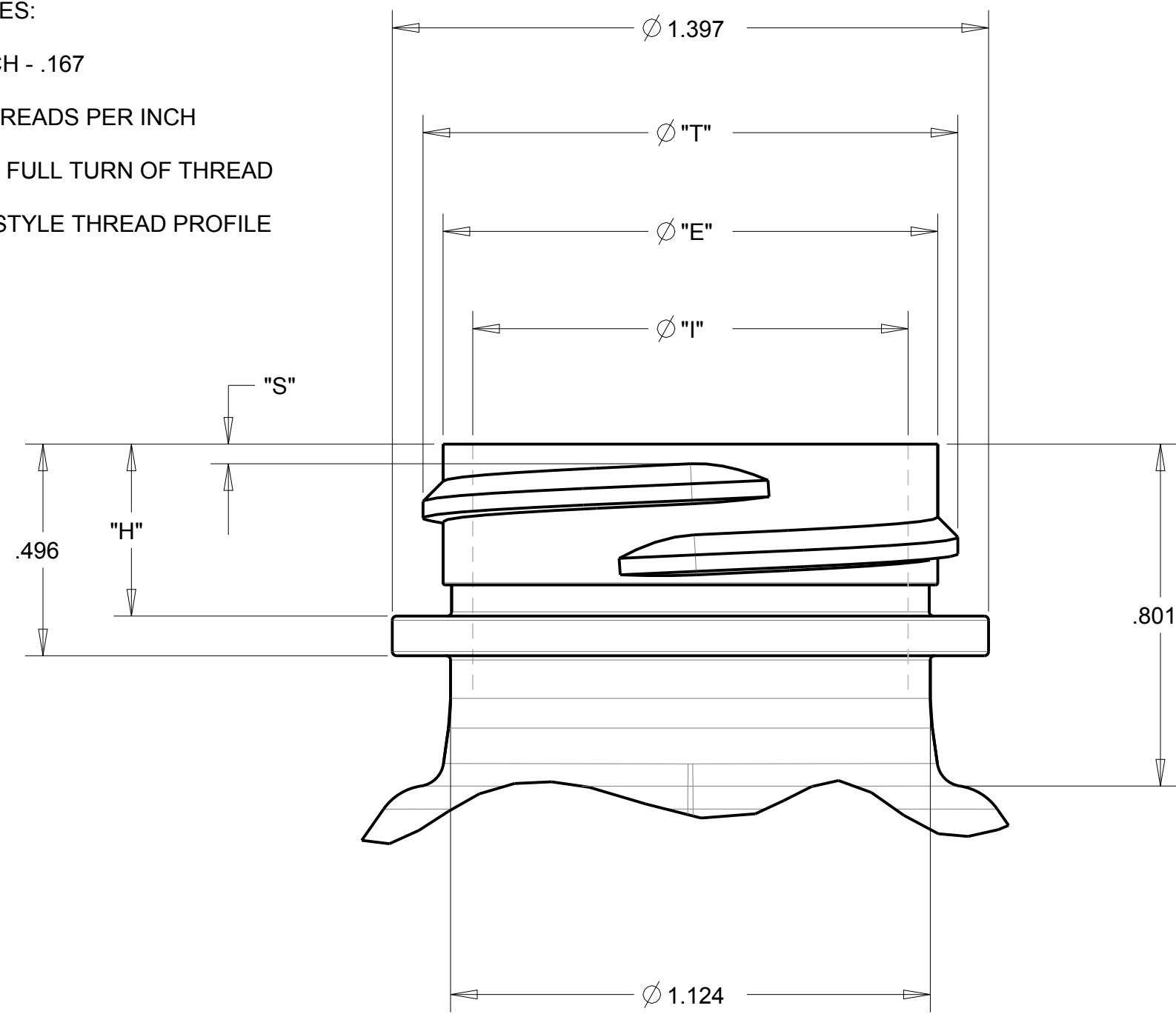

DETAIL A  
 SCALE 3.000

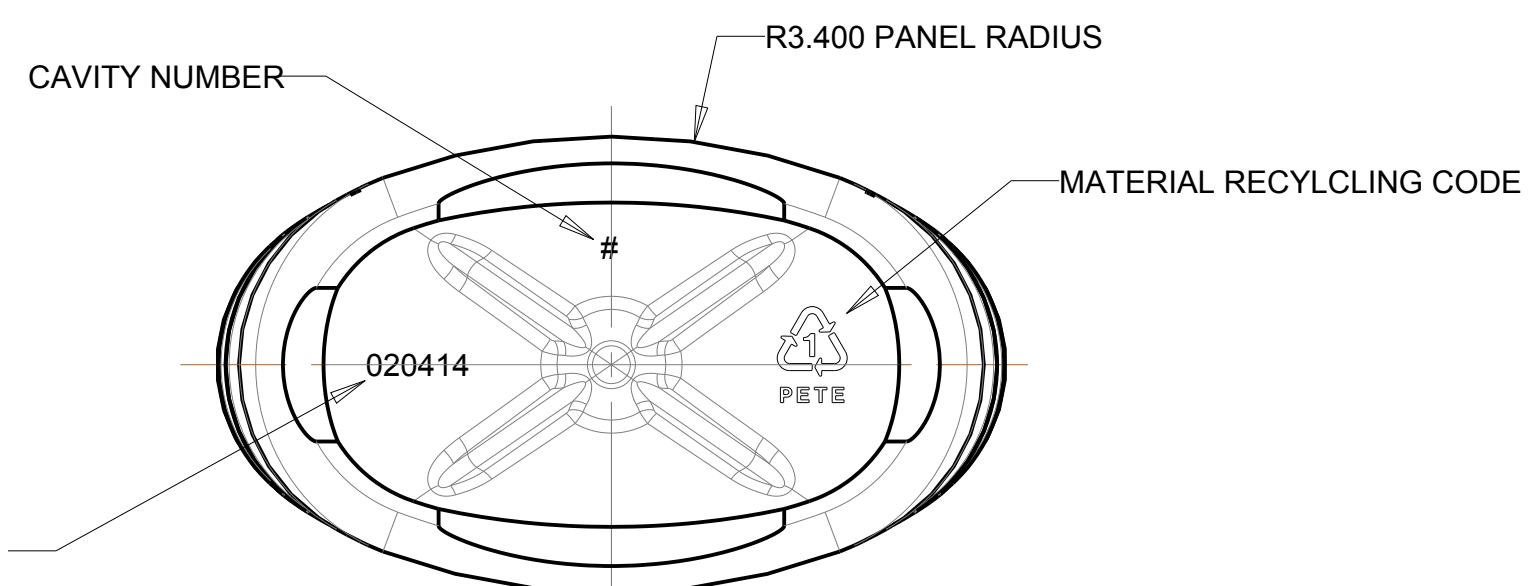
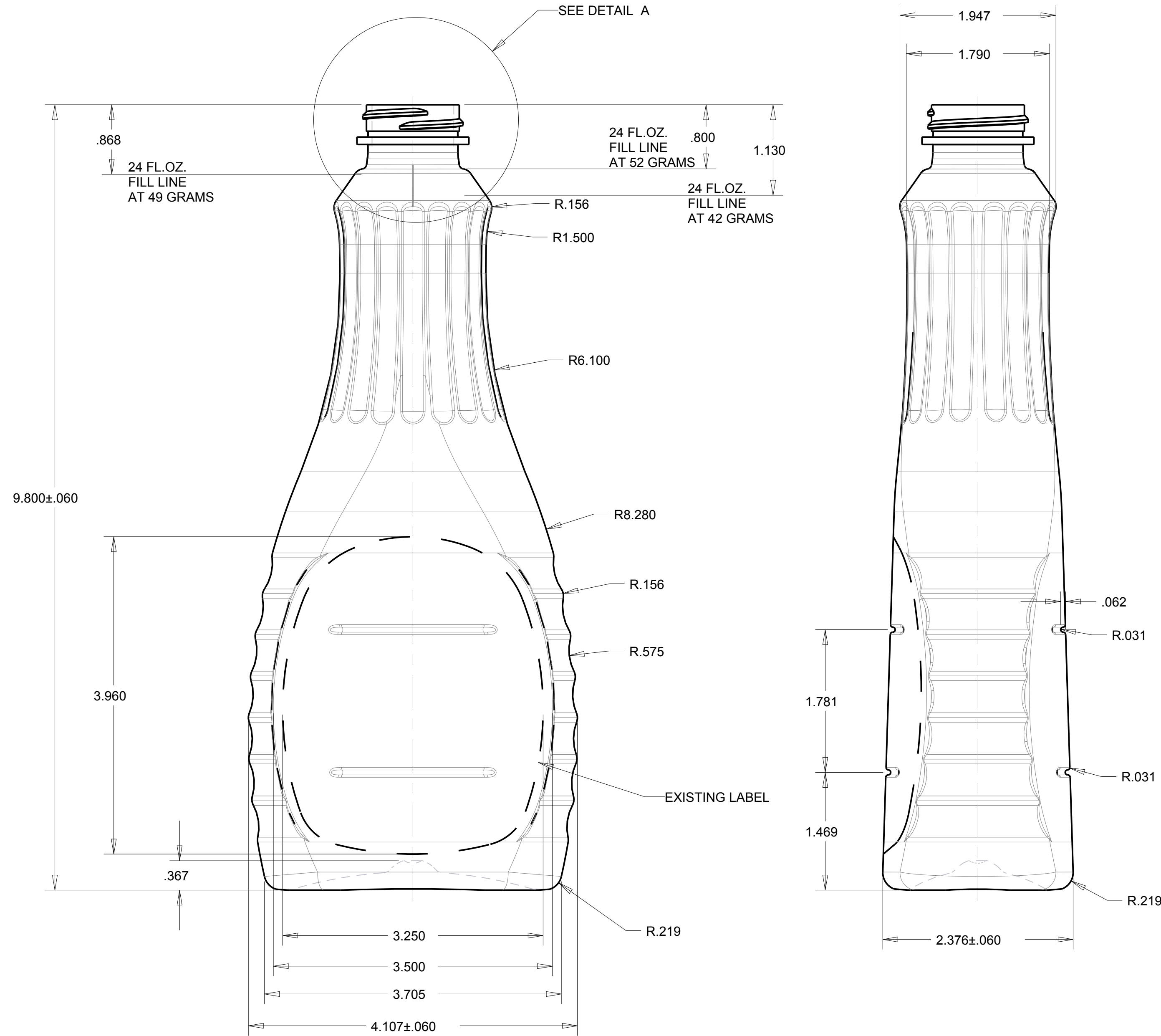
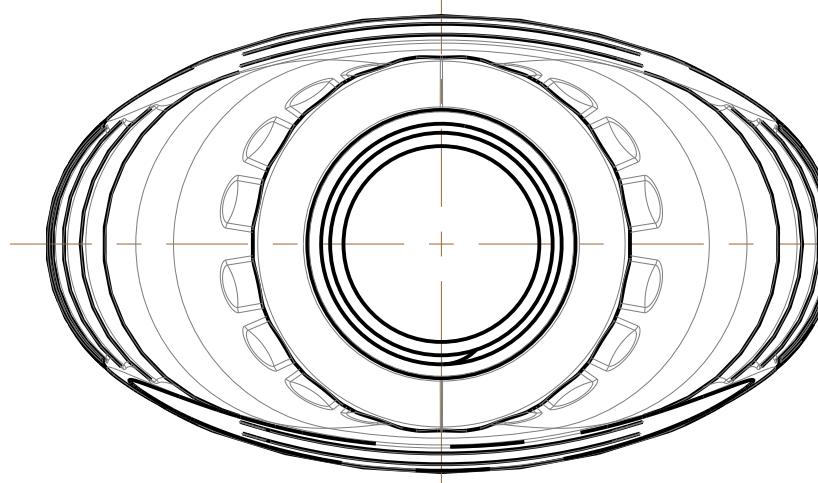

MOLD IDENTIFICATION NUMBER

TOLERANCES (EXCEPT AS NOTED)				
DECIMAL	MATERIAL	SCALE	DRAWN BY	KSN
	PETE	FULL	APPROVED BY	
FRACTIONAL	TITLE	24OZ. SYRUP		
ANGULAR	DATE	DRAWING NUMBER	REVISION	MOLD NO.
	1/27/14	SS-1268-OS	A	