

NECK FINISH	BOTTLE WEIGHT ±2 GRAMS	OVERFLOW CAPACITY ±11 CC	"T" DIA.	"E" DIA.	"H" DIM.	"S" DIM.	"I" DIA.
22-400	42.0	402.0	.862 .846	.778 .762	.483 .453	.052 .022	.483 MIN.

DATE	SYM	REVISION	BY

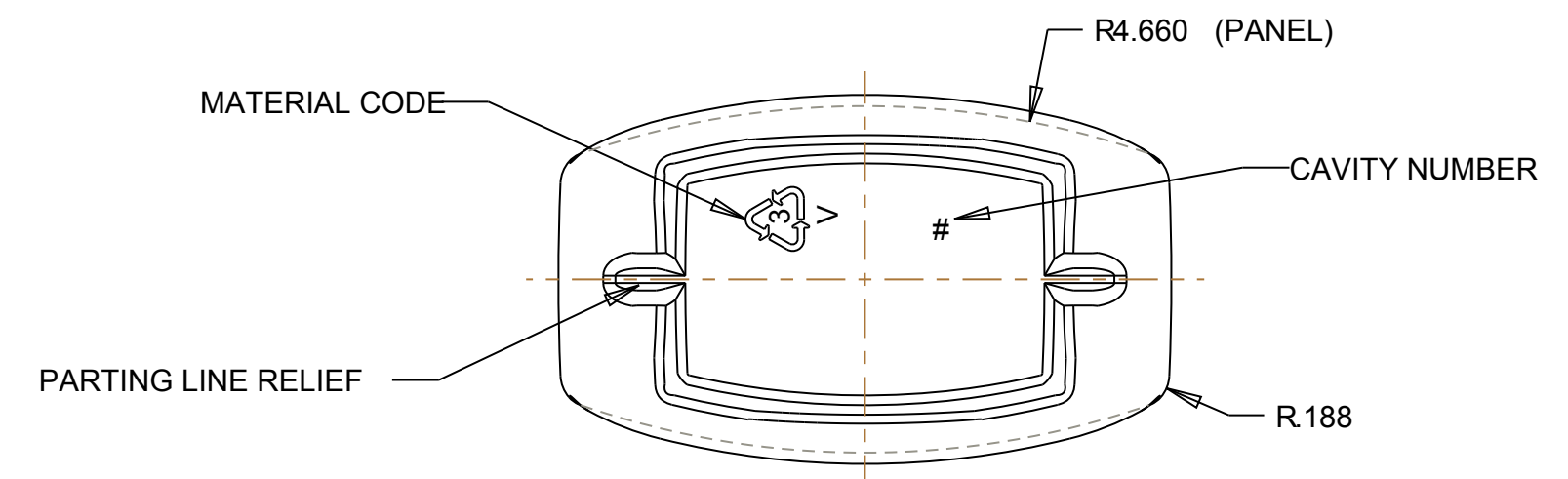
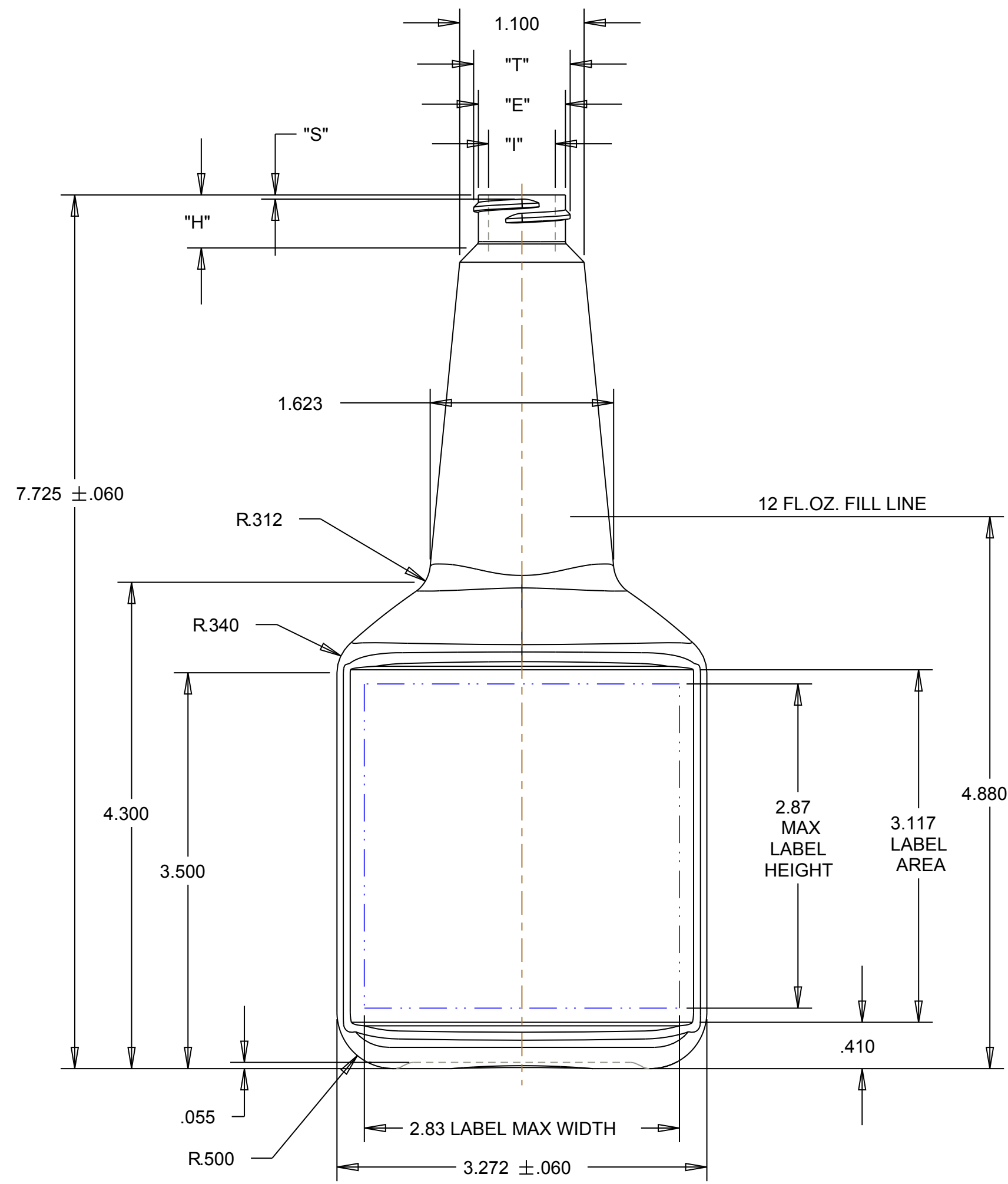
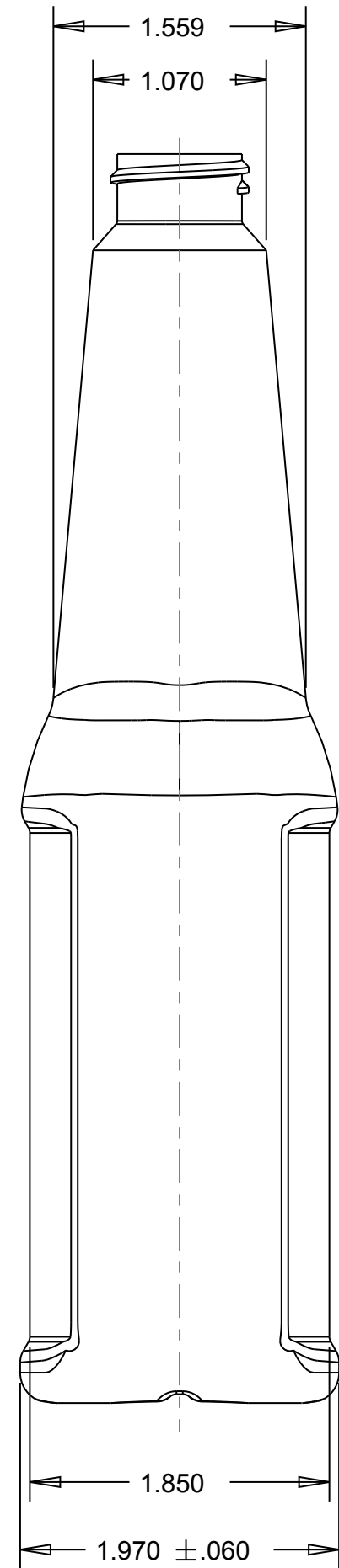
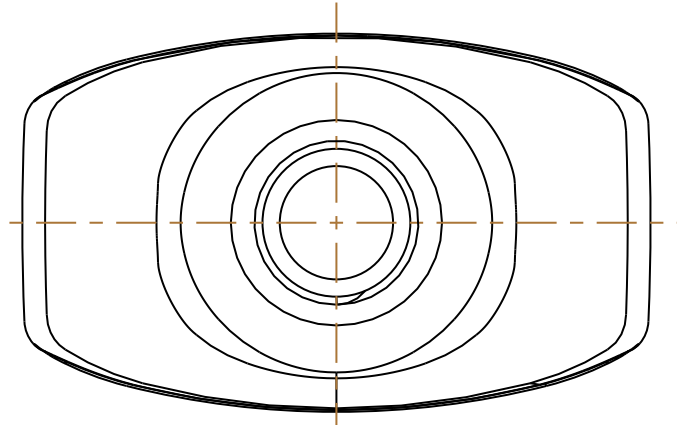

<b>OCEAN STATE PACKAGING</b> EXTRUSION AND INJECTION BLOW MOLDED BOTTLES			
TOL	TITLE		
S.P.I.	12 OZ. FUEL ADDITIVE		
DATE	DRAWING NO.	REV	
9/12/12	SS-1199-OS		