

NECK FINISH	BOTTLE WEIGHT ±2 GRAMS	OVERFLOW CAPACITY ±11 CC	"T" DIA.	"E" DIA.	"H" DIM.	"S" DIM.	"I" DIA.
22-400	46.0	458.0	.862 .846	.778 .762	.465 .435	.052 .022	.483 MIN.
33-400	46.0	460.5	1.265 1.241	1.171 1.147		.061 .031	.791 MIN.

DATE	SYM	REVISION	BY
10/19/12	A	ADDED 15 FL.OZ. FILL LINE	KSN
		CHANGED DESCRIPTION FROM 12 OZ TO 15 OZ	

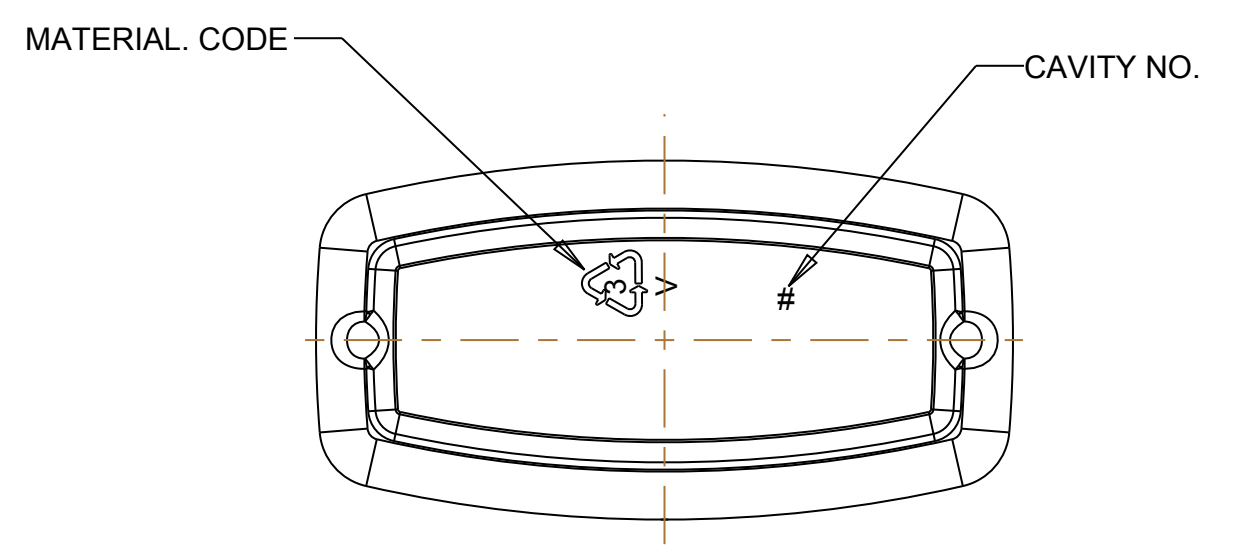
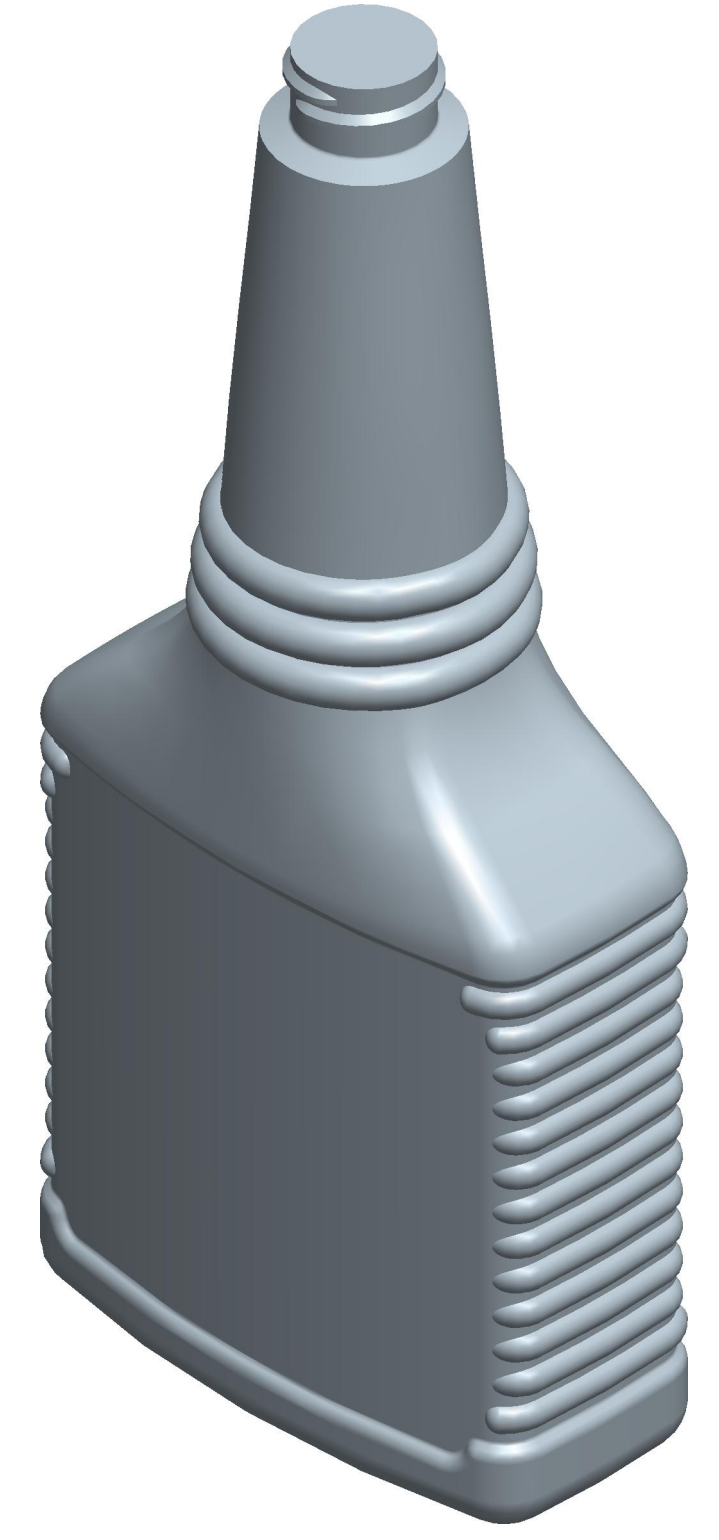
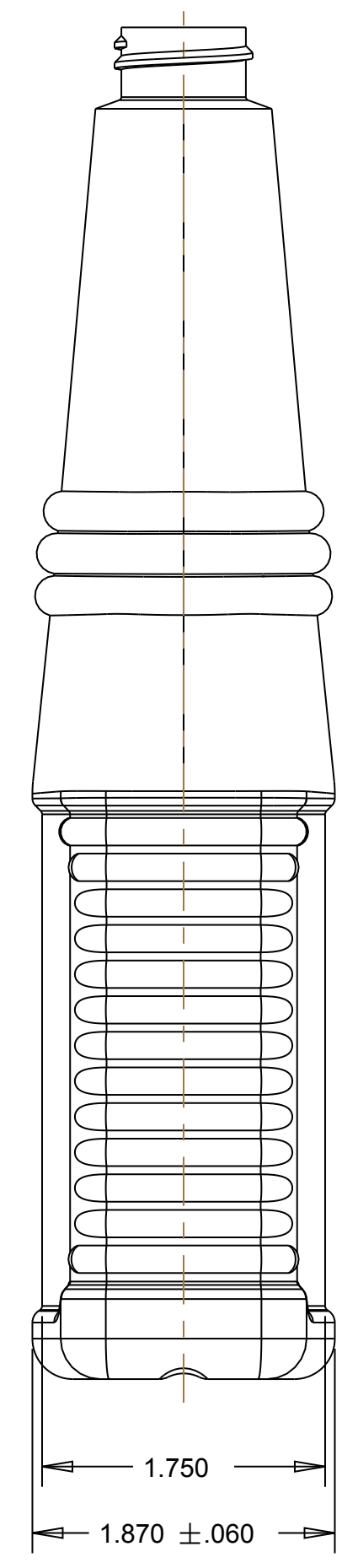
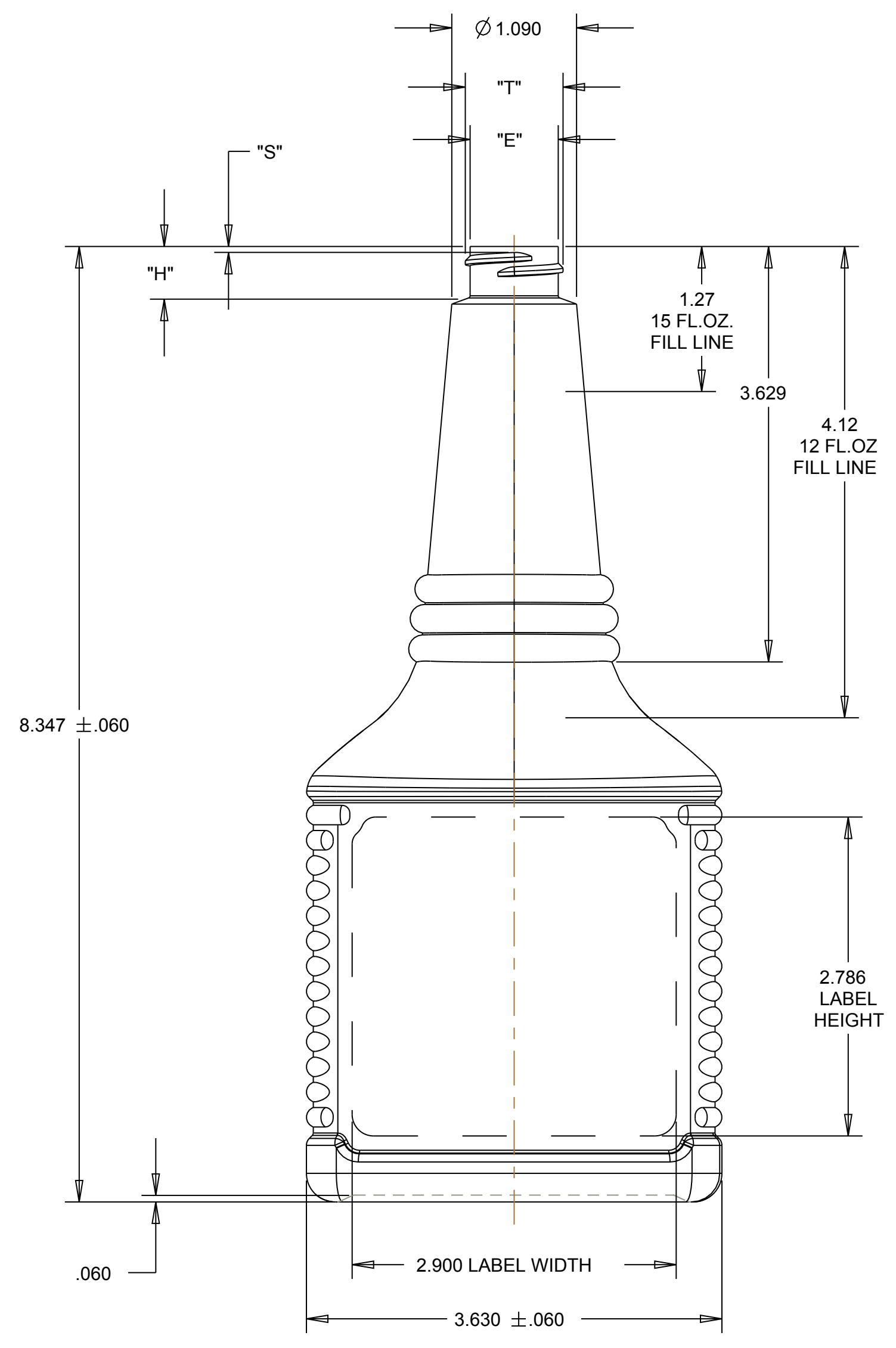
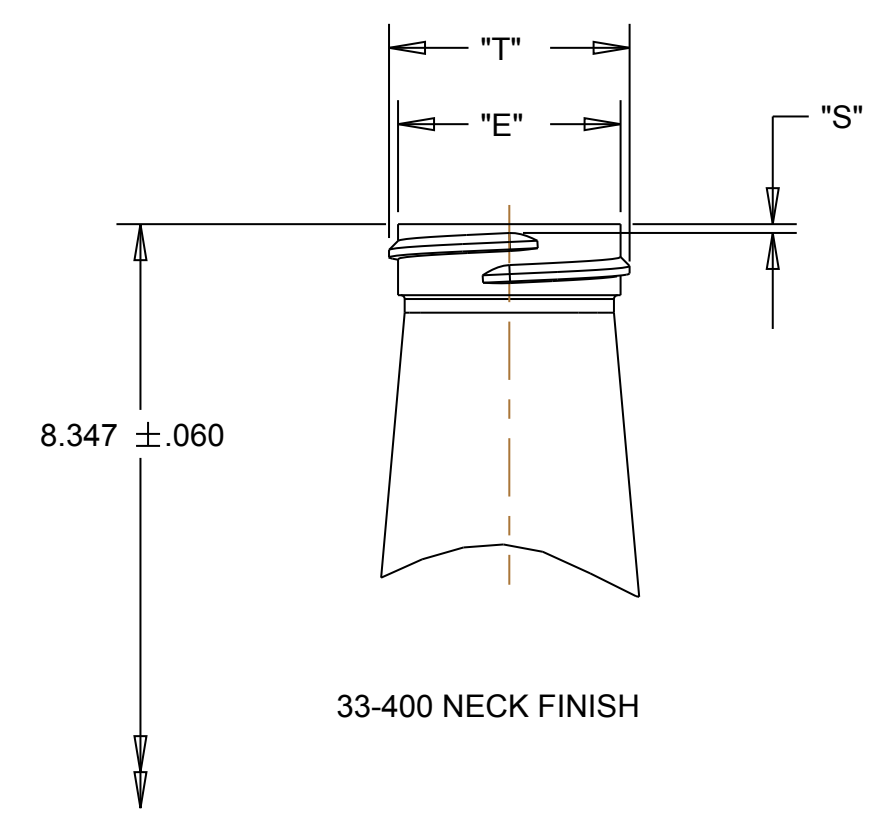
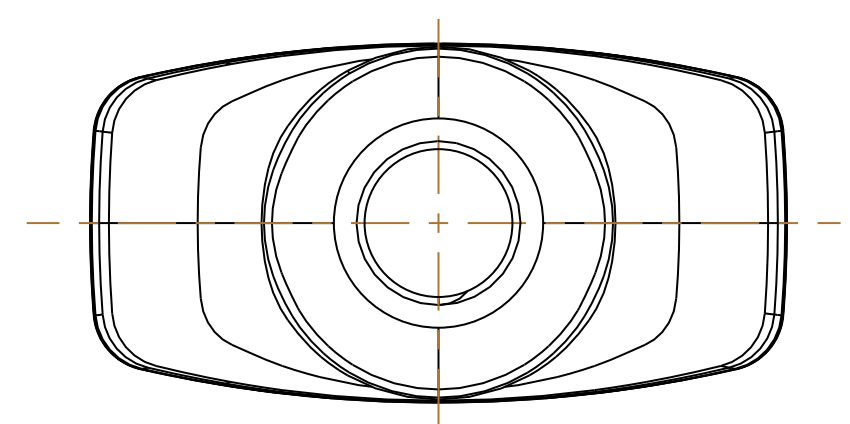

<b>OCEAN STATE PACKAGING</b> EXTRUSION AND INJECTION BLOW MOLDED BOTTLES			
TOL	TITLE		
S.P.I.	15 OZ. FUEL ADDITIVE		
DATE	DRAWING NO.	REV	
10/17/12	SS-1206-OS	A	