

NECK FINISH	BOTTLE WEIGHT ±1.5 GRAMS	OVERFLOW CAPACITY ±5 CC	"T" DIA.	"E" DIA.	"H" DIM.	"S" DIM.	"I" DIA.
M24SP410	12.0	129.3	.940 .924	.856 .840	.661 .631	.061 .031	.516 MIN.

DATE	SYM	REVISION	BY
4/3/13	A	ADDED MOLD NO. TO BASE ENGRAVING	KSN

NOTES:

1. MATERIAL - PVC
2. 8 THREADS PER INCH

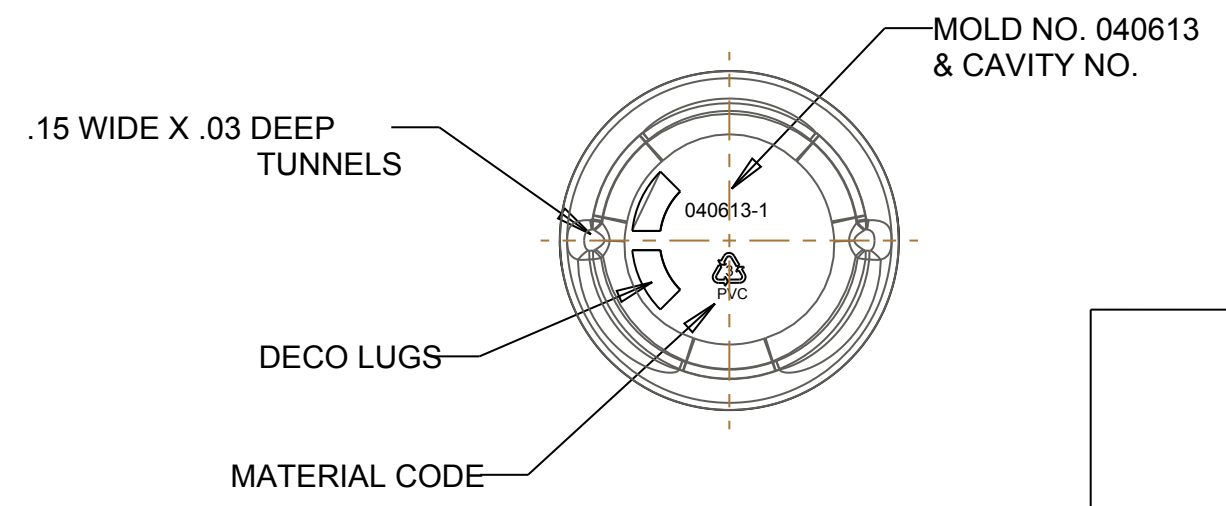
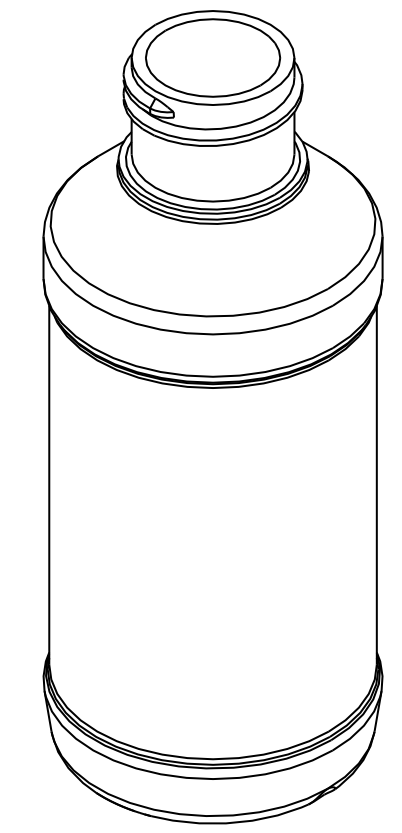
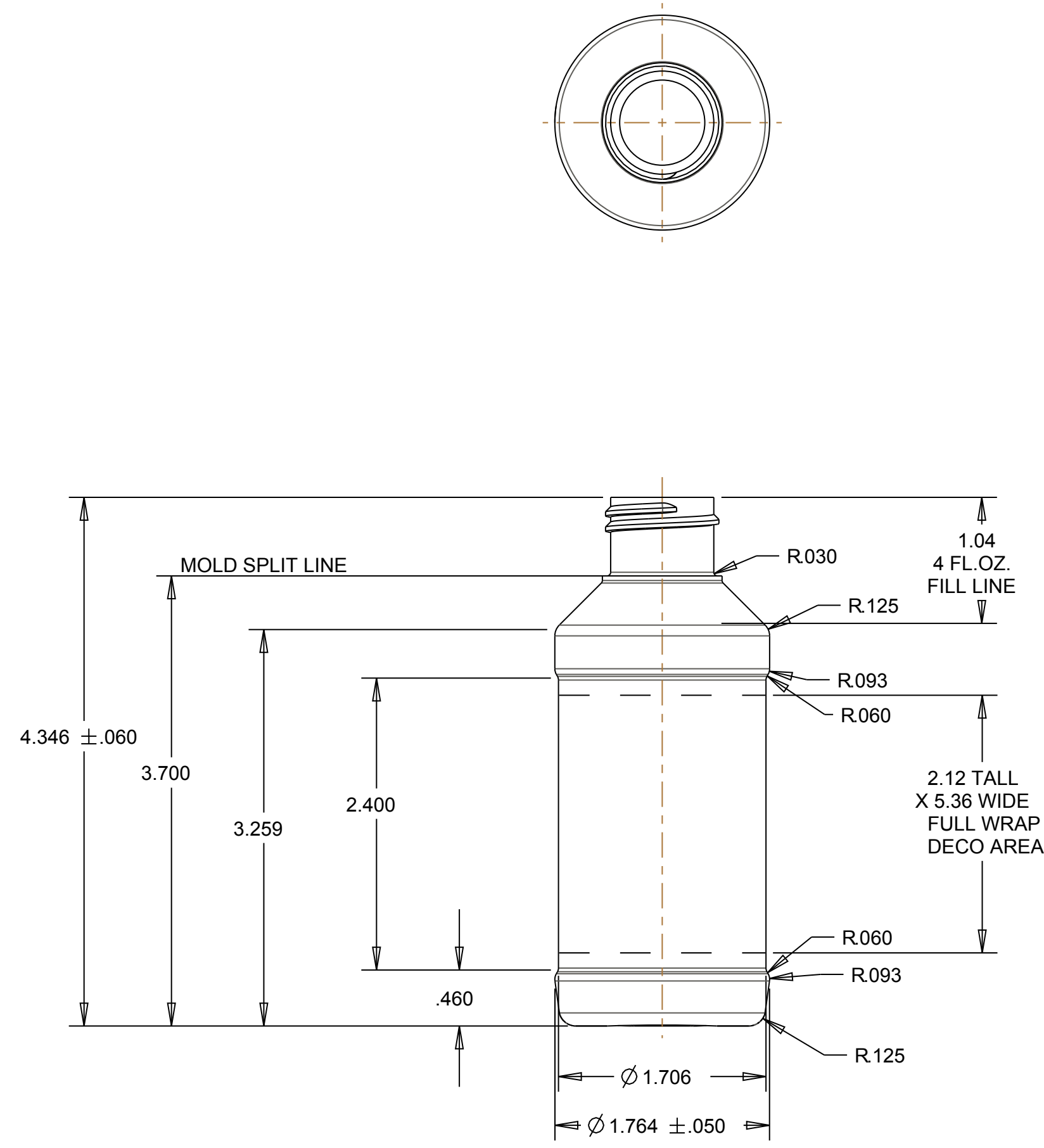
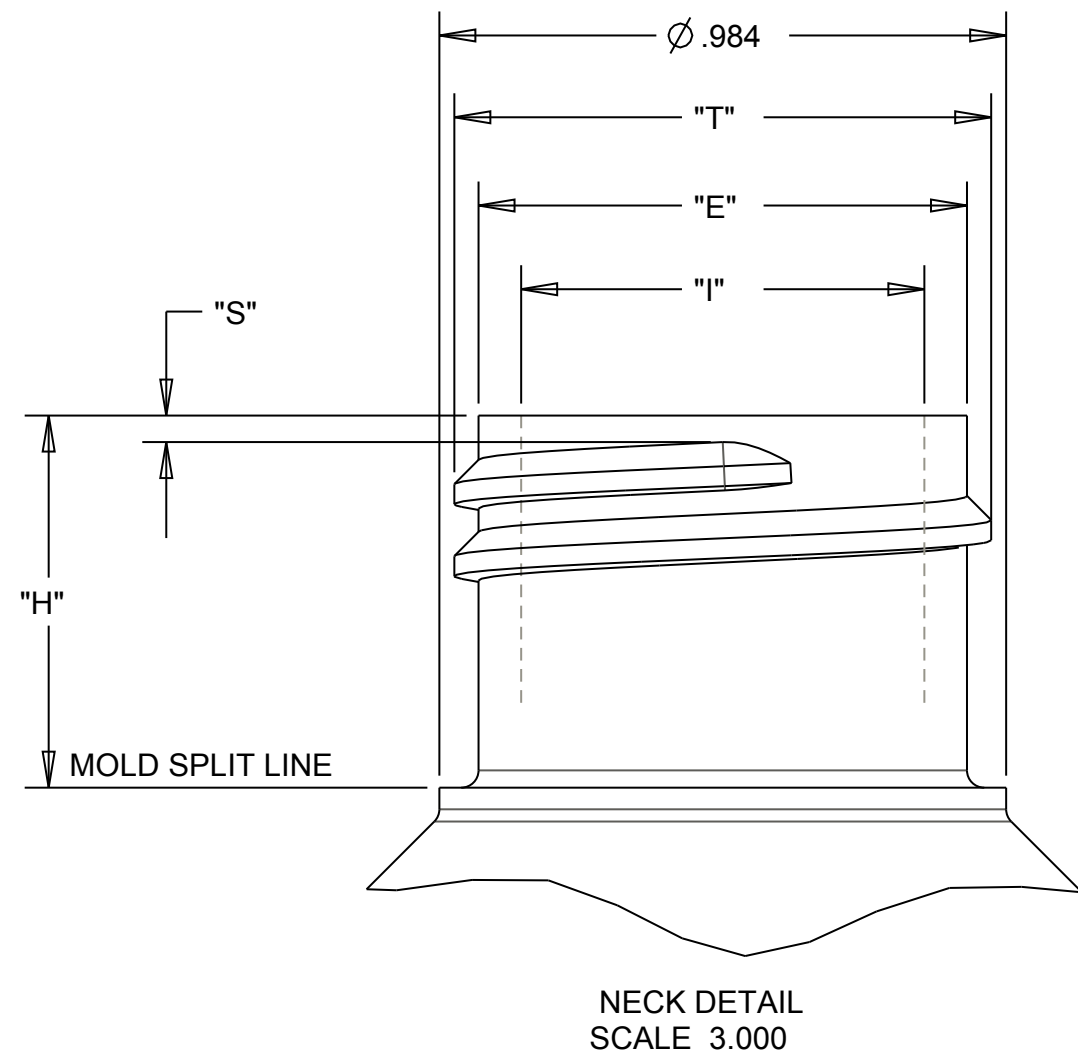

OCEAN STATE PACKAGING EXTRUSION AND INJECTION BLOW MOLDED BOTTLES	
TOL S.P.I.	TITLE 4 OZ MODERN ROUND
DATE 3/28/13	DRAWING NO. SS-1212-OS
	REV A