

NECK FINISH	BOTTLE WEIGHT	OVERFLOW CAPACITY	"T DIA"	"E DIA"	"H DIM"	"I DIA"	"S DIM"
M24SP410	9± 1 GRAMS	66.3± 3.5CC	.940 .924	.856 .840	.661 .631	.516 MIN.	.061 .031

# 2OZ\_CYL\_RD

ENG	DES	DIR	DATE	ISS
KSN			10-Sep-13	1

INITIAL RELEASE

NOTES:

- "M" STYLE THREAD
- 8 THREADS PER INCH
- 1-1/2 FULL TURNS OF THREAD
- MATERIAL - PVC

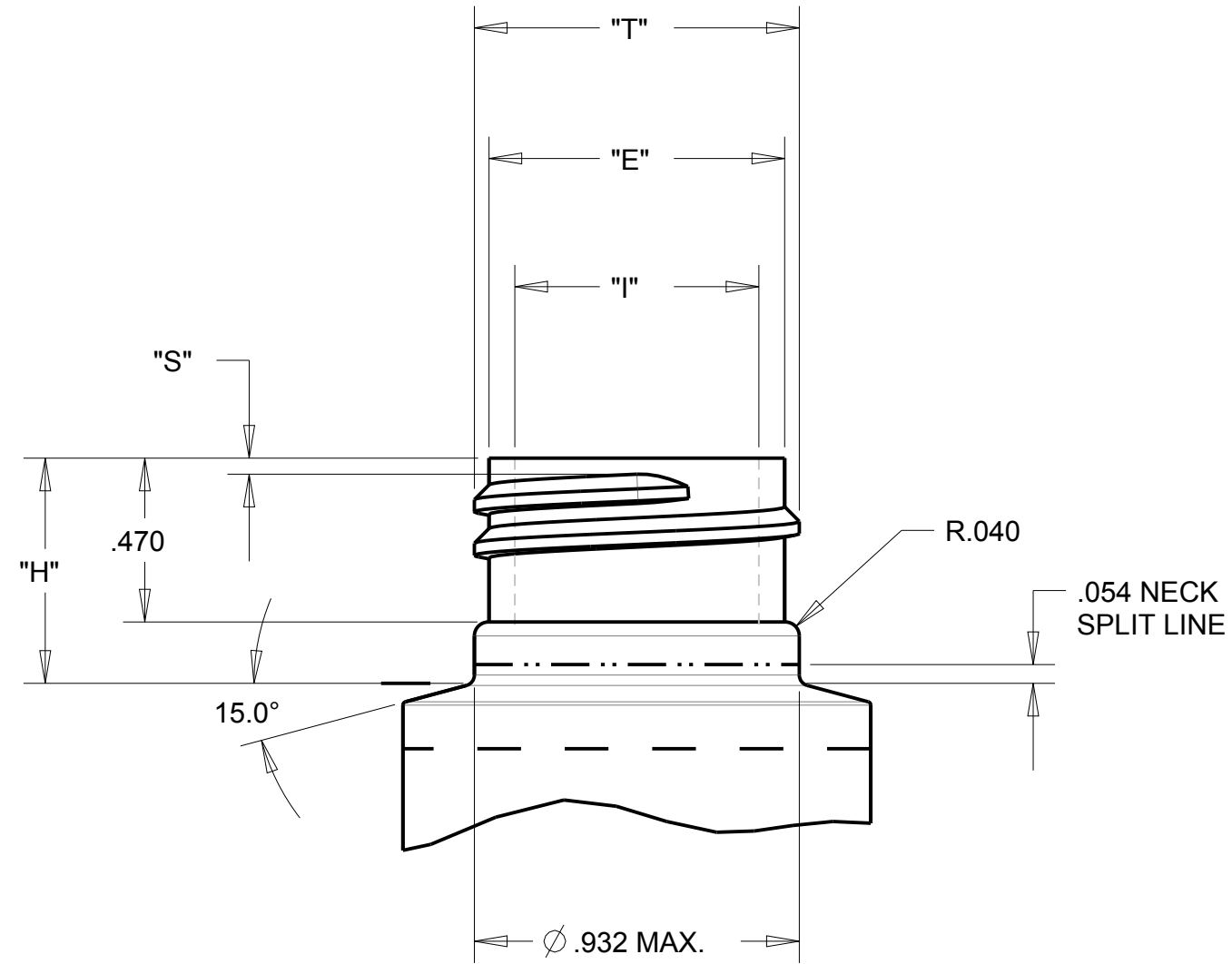
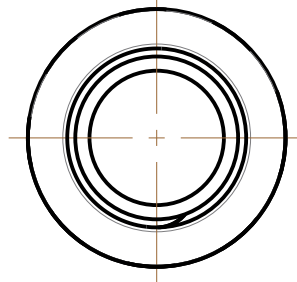

DETAIL A  
SCALE 2.000

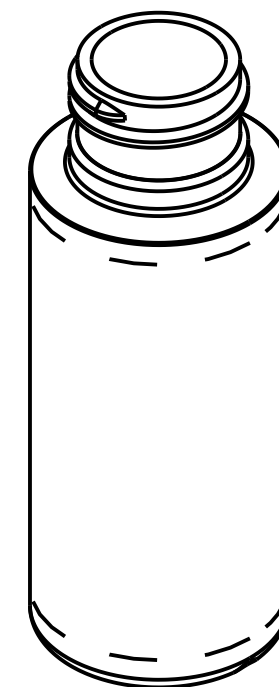
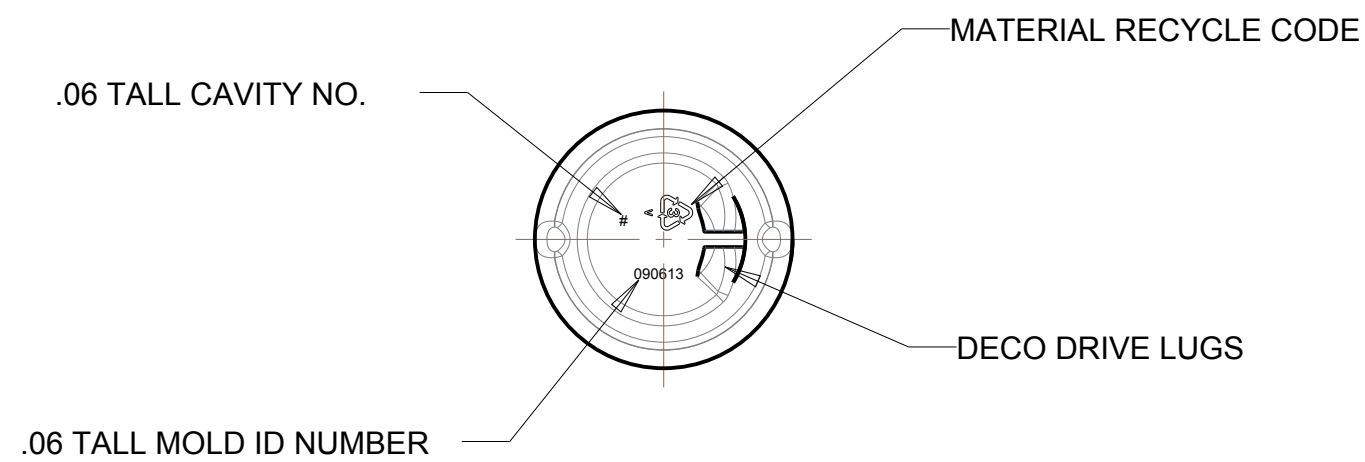
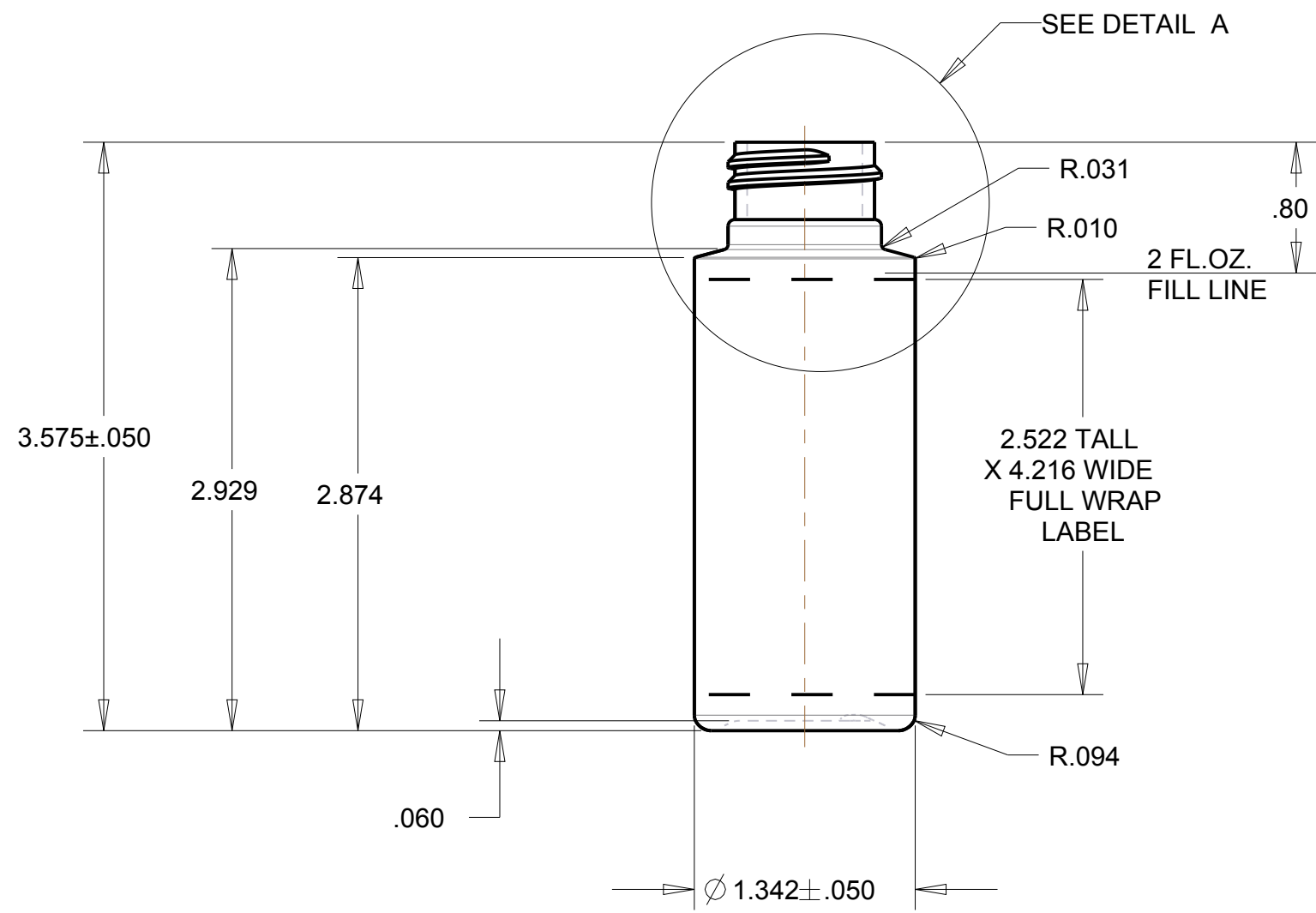

**OCEAN STATE PACKAGING**  
EXTRUSION AND INJECTION BLOW MOLDED BOTTLES

SS-1250-OS

SCALE: 1.000

SHEET: 1 OF 1

# 2OZ\_CYL\_RD