

NECK FINISH	BOTTLE WEIGHT ± 1.5 GRMS	OVERFLOW CAPACITY ± 9 CC	"T" DIA.	"E" DIA.	"H" DIM.	"S" DIM.	"I" DIA.
M24SP400	32.0	390.6 *	.940 .924	.856 .840	.455 .425	.061 .031	.516 MIN.

DATE	SYM	REVISION	BY
8/14/13	A	REMOVED R.015 AT BASE OF NECK	KSN
		CHANGED TITLE	

\*OVERFLOW CAPACITY IS BEFORE DECORATION

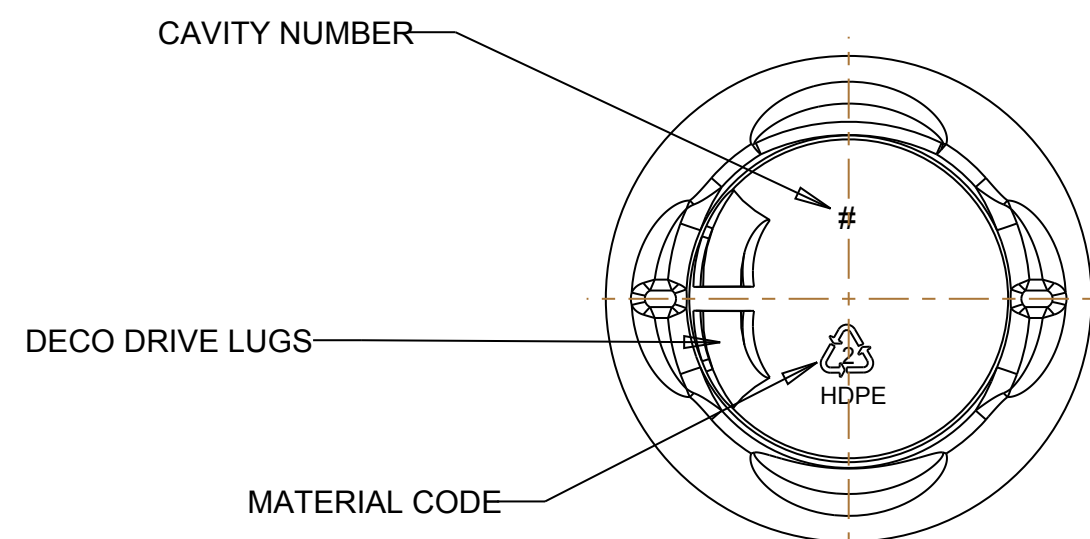
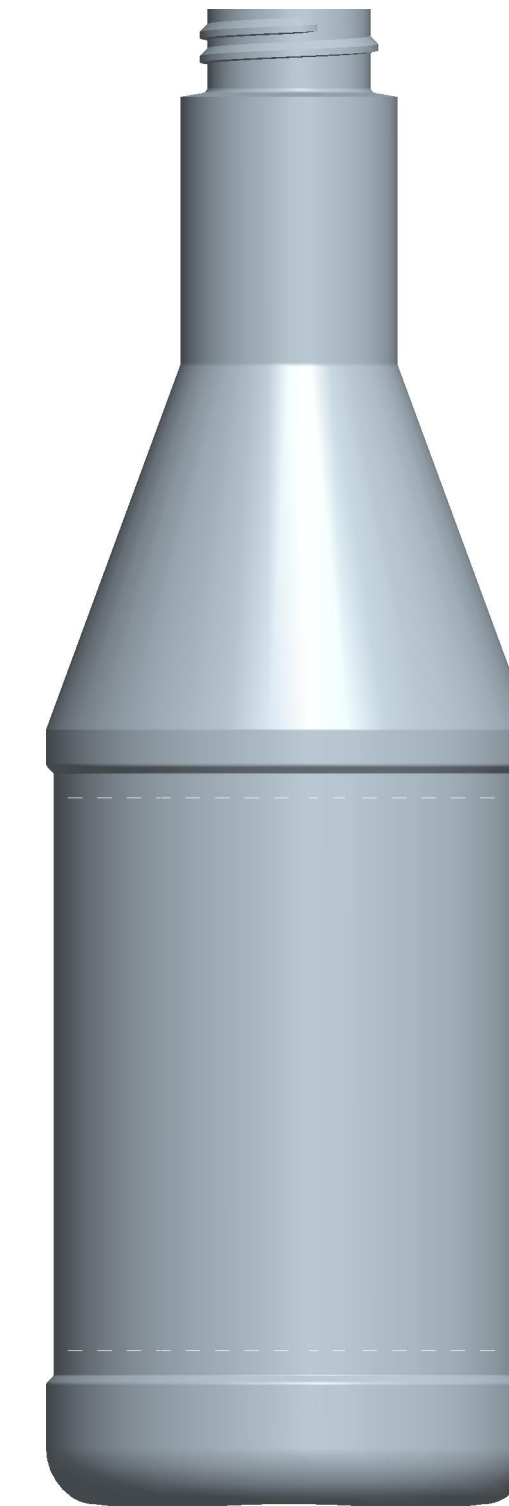
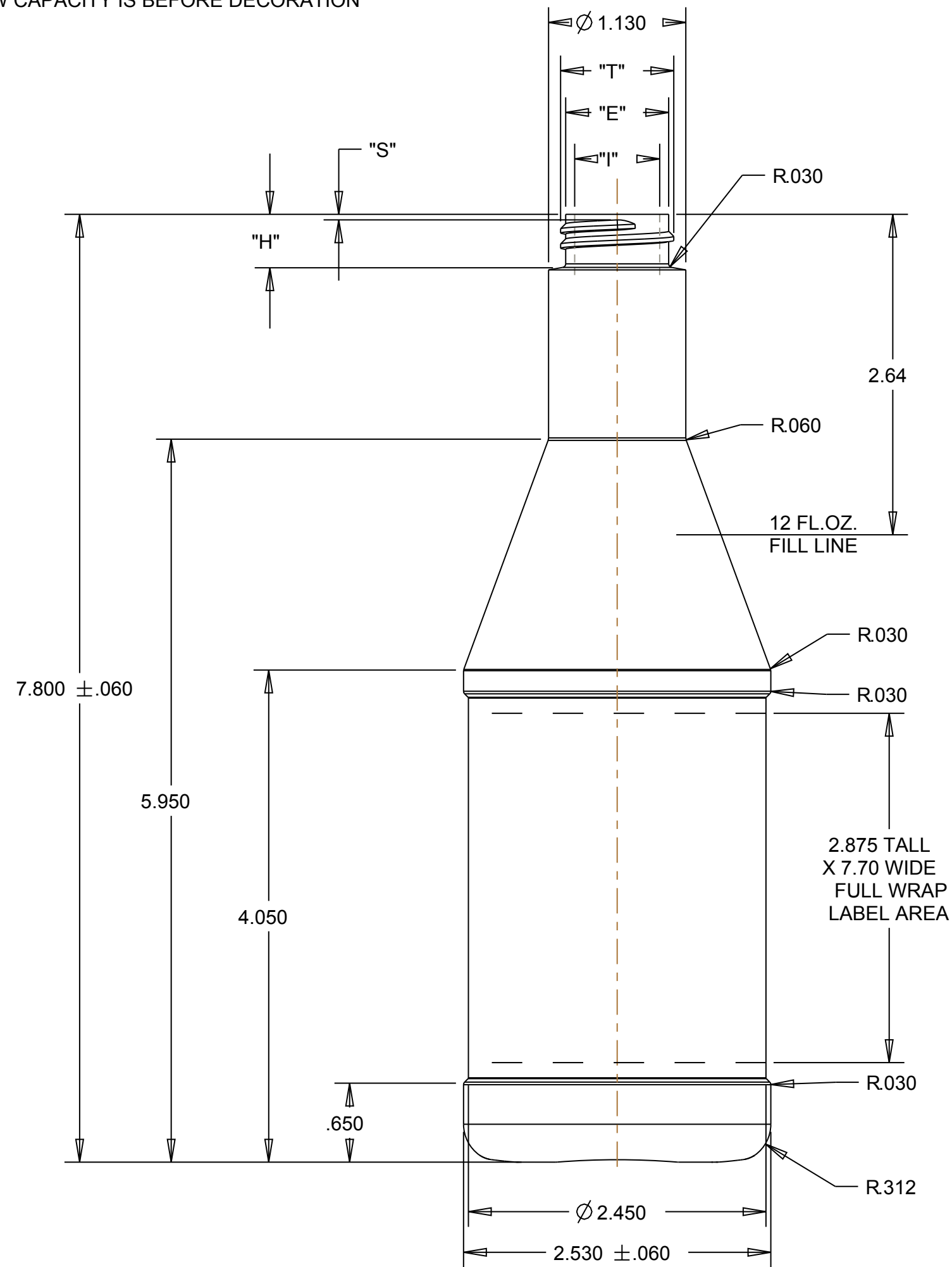

OCEAN STATE PACKAGING EXTRUSION AND INJECTION BLOW MOLDED BOTTLES			
TOL S.P.I.	TITLE 12 OZ POWER STEERING		
DATE 6/22/13	DRAWING NO. SS-1229-OS	REV A	