

DATE	SYM	REVISION RECORD	AUTH	DR	CK

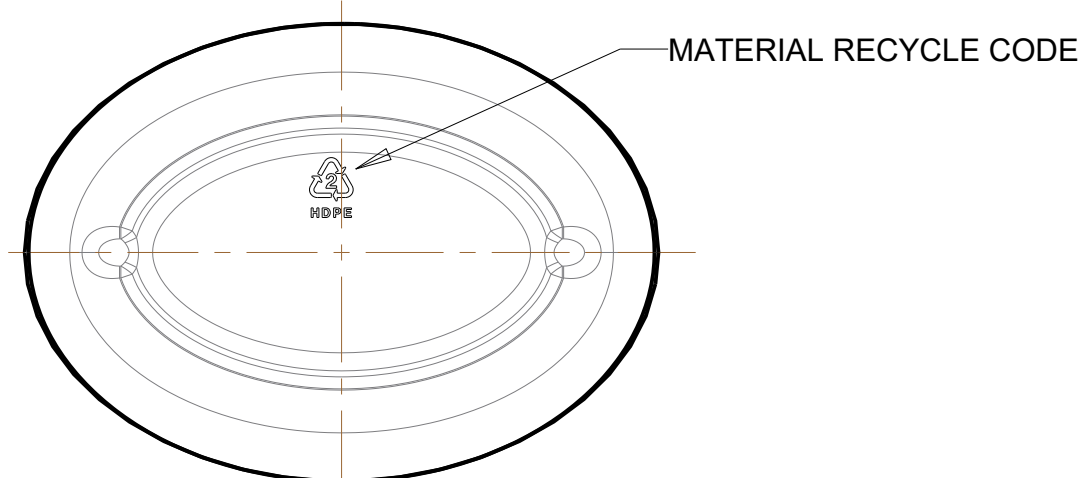
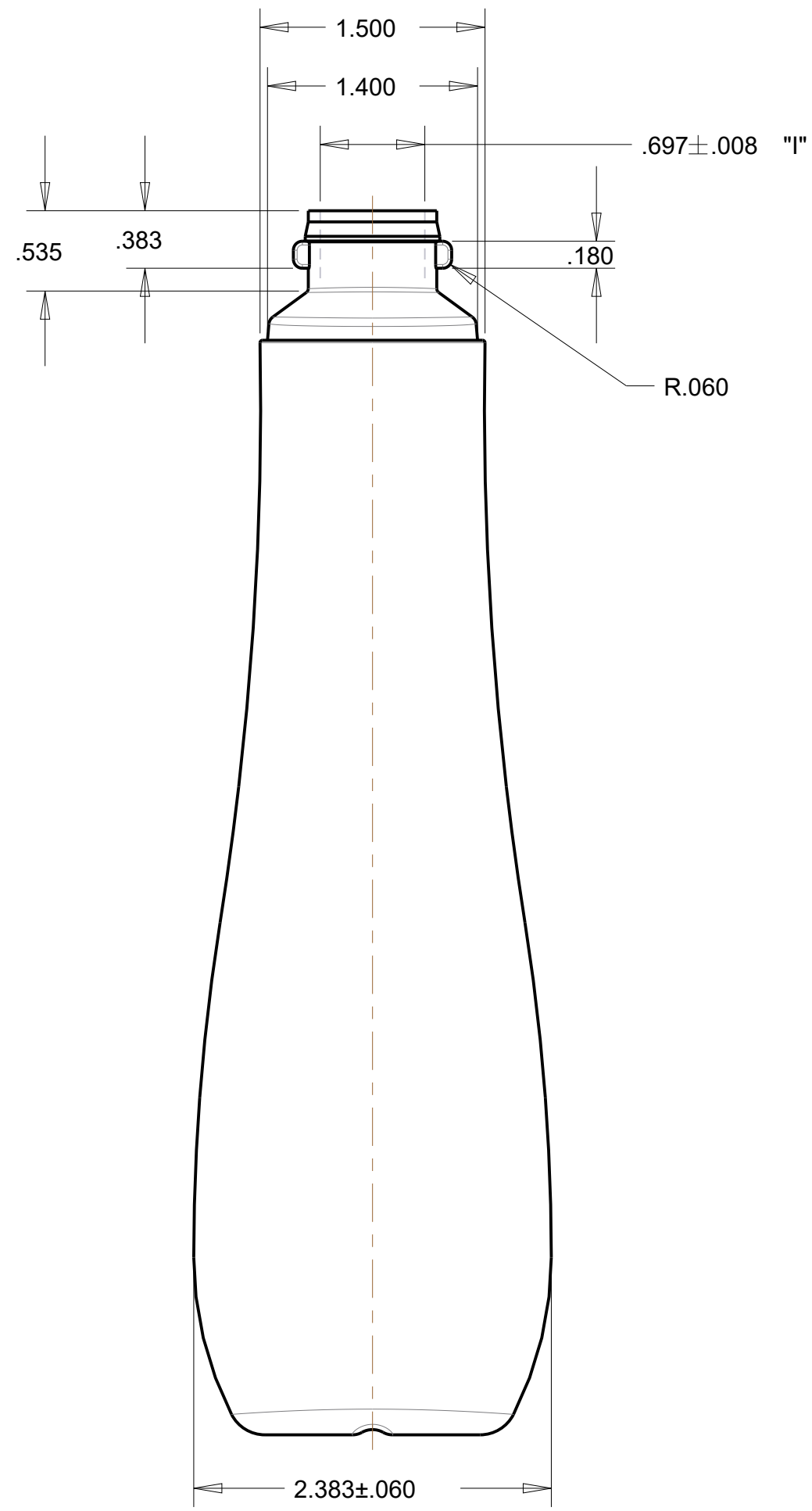
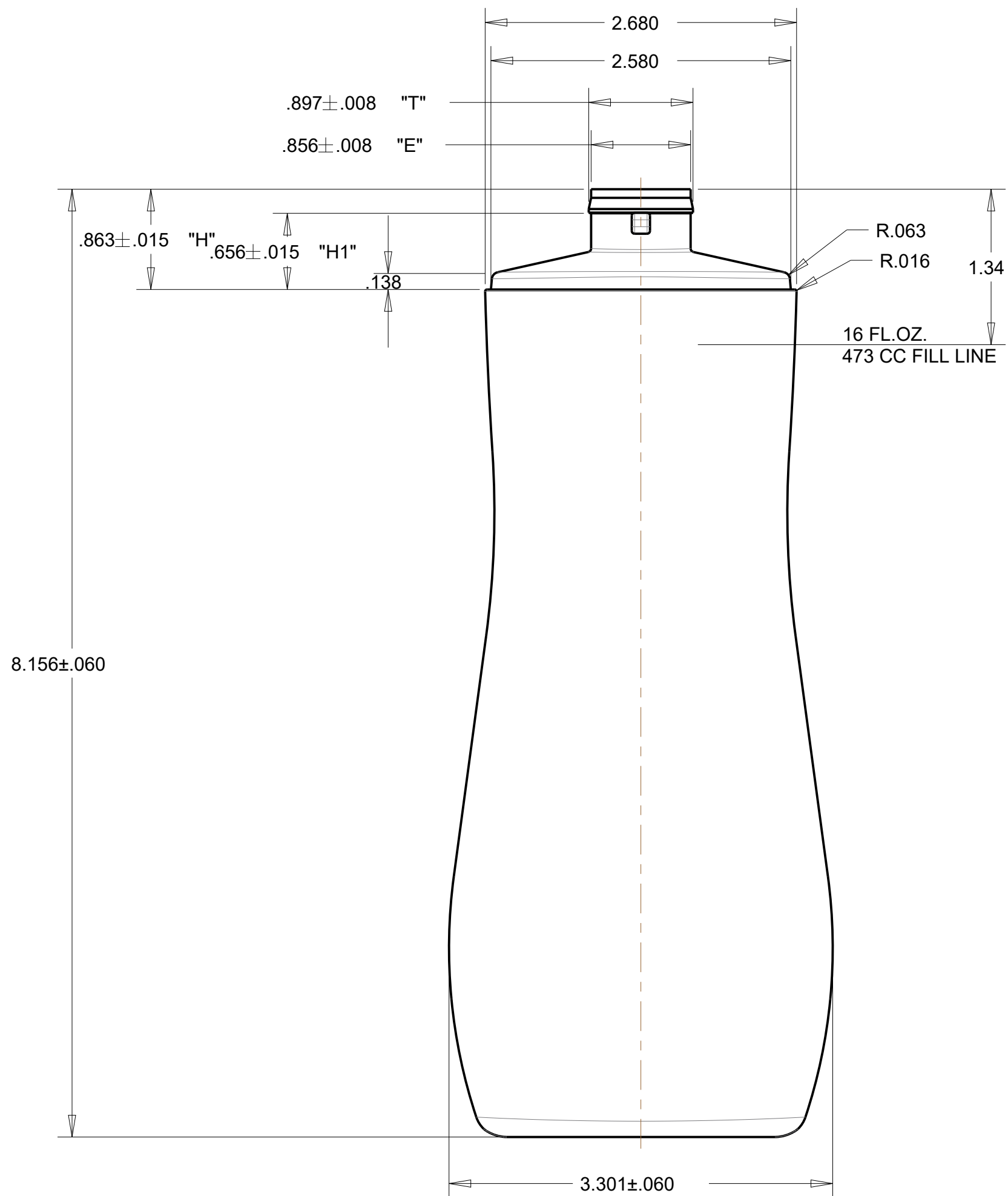
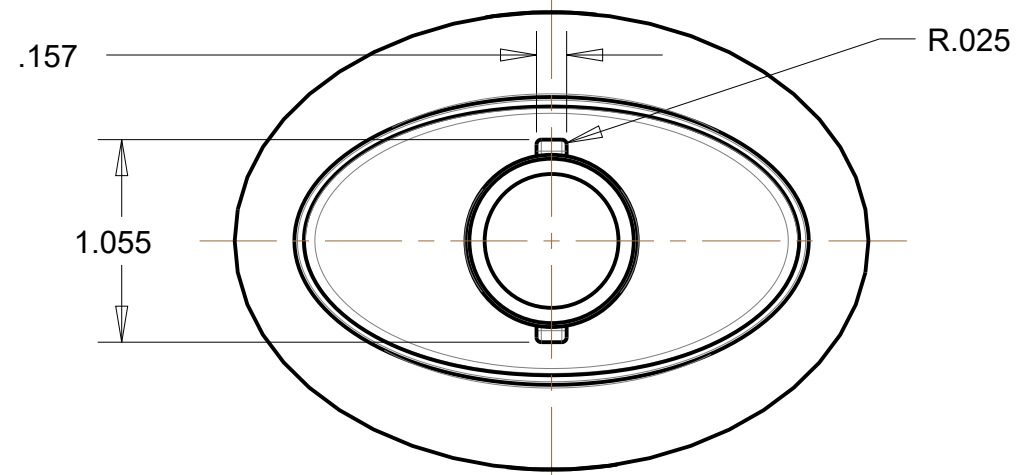

NOTES:

BOTTLE WEIGHT - 34.0 ± 2 GRAMS

OVERFLOW CAPACITY - 505 ± 11 CC

OVERFLOW CAPACITY IS BEFORE DECO

TOLERANCES (EXCEPT AS NOTED)		OCEAN STATE PACKAGING EXTRUSION AND INJECTION BLOW MOLDED BOTTLES			
DECIMAL	MATERIAL HDPE	SCALE FULL	DRAWN BY KSN		MOLD NO
FRACTIONAL	TITLE 16 OZ. OVAL	APPROVED BY			
ANGULAR	DATE 11/3/16	DRAWING NUMBER SS-1383-OS	REVISION		