

NECK FINISH	BOTTLE WEIGHT ±2 GRAMS	OVERFLOW CAPACITY ±15 CC	"T" DIA.	"E" DIA.	"H" DIM.	"S" DIM.	"I" DIA.
53-400	45.0	818.0	2.067 2.032	1.973 1.938	.435 .405	.061 .031	1.578 MIN.

DATE	SYM	REVISION	BY

NOTES:

- ONE FULL TURN OF THREAD
- OVERFLOW CAPACITY IS BEFORE DECO.
- 6 THREADS PER INCH PITCH

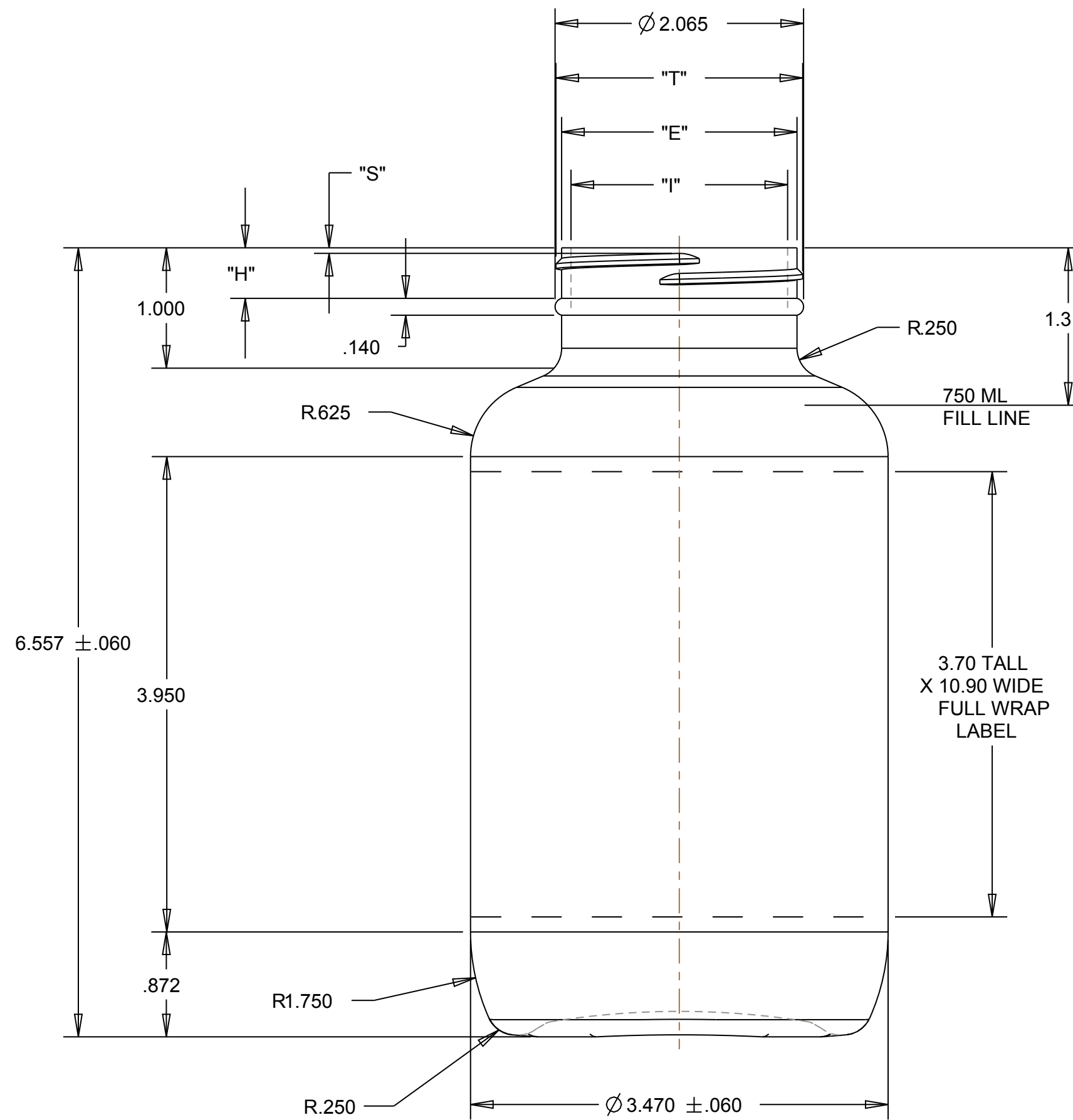
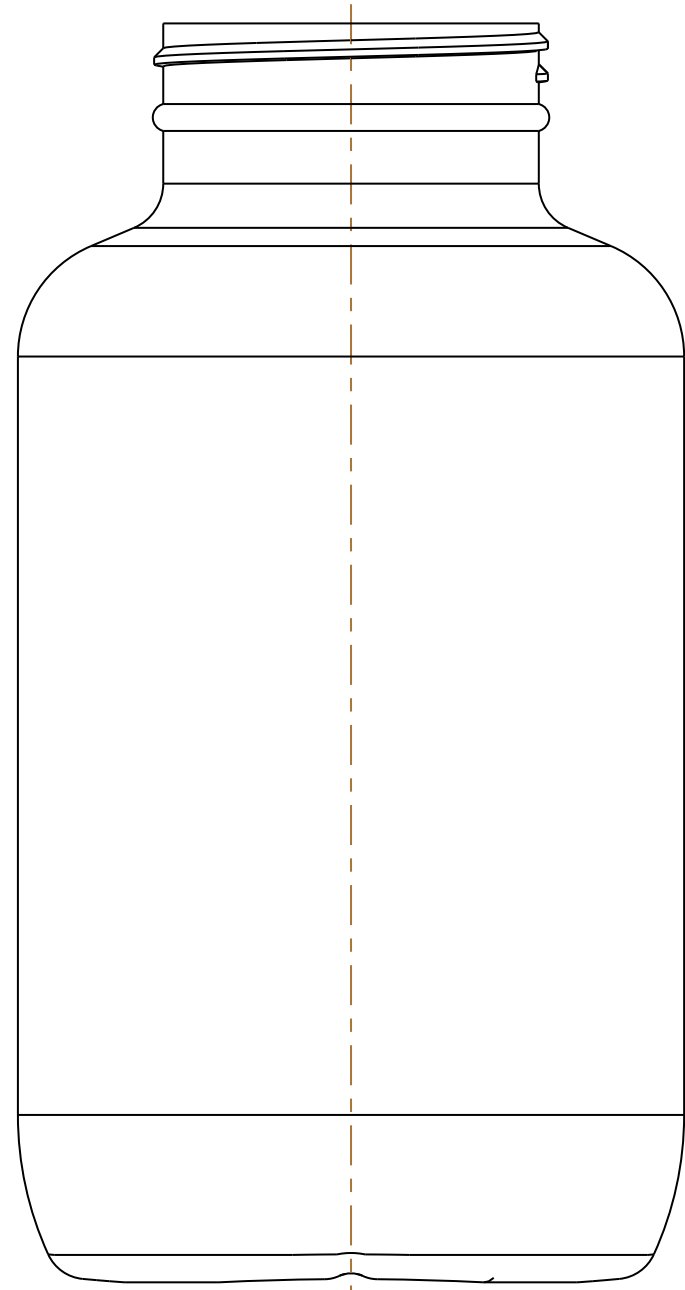

MATERIAL RECYCLE CODE

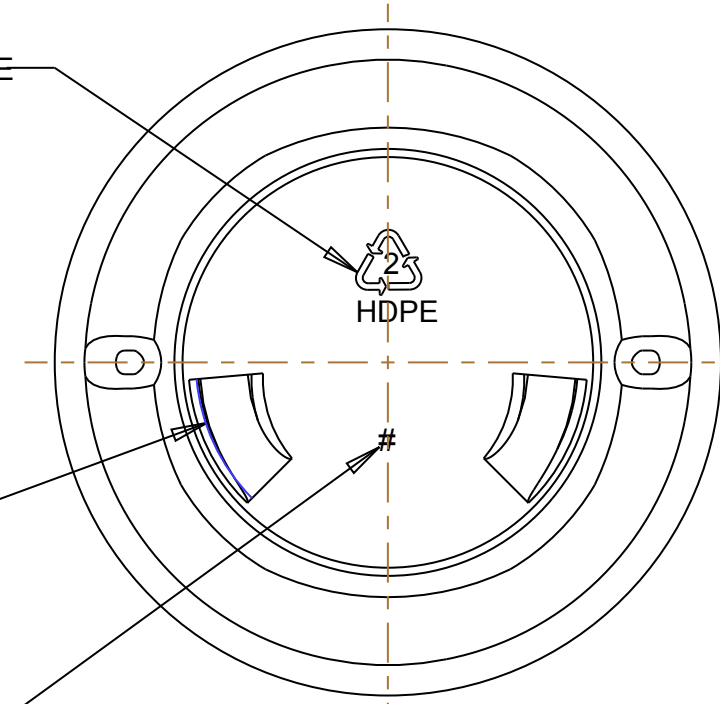

DECO DRIVE LUGS

CAVITY NO.'S

OCEAN STATE PACKAGING EXTRUSION AND INJECTION BLOW MOLDED BOTTLES	
TOL S.P.I.	TITLE 750 ML PACKER
DATE 6/8/13	DRAWING NO. SS-1225-OS
	REV