

NOTES:
 MATERIAL: HDPE
 SUGGESTED SOURCE: EQUISTAR 5602 (WITH 25% PCR ADDED)
 COLOR: WHITE TO MATCH COLOR CHIP SUPPLIED BY THETFORD CORPORATION.
 SEALING SURFACE OF BOTTLE NECK MUST BE SMOOTH AND FREE OF BURRS AND IRREGULARITIES AND FLAT WITHIN .010 T.I.R. WITH RESPECT TO A PLANE PERPENDICULAR TO THE THREADED AXIS.
 ANY NONFLATNESS MUST BE GRADUAL AT A RATE NOT TO EXCEED .001 PER 3" ARC LENGTH ALONG THE SEALING SURFACE

.015 ABSOLUTE MINIMUM WALL THICKNESS.
 REF. P/D # 28575

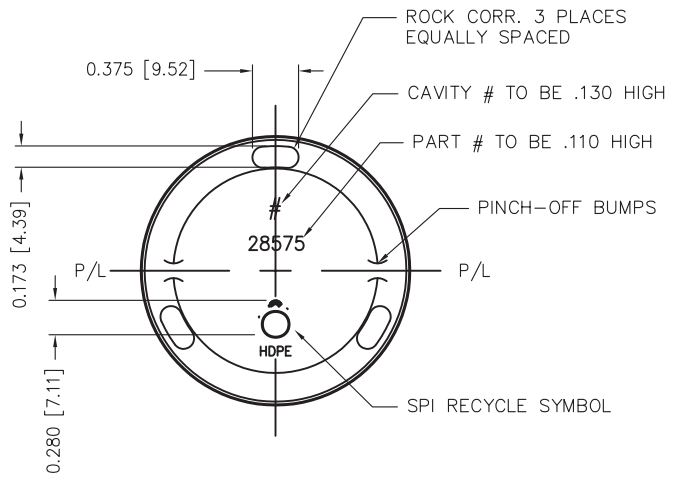

NO.	REV.	BY	DESCRIPTION	DATE	
NECK FINISH: M28 SP400 (SPECIAL) GRAM WT. 19.0 ±1g					
'T'	'E'	'H'	'S'	'L'	'W'
1.078 ±.010	.987 ±.007	.490 ±.015	.046 ±.015	.500 ±.015	_____
27.38 ±0.25	25.07 ±0.18	12.45 ±0.38	1.17 ±0.38	12.70 ±0.38	_____
HELIX <: 2' 57'		T.P.I.: 6	CUTT. DIA.: .500[12.70]		
CAPACITY TO FILL LEVEL BEFORE DECORATING				236.50 ±7ml	
CAPACITY TO FILL LEVEL AFTER DECORATING				_____	
OVERFLOW CAPACITY BEFORE DECORATING				267.0 ±7ml	
OVERFLOW CAPACITY AFTER DECORATING				_____	

DRAWING CHECKED SPECIFICALLY FOR:
 NECK FINISH
 WEIGHT
 CAPACITY
 MATERIAL
 SPECIAL REQUESTS
 PRODUCT DESIGN TO BE APPROVED BEFORE MOLD CAVITIES ARE MACHINED.
 APPROVED BY
 DATE

DRAWN BY: 255	DESC. 8 oz. MODERN ROUND
SCALE: 1:1	DATE: DEC 22/05
BOTTLE MAT'L: HDPE	DRAWING NO. 12-30758-PD
CAD NAME: PD\12-30758-PD	MOULD NO. 12-30758-3

TEMPORARY DRAWING
 THIS IS A SUGGESTED DESIGN FOR CUSTOMER APPROVAL.
 FINAL SIZES AND SPECIFICATIONS ARE SUBJECT TO
 FINAL PRODUCTION QUALIFICATIONS.