

LUG DETAIL
SCALE: 2-1

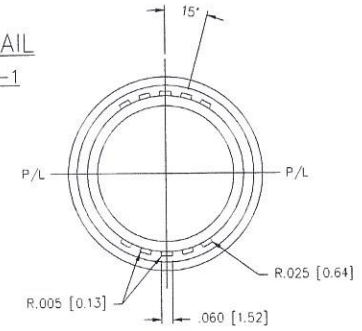

| | | | |
|----|-----|-------------------------------------|------------|
| F4 | CDL | REF. HT. WAS 7.508" | FEB.21/06 |
| F3 | CDL | 'H' WAS .470" | FEB.21/06 |
| F2 | CDL | 'S' WAS .046" | FEB.21/06 |
| F1 | CDL | 28mm SPECIAL NECK ADDED | FEB.21/06 |
| E3 | CDL | LABEL WIDTH WAS 9.132" | JULY.27/05 |
| E2 | CDL | DIAMETER WAS 2.990" | JULY.27/05 |
| E1 | CDL | GRAM WT. WAS 41±2.5 | JULY.27/05 |
| D5 | CDL | WRAP AROUND LABEL WAS 8.900" | JULY21/05 |
| D4 | CDL | F/L ADJUSTED FOR INCREASED OVERFLOW | JULY21/05 |
| D3 | CDL | RADIUS WAS 1.671 | JULY21/05 |
| D2 | CDL | DIA. WAS 2.912 | JULY21/05 |
| D1 | CDL | O/F/C WAS 675ml±13 | JULY21/05 |
| C1 | CDL | LABEL AREA ADDED | MAY.19/05 |
| B4 | CDL | OFC WAS 670ml | MAY.4/05 |
| B3 | CDL | DIA WAS 3.144 | MAY.4/05 |
| B2 | CDL | SHOULDER REVISED | MAY.4/05 |
| B1 | CDL | REF. HT. WAS 7.258 | MAY.4/05 |
| A3 | CDL | DIAMETER WAS 3.180" | APR.25/05 |
| A2 | CDL | O/F/C WAS 663ml | APR.25/05 |
| A1 | CDL | SHOULDER REVISED | APR.25/05 |

| NO. | REV. | BY | DESCRIPTION | DATE | |
|---------------|--------------|--------------|-------------------|----------------------|-------------|
| NECK FINISH: | | | M28 SP400 SPECIAL | GRAM WT. 45±2.5 (E1) | |
| 'T' | 'E' | 'H' | 'S' | 'L' | 'W' |
| 1.078 ± 0.010 | .984 ± 0.010 | 445 ± 0.015 | .065 ± 0.015 | | |
| 27.38 ± 0.25 | 24.99 ± 0.25 | 11.30 ± 0.38 | 1.65 ± 0.38 | | |
| HELIX <: | 2' 57" | T.P.I.: | 6 | CUTT. DIA.: | 500 [12.70] |

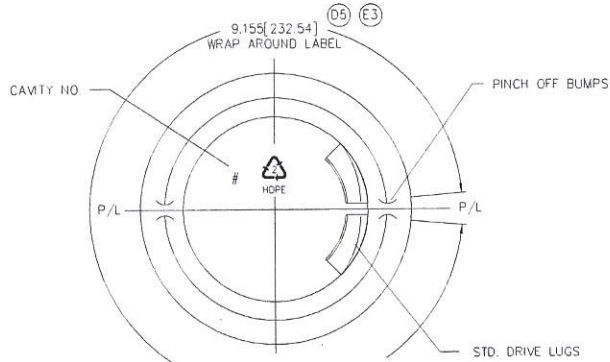

TEMPORARY DRAWING-NOT RELEASED FOR PRODUCTION
THIS IS A SUGGESTED DESIGN FOR CUSTOMER APPROVAL.
FINAL SIZES AND VOLUME ARE SUBJECT TO MouldING
SPECIFICATIONS AND PRODUCTION QUALIFICATIONS.

DRAWING CHECKED SPECIFICALLY FOR:
NECK FINISH
WEIGHT
CAPACITY
MATERIAL
SPECIAL REQUESTS
PRODUCT DESIGN TO BE APPROVED BEFORE Mould CAVITIES ARE MACHINED.
APPROVED BY
DATE

| | | |
|--|----------------|-------------------------------|
| CAPACITY TO FILL LEVEL BEFORE DECORATING | | 664ml ±13 |
| CAPACITY TO FILL LEVEL AFTER DECORATING | | |
| OVERFLOW CAPACITY BEFORE DECORATING | | 713ml ±13 (A2) (D1) |
| OVERFLOW CAPACITY AFTER DECORATING | | |
| r | | |
| DRAWN BY: | DS | DESC. 22oz. SOFT SHOULDER RD. |
| SCALE: | 1-1 | DATE: APR.13/05 |
| BOTTLE MAT'L: | HDPE | DRAWING NO. 3-6690-PF |
| CAD NAME: | PD\6XXX\3-6690 | MOULD NO. 3-30090-3 |