

NECK FINISH	BOTTLE WEIGHT ±1.5 GRAMS	OVERFLOW CAPACITY ±6 CC	"T" DIA.	"E" DIA.	"H" DIM.	"S" DIM.	"I" DIA.
28-400	17.0	200.5	1.088 1.068	.994 .974	.415 .385	.061 .031	.614 MIN.

DATE	SYM	REVISION	BY
5/7/13	A	ADDED 1.505 DIM ADDED 1.338 DIM	KSN

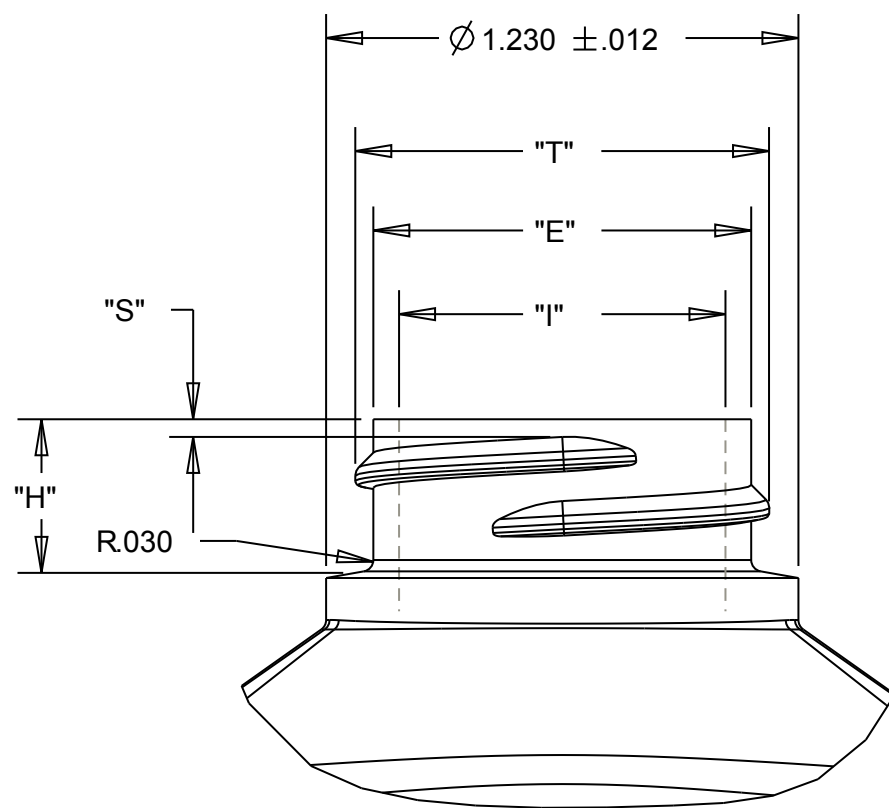

DETAIL A  
SCALE 2.000

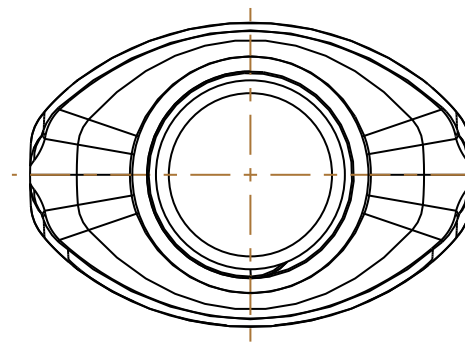
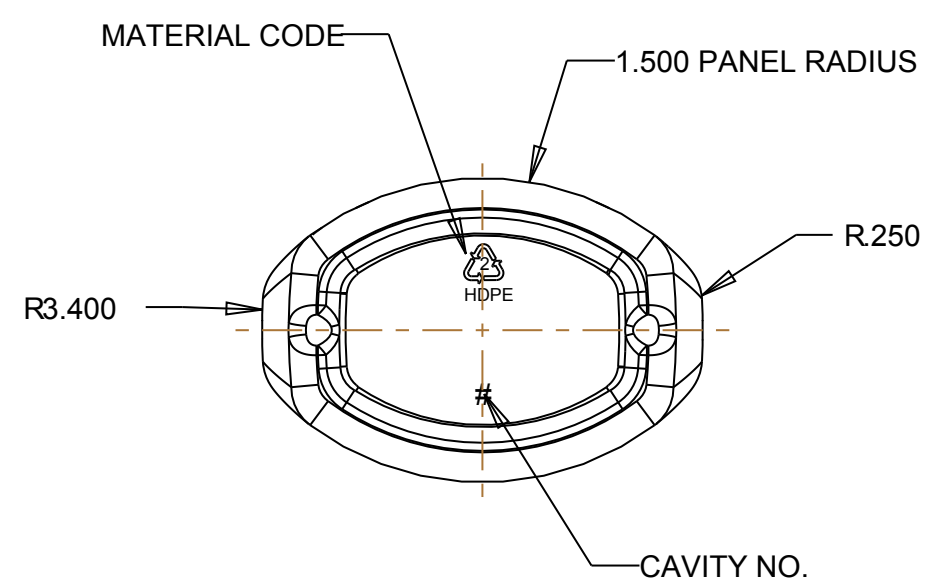
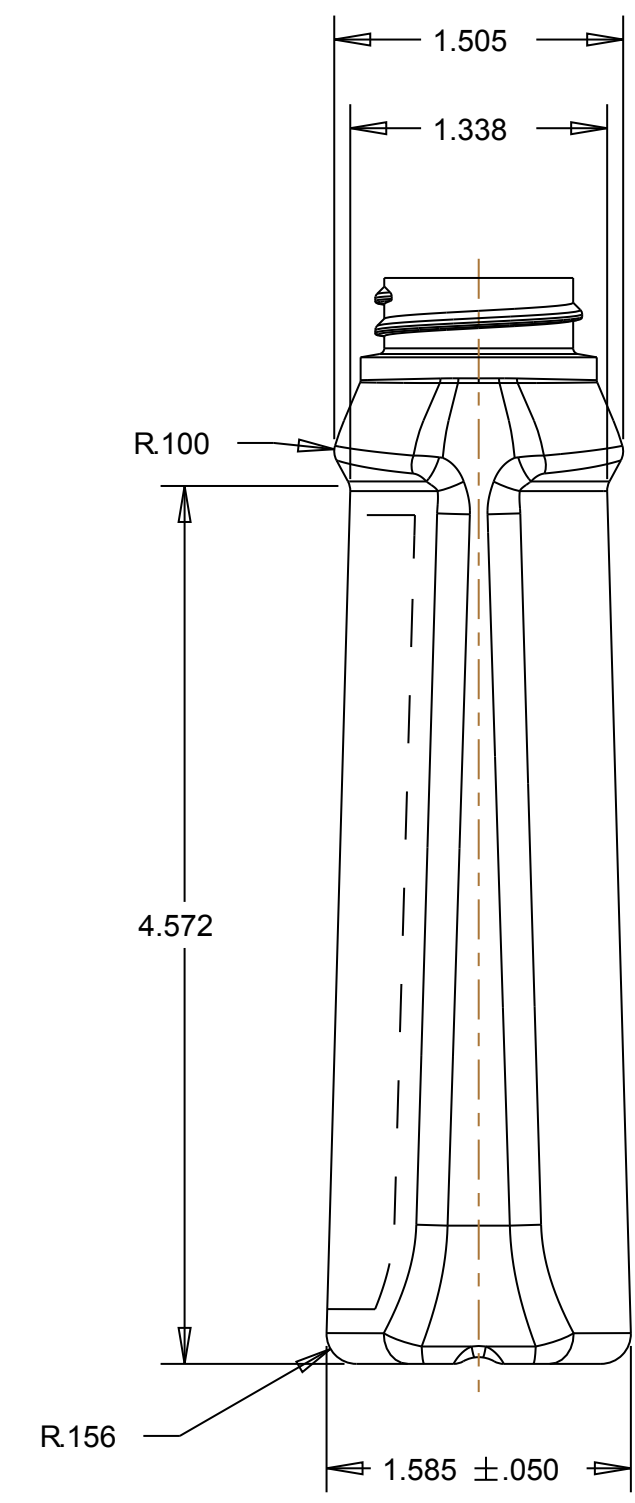
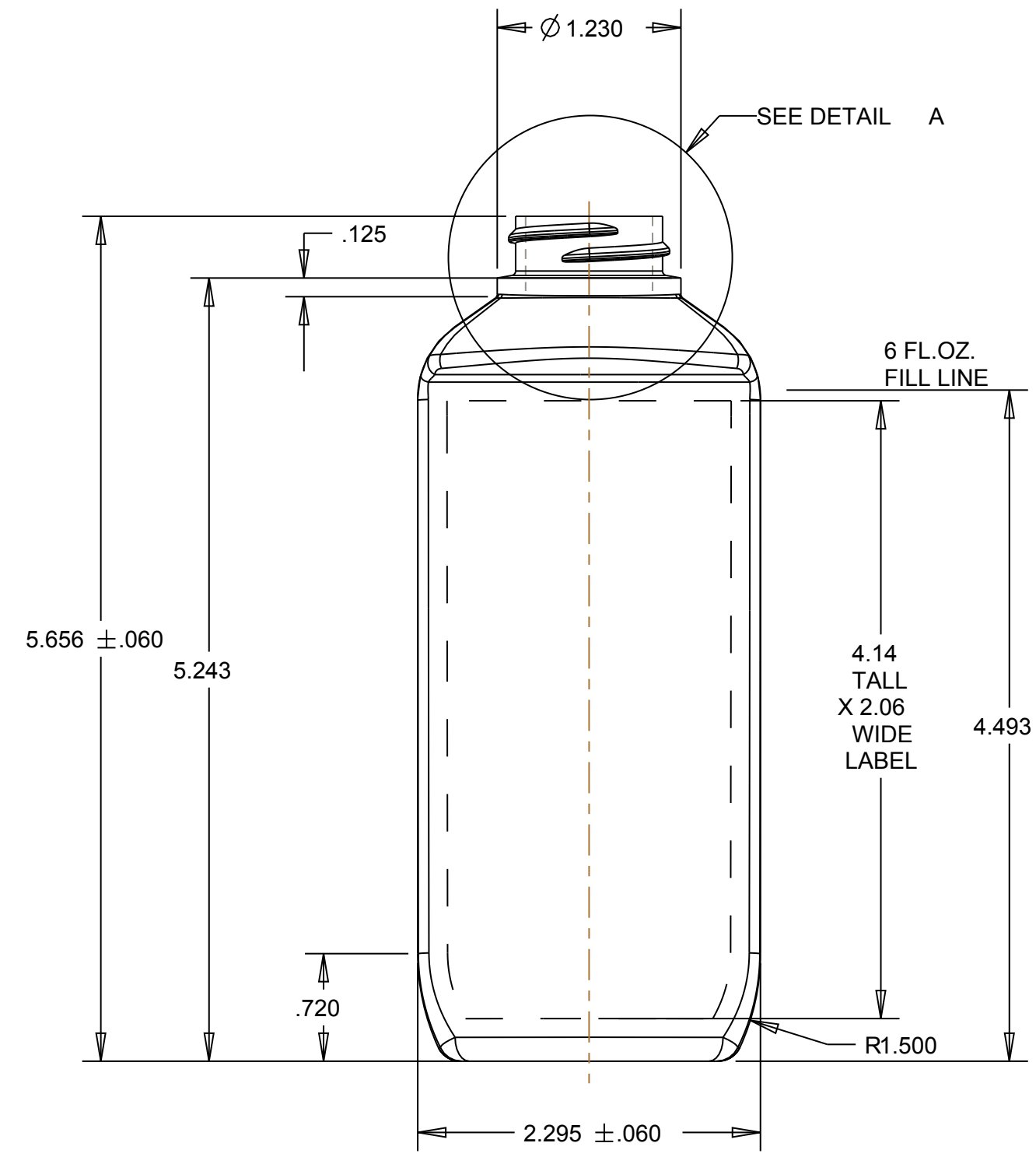

<b>OCEAN STATE PACKAGING</b> EXTRUSION AND INJECTION BLOW MOLDED BOTTLES			
TOL	TITLE		
S.P.I.	6 OZ ANTACID OBLONG		
DATE	DRAWING NO.	REV	
5/3/13	SS-1217-OS	A	