

NECK FINISH	BOTTLE WEIGHT ±2 GRAMS	OVERFLOW CAPACITY ±9 CC	"T" DIA.	"E" DIA.	"H" DIM.	"S" DIM.	"I" DIA.
33 MM HOFFER	34.0	381.7	1.264 1.240	1.157 1.133	.745 .715	.065 .035	.791 MIN.

DATE	SYM	REVISION	BY

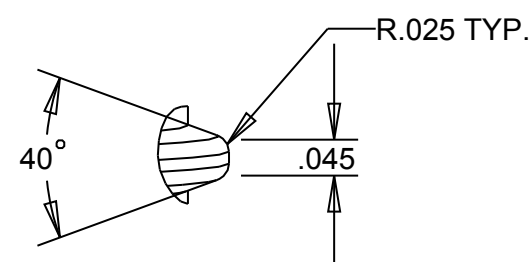

DETAIL B
SCALE 4.000

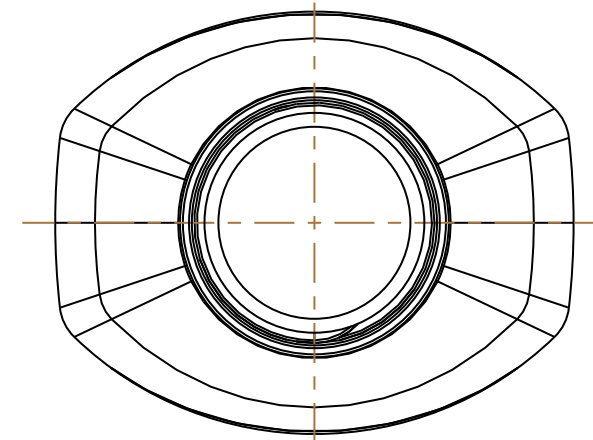
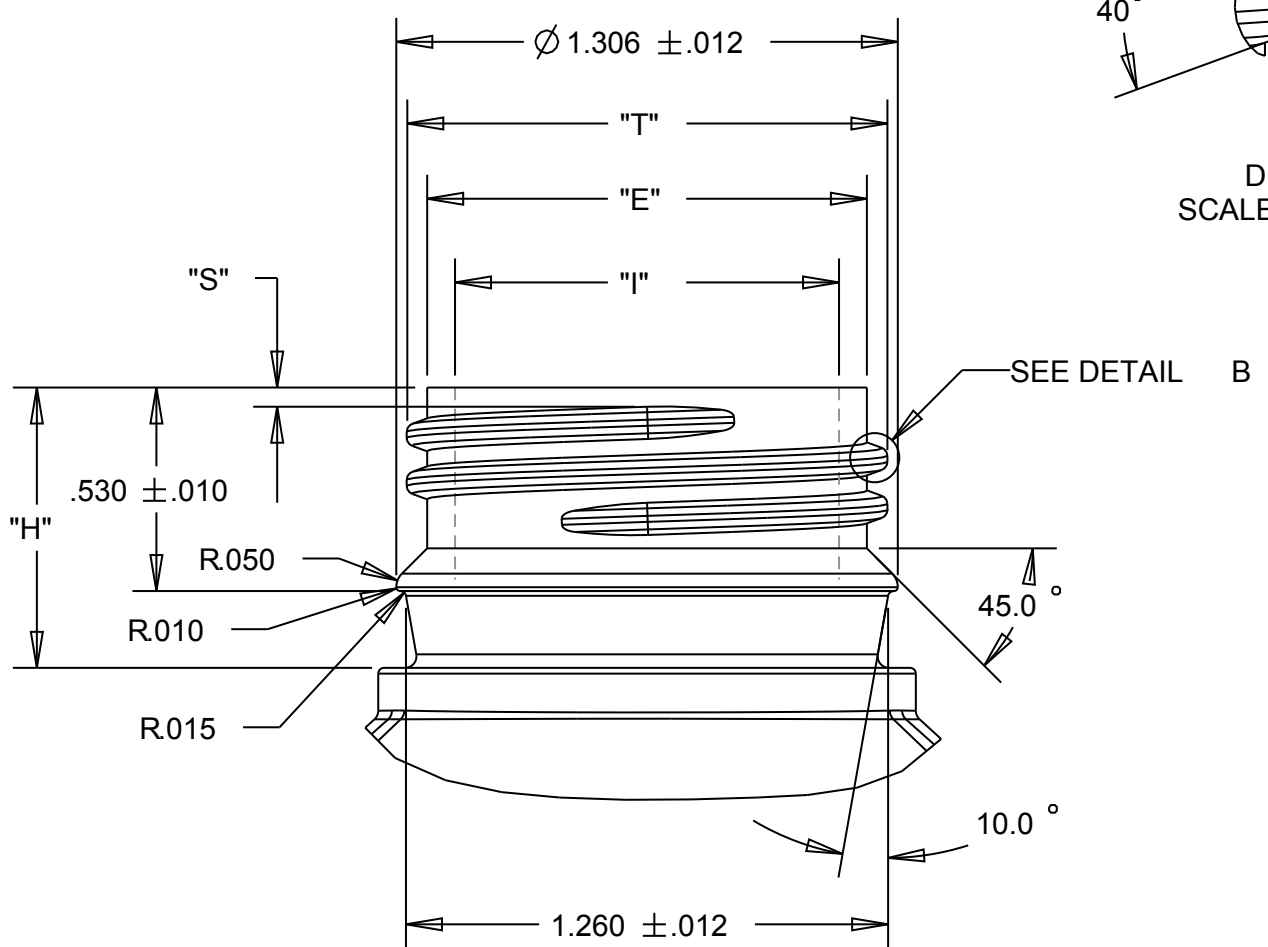

8 THREADS PER INCH
2 FULL TURNS OF THREAD

DETAIL A
SCALE 2.000

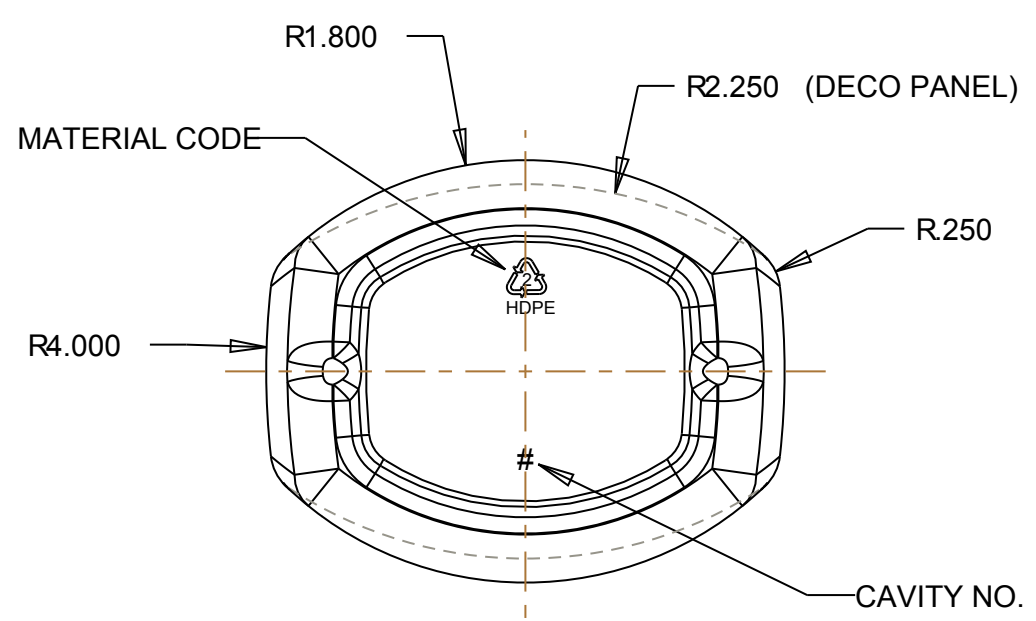
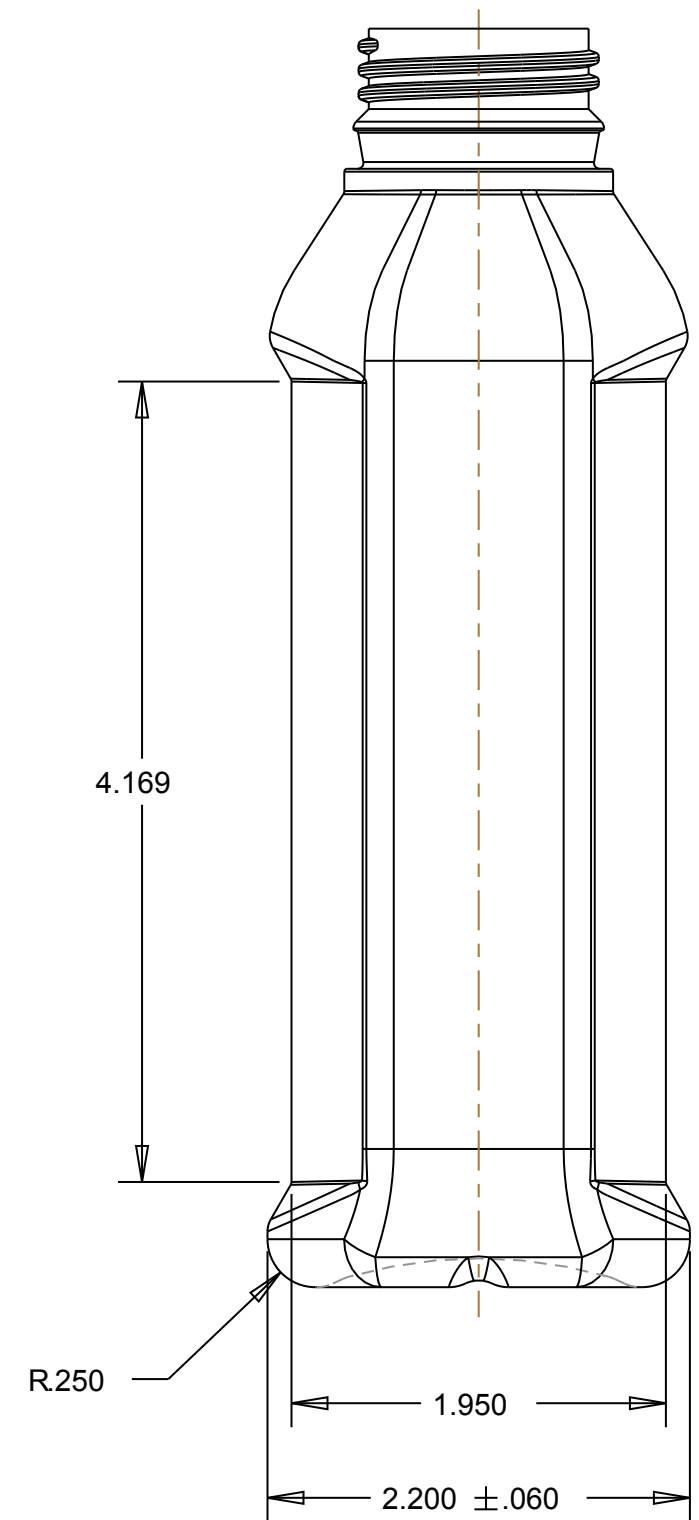
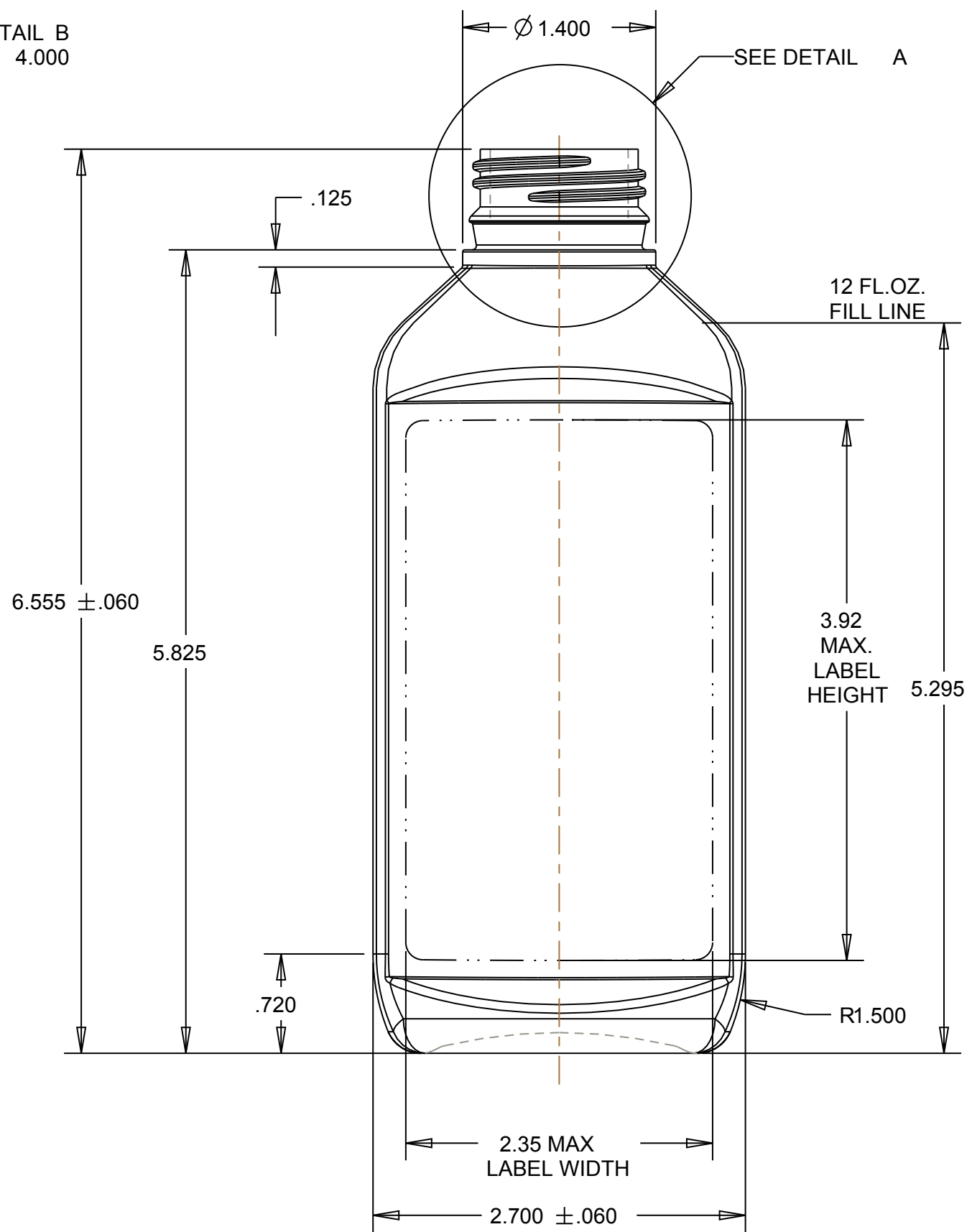

OCEAN STATE PACKAGING EXTRUSION AND INJECTION BLOW MOLDED BOTTLES			
TOL	TITLE		
S.P.I.	12 OZ ANTACID OBLONG		
DATE	DRAWING NO.	REV	
5/21/12	SS-1186-OS		