

NECK FINISH	BOTTLE WEIGHT (± 3.5 GR)	OVERFLOW CAPACITY (± 20 CC)	"T" DIA	"E" DIA	"H" DIM	"S" DIM	"I" DIA	MATERIAL
33-400	65.0	1166.0	1.265 1.241	1.171 1.147	.432 .402	.061 .031	.791 MIN	HDPE

DATE	SYM	REVISION RECORD	AUTH	DR	CK

NOTES:

- 33-400 NECK FINISH
- 6 THREADS PER INCH
- .167 PITCH
- "M" STYLE THREAD
- ONE FULL TURNS OF THREAD
- OVERFLOW CAPACITY SHOWN IS BEFORE DECO.
- OVERFLOW CAPACITY INCLUDES 10 CC OF BULGE.

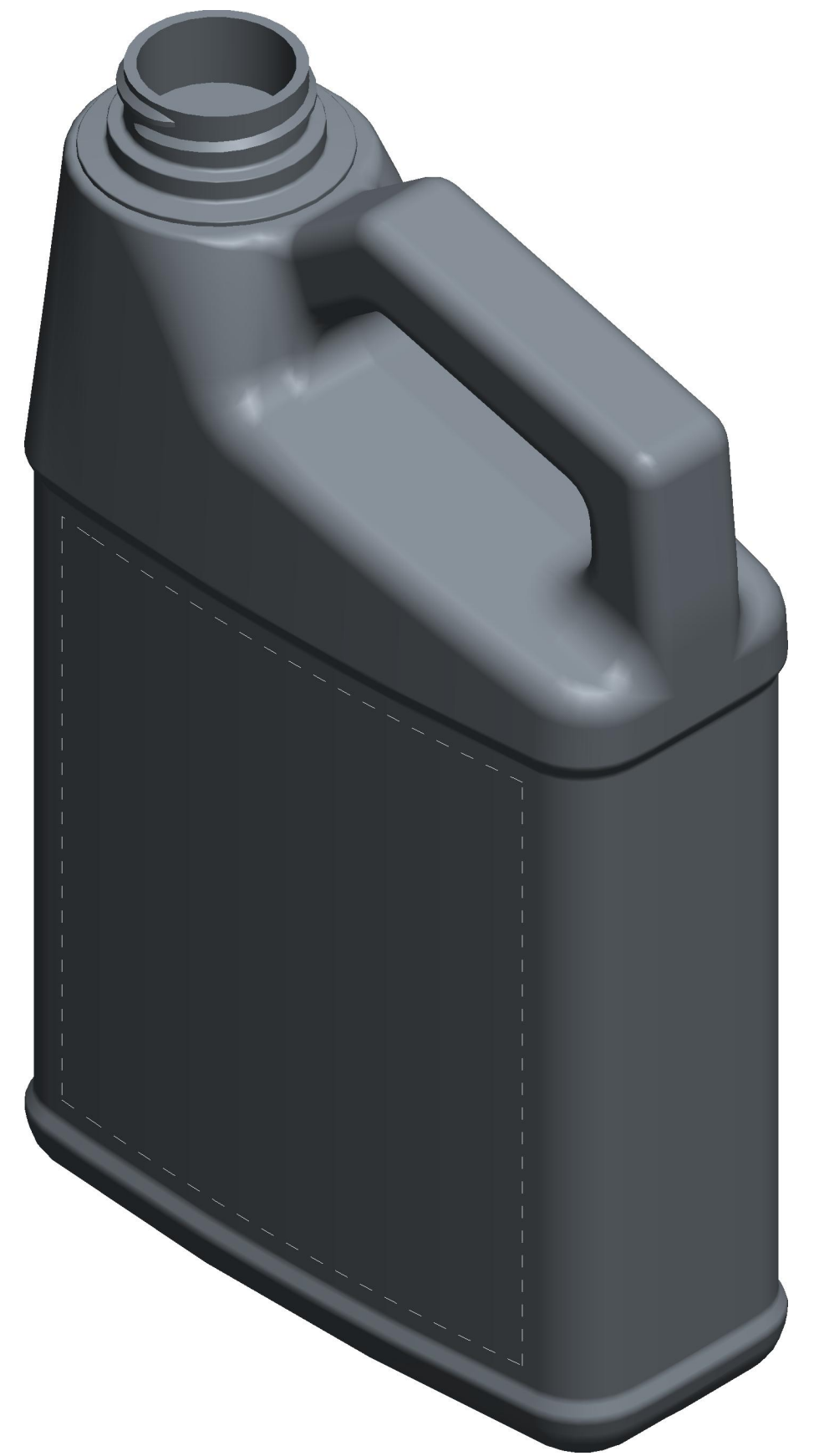
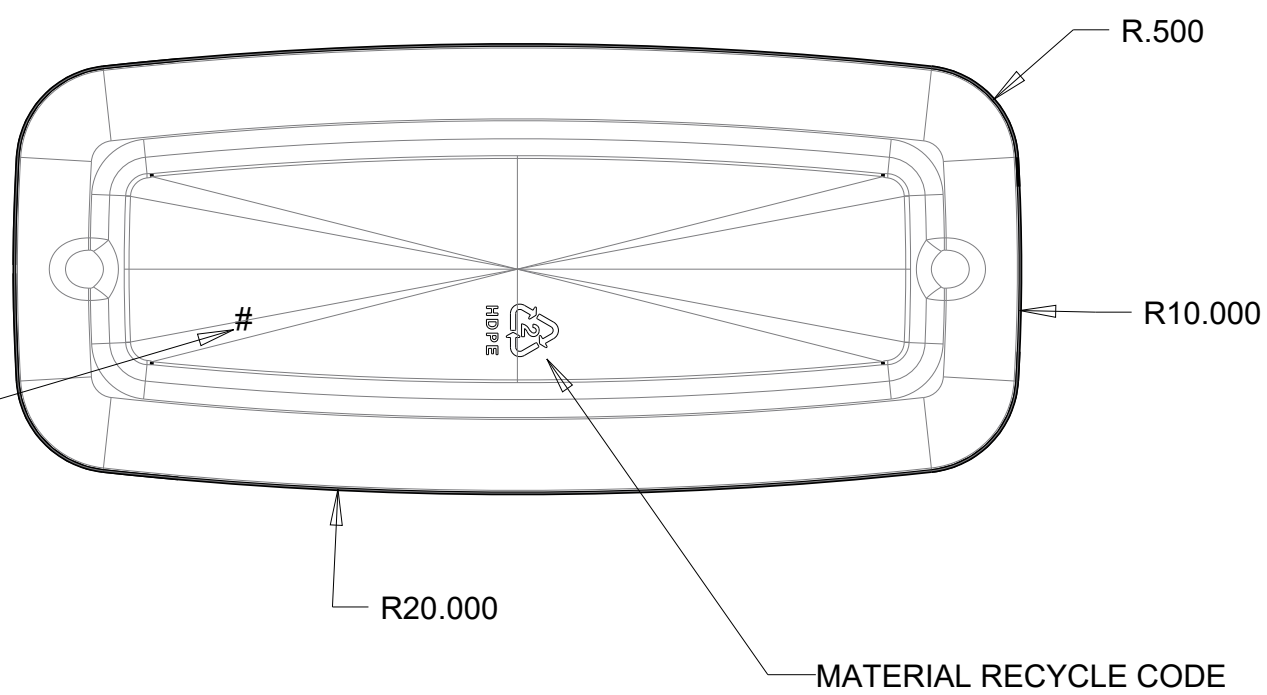
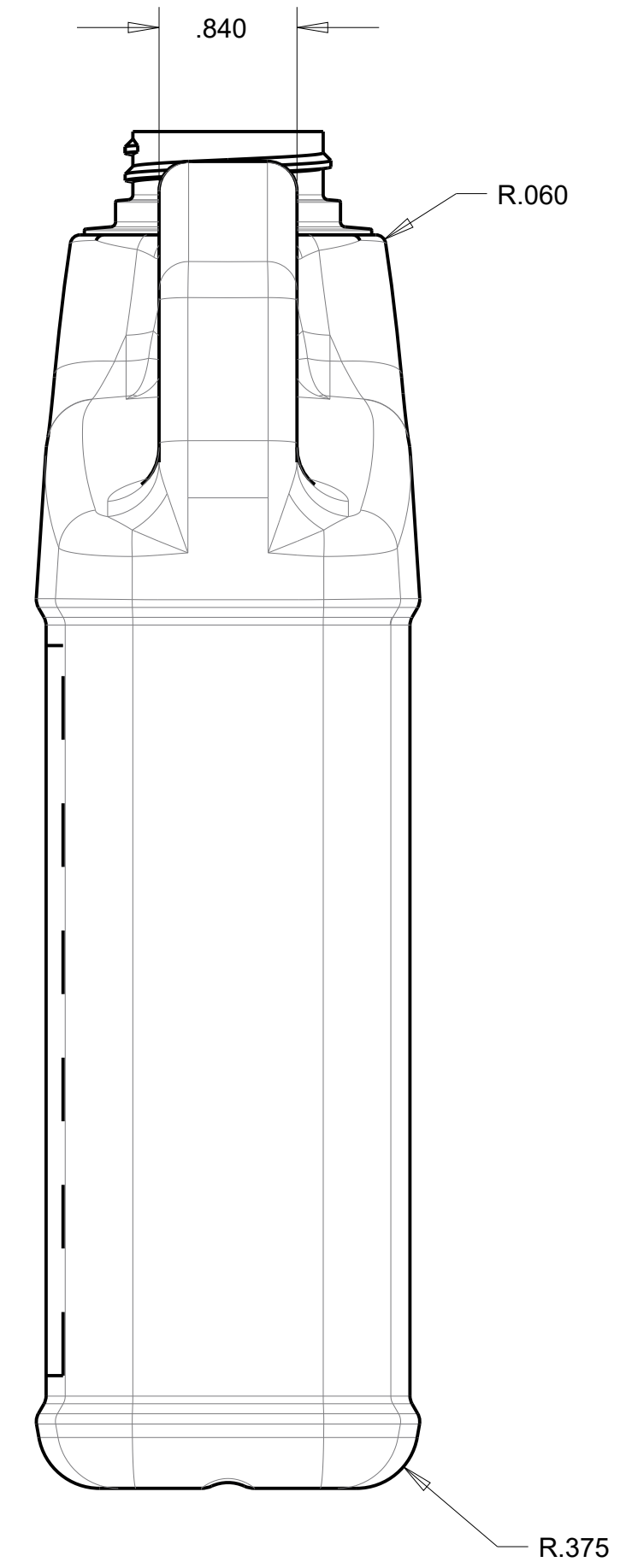
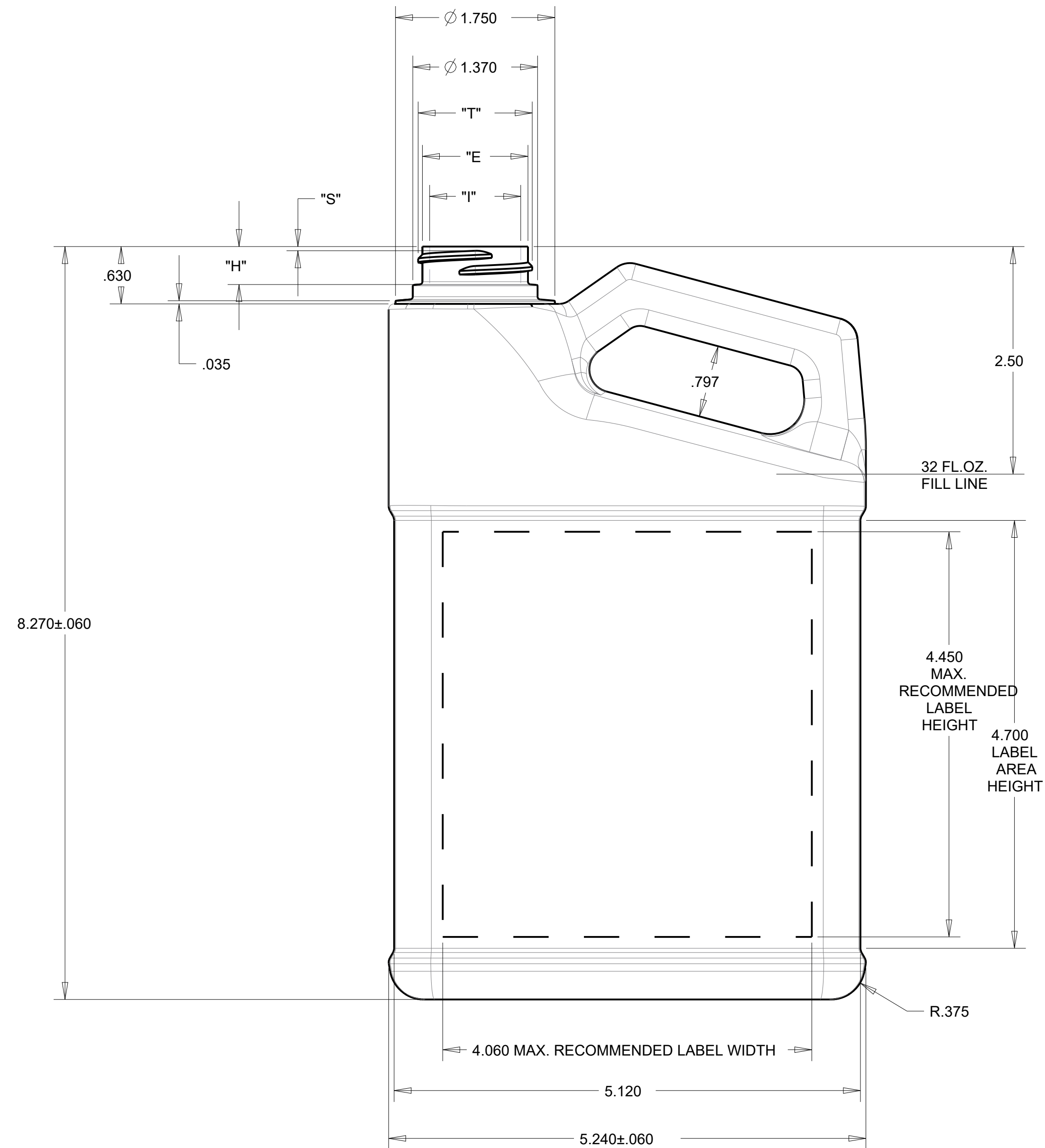
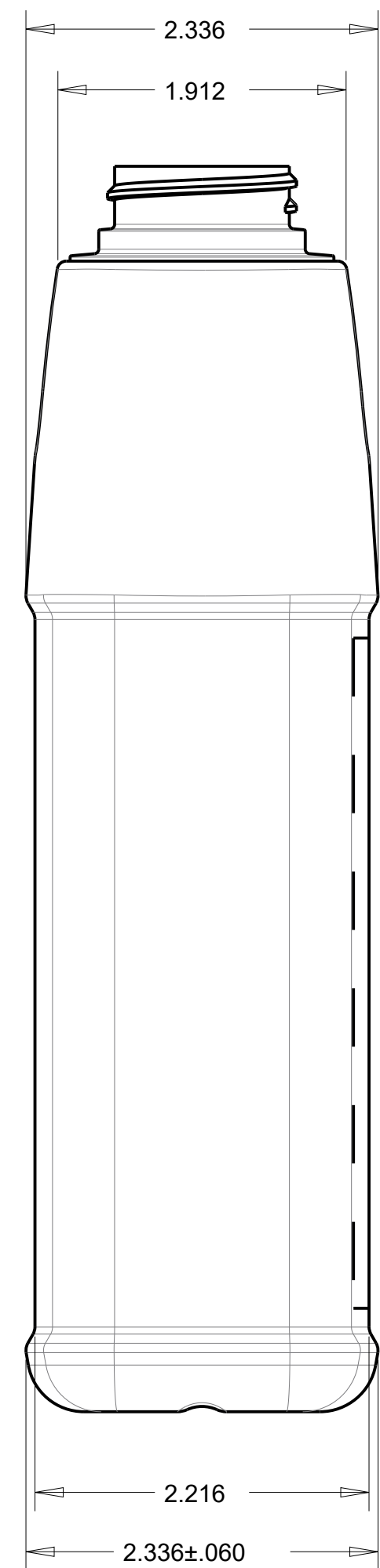
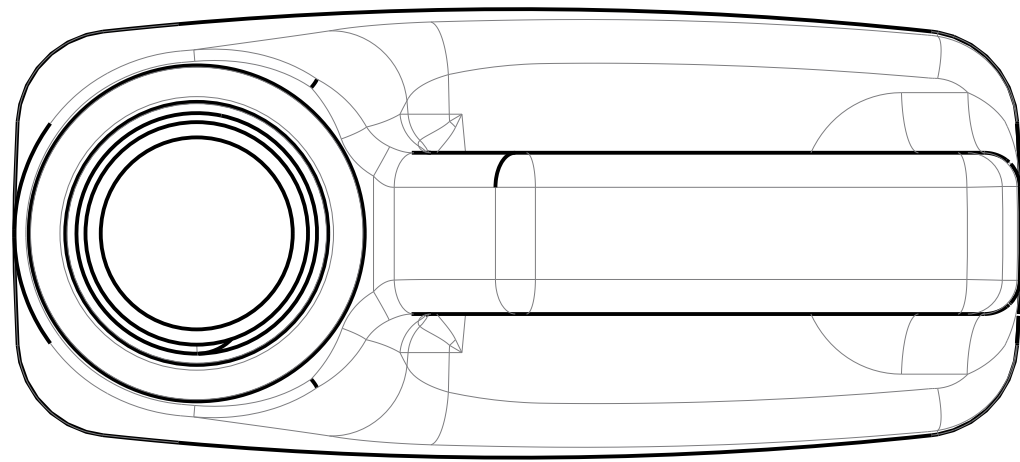

CAVITY NO.'S

MATERIAL RECYCLE CODE

TOLERANCES (EXCEPT AS NOTED)				OCEAN STATE PACKAGING EXTRUSION AND INJECTION BLOW MOLDED BOTTLES	
DECIMAL	MATERIAL	SCALE	DRAWN BY	KSN	
FRACTIONAL	HDPE	FULL	APPROVED BY		
ANGULAR	TITLE	DRAWING NUMBER	DATE	REVISION	MOLD NO.
	32 OZ. SLANT HANDLE	SS-1367-OS	6/1/16		