

- NOTE:
- 1) CONTAINER SPECIFICATIONS PER STANDARD INDUSTRY TOLERANCES.
  - 2) DIMENSIONS IN BRACKETS ARE IN MILLIMETERS
  - 3) PRODUCT & PACKAGING COMPATIBILITY IS TO BE DETERMINED BY USER.
  - 4) CONTAINER DIMENSIONS MAY CHANGE ACCORDING TO WEIGHT AND COLOR

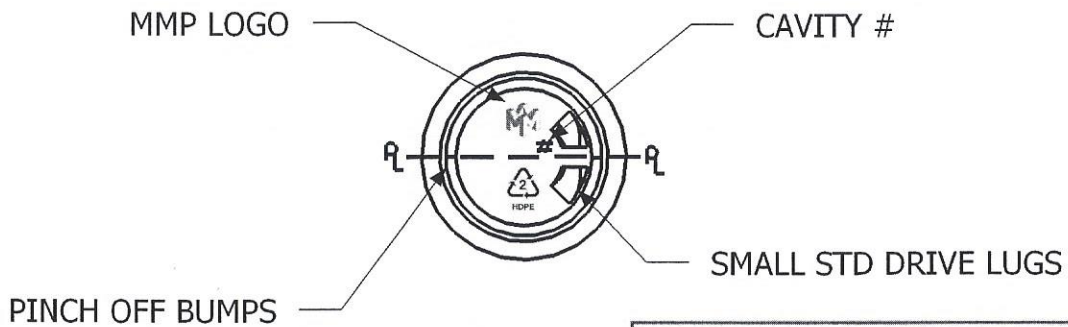

**FOR REFERENCE  
ONLY**

NO	REV. BY:	DESCRIPTION:	DATE:		
NECK FINISH: M24-410SP		GRAM WT.: 24 ±2			
'T'	'E'	'H'	'S'	'L'	'W'
0.932±.008	0.848±.008	0.660±.015	0.046 ±.015		
23.67±.020	21.54±.020	16.76±.038	1.17±.038		
HELIX /	T.P.I.:	CUTT. DIA.:			
CAPACITY TO FILL LEVEL BEFORE DECORATING: 12oz ( 355ML )					
CAPACITY TO FILL LEVEL AFTER DECORATING					
OVERFLOW CAPACITY BEFORE DECORATING: 378ML +-10ML					
OVERFLOW CAPACITY AFTER DECORATING					
DRAWN BY: AB			DESC: 12oz/355ml CYLINDER		
DATE: AUG 13,09			DRAWING NO.:		
BTLE MAT'L: HDPE			MOLD NO.: MMP#1004A		