

NECK FINISH	BOTTLE WEIGHT ±1.5 GRMS	OVERFLOW CAPACITY ±9 CC	"T" DIA.	"E" DIA.	"H" DIM.	"S" DIM.	"I" DIA.
M28SP400	43.0	540.0 *	1.088 1.068	.994 .974	.418 .388	.061 .031	.614 MIN.

DATE	SYM	REVISION	BY
12/21/12	A	INCREASED BODY DIAMETER .030	KSN
		.310 DIM. WAS .375	
		540 CC WAS 530 CC	

* OVERFLOW CAPACITY IS BEFORE DECO

ONE FULL TURN OF THREAD

6 THREADS PER INCH

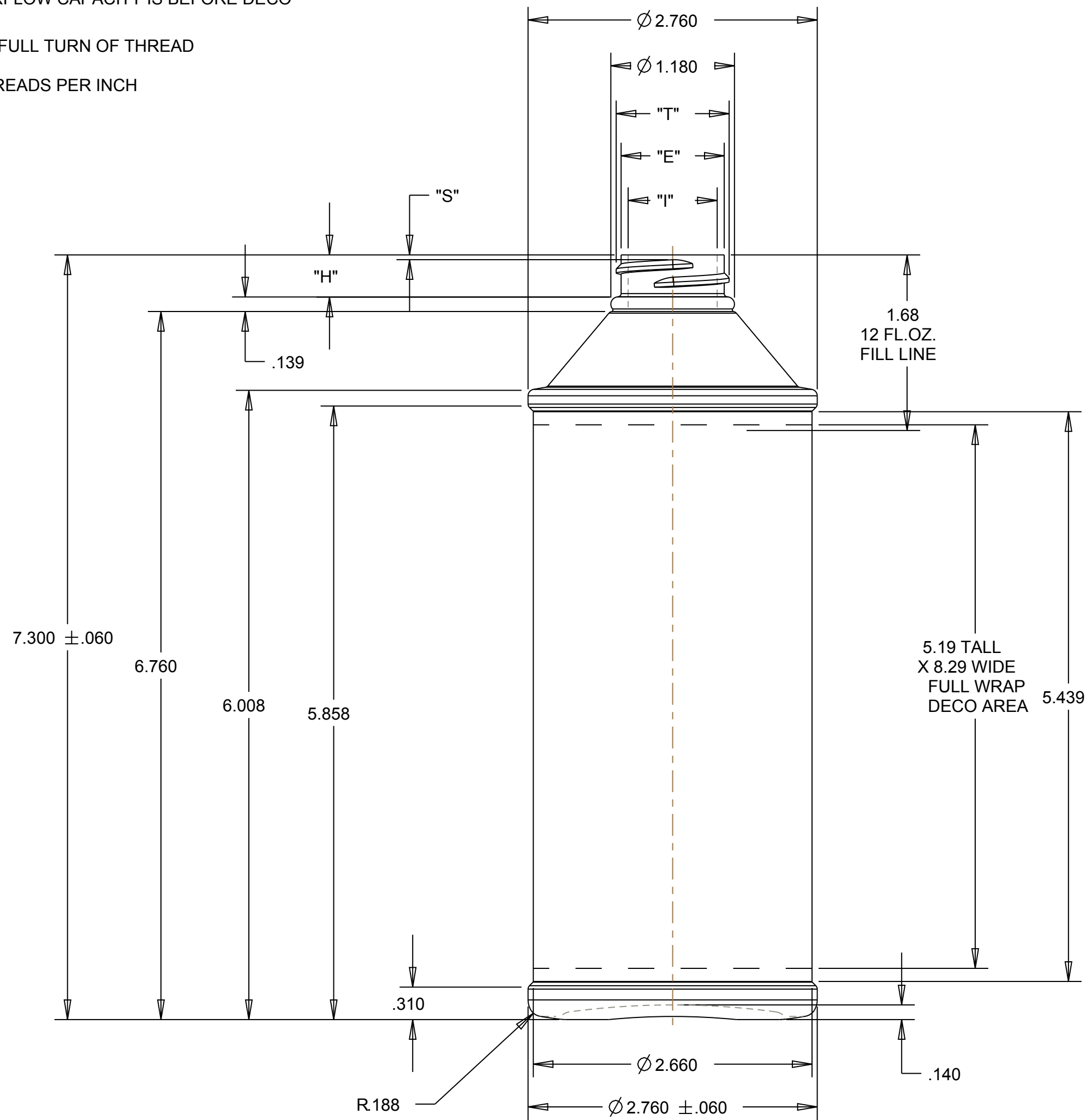

MATERIAL CODE

DECO DRIVE LUGS

CAVITY NUMBER

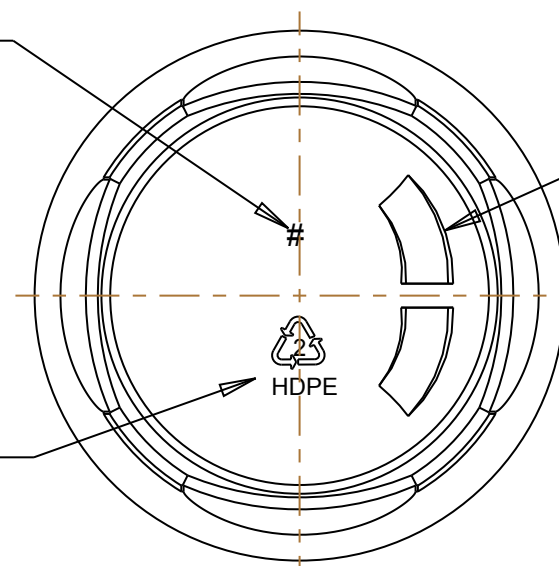

OCEAN STATE PACKAGING EXTRUSION AND INJECTION BLOW MOLDED BOTTLES			
TOL S.P.I.	TITLE 16 OZ BRAKE FLUID		
DATE 11/15/12	DRAWING NO. SS-1205-OS	REV A	