

NECK FINISH	BOTTLE WEIGHT (± 1.5 GR)	OVERFLOW CAPACITY (± 11 CC)	"T" DIA	"E" DIA	"H" DIM	"S" DIM	"I" DIA	MATERIAL
28-410	30	516.5	1.088 1.068	.994 .974	.854 .824	.058 .028	.614 MIN.	PETE

DATE	SYM	REVISION RECORD	AUTH	DR	CK
8/3/16	A	REMOVED NECK PLATFORM Ø 2.712 WAS Ø 2.720 "H" WAS .745/.715		DC	
8/26/16	B	ADDED MOLD ID NO. MOVED CAVITY NO.		DC	

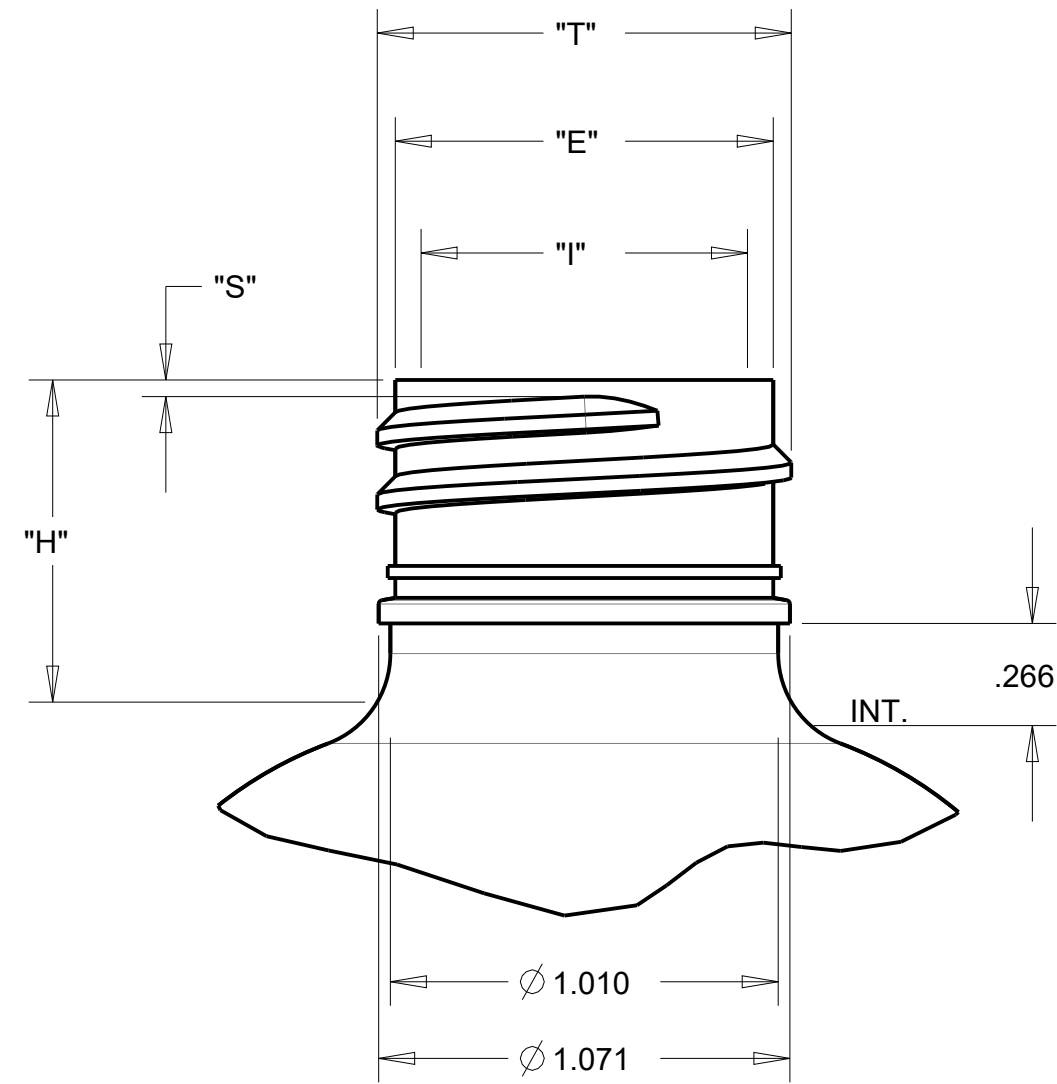

DETAIL A  
SCALE 2.000  
"M" STYLE THREAD  
6 THREADS PER INCH  
PITCH - .167  
1.5 FULL TURNS OF THREAD

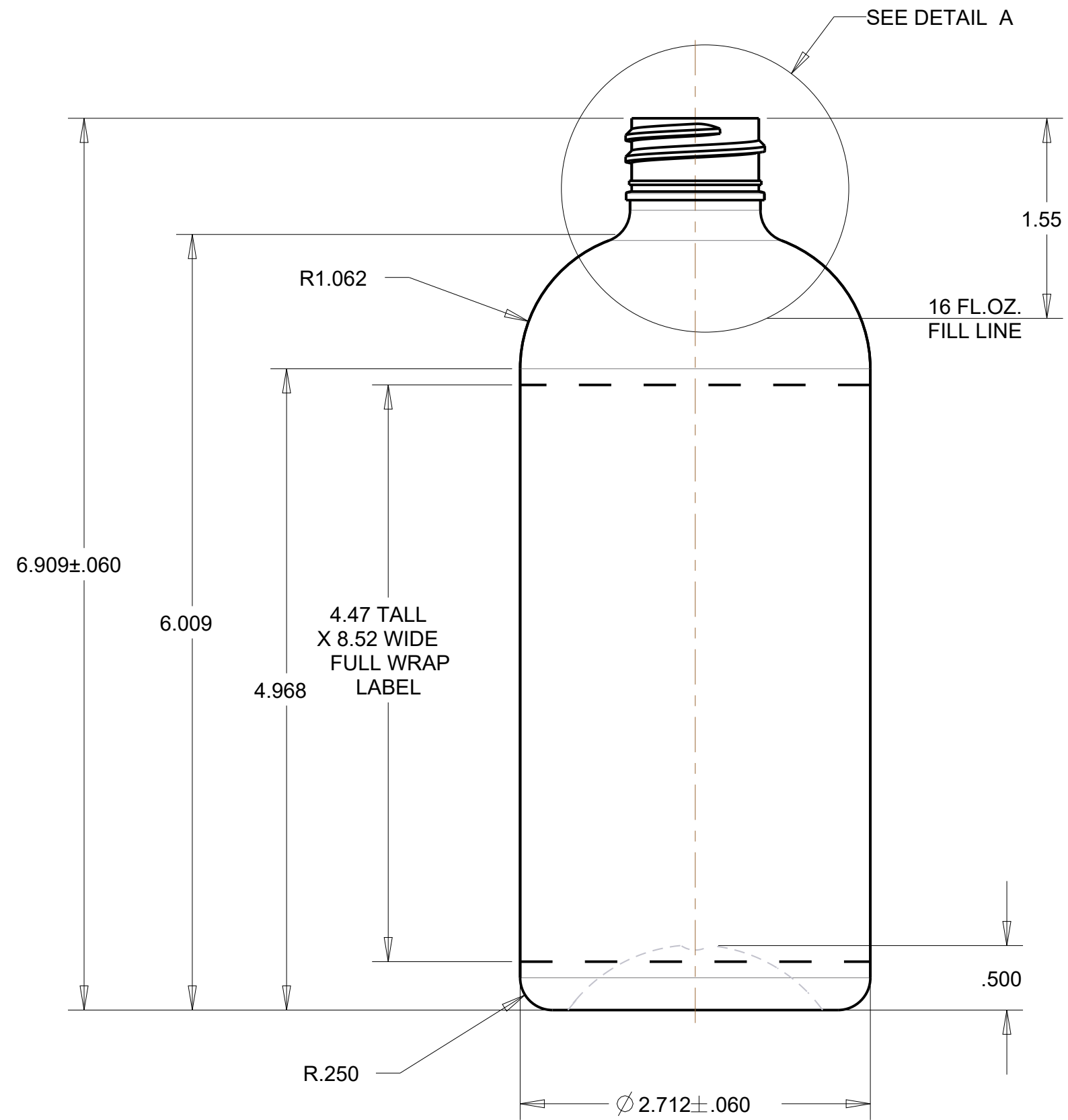
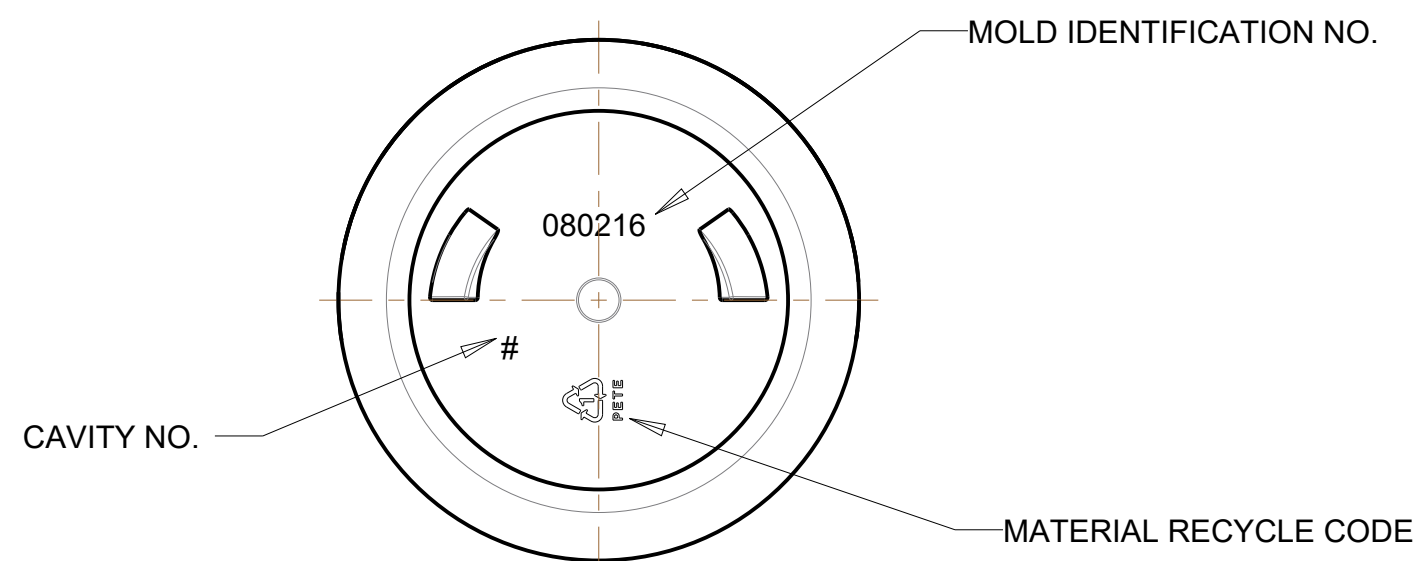
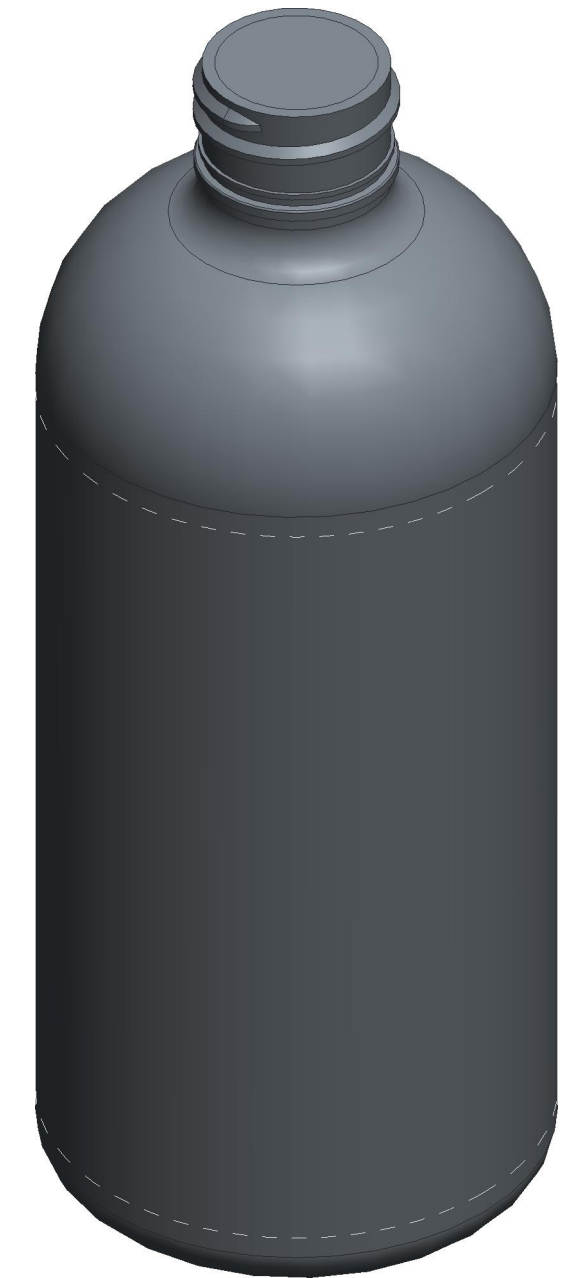

TOLERANCES (EXCEPT AS NOTED)		OCEAN STATE PACKAGING EXTRUSION AND INJECTION BLOW MOLDED BOTTLES			
DECIMAL	MATERIAL	SCALE	DRAWN BY		
S.P.I.	PETE	FULL	KSN		
FRACTIONAL	TITLE	APPROVED BY		MOLD NO	
S.P.I.	16 OZ. BOSTON ROUND				
ANGULAR	DATE	DRAWING NUMBER	REVISION		
S.P.I.	7/27/16	SS-1373-OS	B		