

NUMBER	REVISIONS	REV. BY	DATE
△			

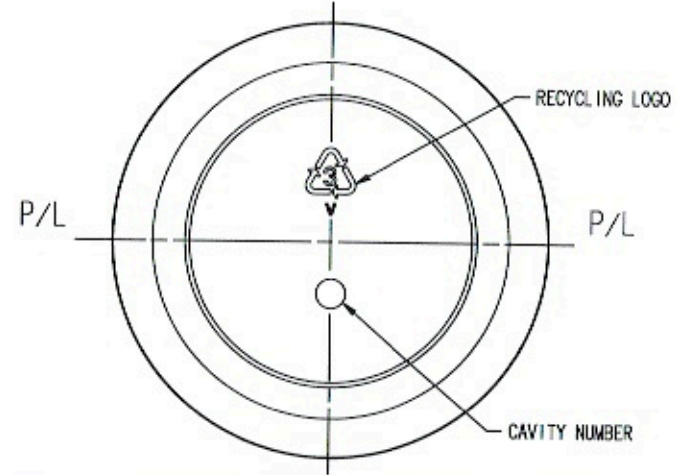
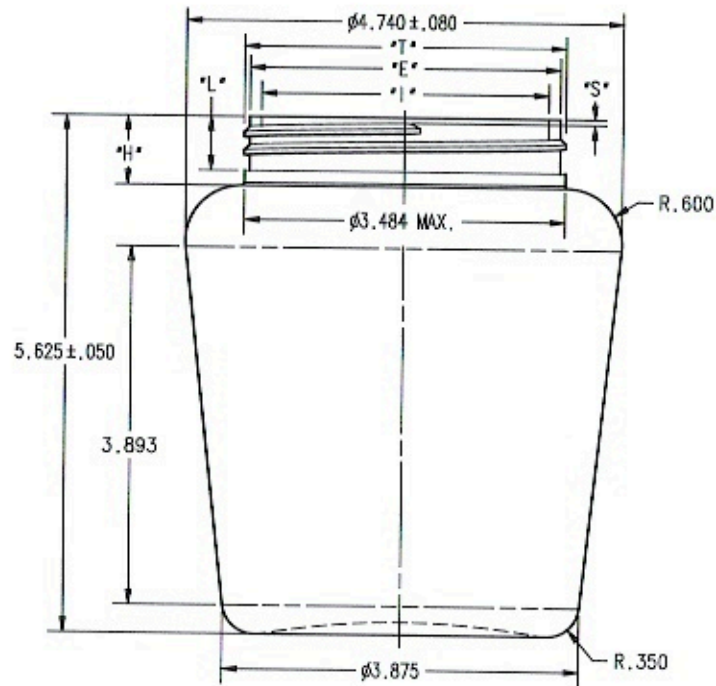

1. BODY SIZES SHOWN ARE REPRESENTATIVE OF MEAN DIMENSIONS ONLY. FINAL PLASTIC SIZES ARE TO BE DETERMINED FROM ACTUAL PLASTIC SAMPLES.
2. ALL DIMENSIONS AND TOLERANCES CONFORM TO SPI STANDARDS WHERE APPLICABLE.
3. THIS DRAWING MAY NOT BE REPRODUCED IN ANY FORM, FOR ANY PURPOSE, UNLESS WRITTEN CONSENT IS GIVEN BY BLOW MOULD ENGINEERING.
4. BLOW MOULD WILL NOT BE RESPONSIBLE FOR THE FUNCTIONALITY OF THE PART. ALL DRAWINGS MUST BE APPROVED BY THE CUSTOMER BEFORE PRODUCTION OF THE MOULD BEGINS.

NOTES:

- ALL DIMENSIONS ARE TO BE IN INCHES UNLESS OTHERWISE SPECIFIED.
- ALL RADS & FILLETS ARE 1/64 R. MIN. UNLESS OTHERWISE SPECIFIED.
- ALL DIMENSIONS & FILL CAPACITIES CONFORM TO S.P.I. STANDARDS.

BOTTLE SPECIFICATIONS			
BOTTLE MAT'L :	PVC	FILL CAPACITY :	1183 (40oz) ± 20 ML
BOTTLE WT :	60 ± 2 G	O/F CAPACITY :	1222 ± 20 ML
NECK SPECIFICATIONS			
FINISH	89MM (SPECIAL)	*L* DIM.	.592
STYLE	W	*W* DIM.	N/A
T DIM.	3.494 ± .018	HELIX ANG	1°4'
E DIM.	3.374 ± .018	T.P.I.	5
I DIM.	3.120	PITCH	.200
BEAD DIA.	SEE DWG.	CUTTER DIA.	1/2
H DIM.	.535 ± .015	# OF TURNS	1.5
S DIM.	.06 ± .015		
DWN BY: 124		DATE: FEB.22/06	DESCRIPTION
APR BY:		DATE:	40 oz REVERSED TAPERED JAR
SCALE: 1:1		DRAWING NO.	C80-4000-1-1A