

NO.	REV. BY	DESCRIPTION	DATE
1			

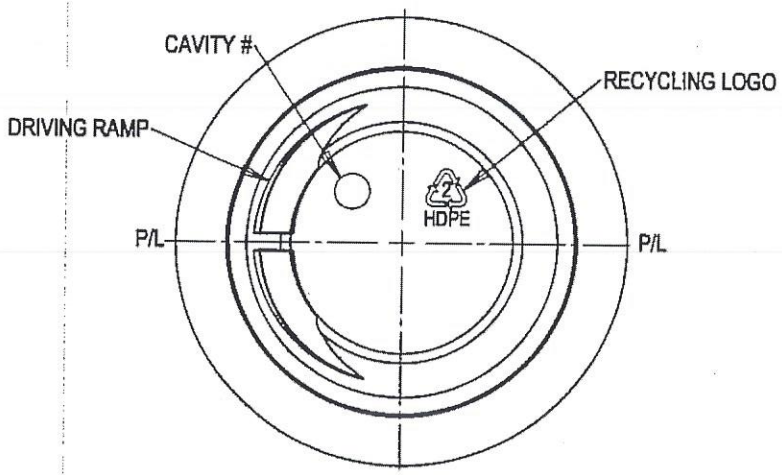
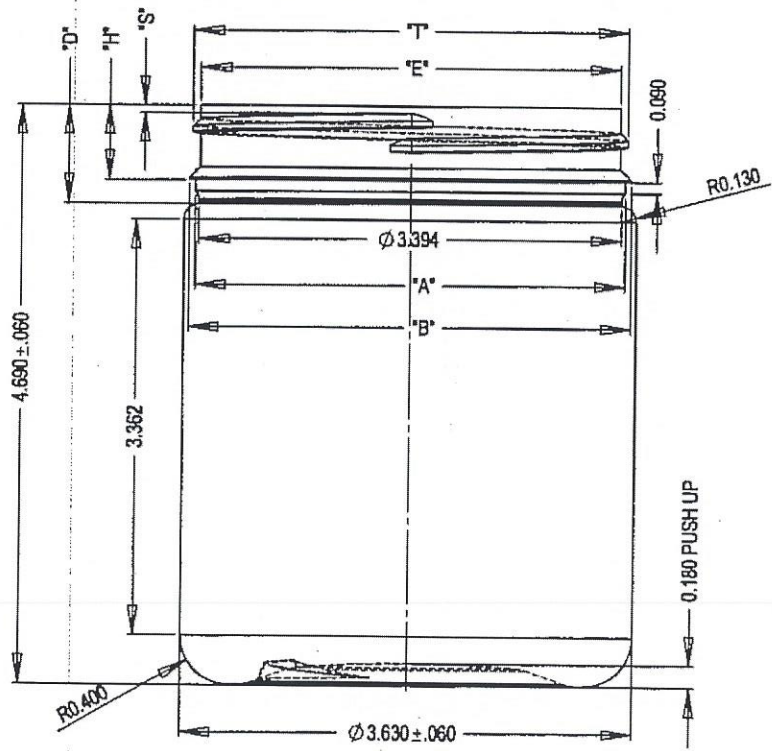

NOTE:  
 - ALL DIMENSIONS ARE TO BE IN INCHES UNLESS SPECIFIED.  
 - ALL RADS & FILLETS ARE 1/64 R. MIN. UNLESS OTHERWISE SPECIFIED.  
 - ALL DIMENSION & FULL CAPACITIES CONFORM TO S.P.I. STANDARDS.

BOTTLE SPECIFICATIONS			
MATERIAL:	HDPE	FILL CAPACITY:	
WEIGHT:	45g ± 2g	OF CAPACITY:	714 ML ± 13ML
NECK SPECIFICATIONS			
FINISH	RSWIM PA/O	"A" DIM	3.450 ± .017
STYLE	M	"B" DIM	3.650 ± .017
"T" DIM	Ø 3.493 ± .017	HELIX ANG.	1° ±
"E" DIM	Ø 3.373 ± .017	T.P.I	9
"I" DIM	N/A	PINCH	.200
"D" DIA.	800 MIN	CUTTER DIA.	.500
"H" DIM.	808 ± .015	THREAD TURNS	1
"S" DIM	060 ± .015		

- BODY SIZES SHOWN ARE REPRESENTATIVE OF MEAN DIMENSIONS ONLY. FINAL PRODUCT SIZES ARE TO BE DETERMINED FROM ACTUAL PLASTIC SAMPLES.
- ALL DIMENSIONS AND TOLERANCES CONFORM TO S.P.I. STANDARDS WHERE APPLICABLE.
- THIS DRAWING MAY NOT BE REPRODUCED IN ANY FORM FOR ANY PURPOSE, UNLESS WRITTEN CONSENT IS GIVEN BY BLOW MOULD ENGINEERING.
- BLOW MOULD ENGINEERING WILL NOT BE RESPONSIBLE FOR THE FUNCTIONALITY OF THE PART. ALL DRAWINGS MUST BE APPROVED BY THE CUSTOMER BEFORE PRODUCTION OF THE MOULD BEGINS.

DWN. BY: Y.F.	DATE: 05/08/13	DESCRIPTION:	625 ML JAR
APR. BY:	DATE:	DRAWING NO.:	C33-4025-1-1A
SCALE: 1:1			