

Compact Mould

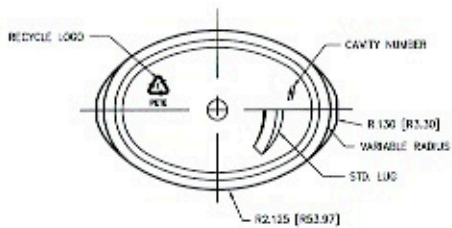
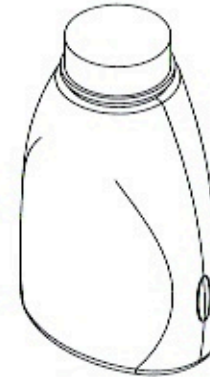
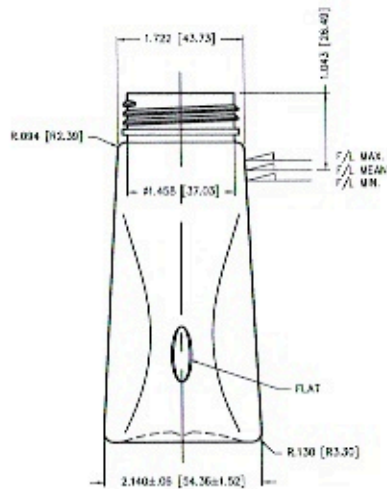
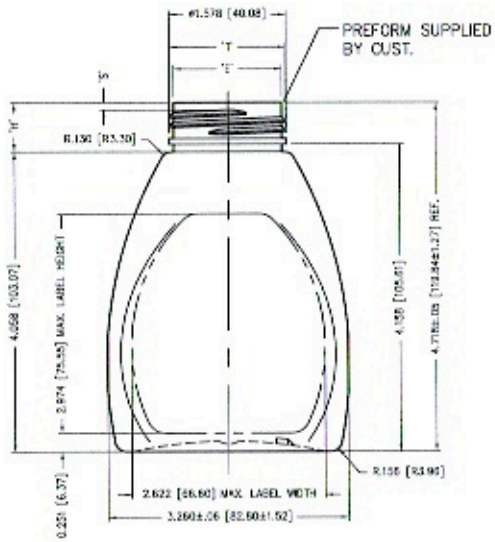

TEMPORARY DRAWING

THIS IS A SUGGESTED DESIGN FOR CUSTOMER APPROVAL. FINAL SIZES AND SPECIFICATIONS ARE SUBJECT TO FINAL PRODUCTION QUALIFICATIONS.

NO.	REV.	BY	DESCRIPTION	DATE	
NECK FINISH:			40mm SPECIAL	GRAM WT. 26.0g ±.5	
T	E	H	S	V	W
1.595 ±.015	1.455 ±.015	.660 ±.015	.100 ±.015		
39.75 ±.38	37.03 ±.38	15.76 ±.35	2.54 ±.38		
HELIX <: 1° 30'		T.P.L.: 6	CUTT. DIA.: 90(13.70)		
CAPACITY TO FILL LEVEL BEFORE DECORATING				259.0ml ±.7	
CAPACITY TO FILL LEVEL AFTER DECORATING					
OVERFLOW CAPACITY BEFORE DECORATING				297.0ml ±.7	
OVERFLOW CAPACITY AFTER DECORATING					
DRAWN BY: 255			DESC: 8.75oz. OVAL FOAMER		
SCALE: 1:1			DATE: JAN 15/06		
BOTTLE MATL: PETE			DRAWING NO: 49-30790-PD		
CAD NAME: PD\49-30790-PD			MOLD NO.		

STANDARD ORDER SPECIFICATIONS FOR:
 NECK FINISH _____
 BODY _____
 CAPACITY _____
 FINISH _____
 SPECIAL FEATURES _____
 PRODUCT BEING TO BE OFFERED BEFORE MOLD OFFERS ARE MADE:
 APPROVED BY _____
 DATE _____
 ALL DIMENSIONS UNLESS OTHERWISE SPECIFIED