

| REV | DATE | DESCRIPTION | DWN BY | APPR |
|-----|------|-------------|--------|------|
| | | | | |
| | | | | |
| | | | | |

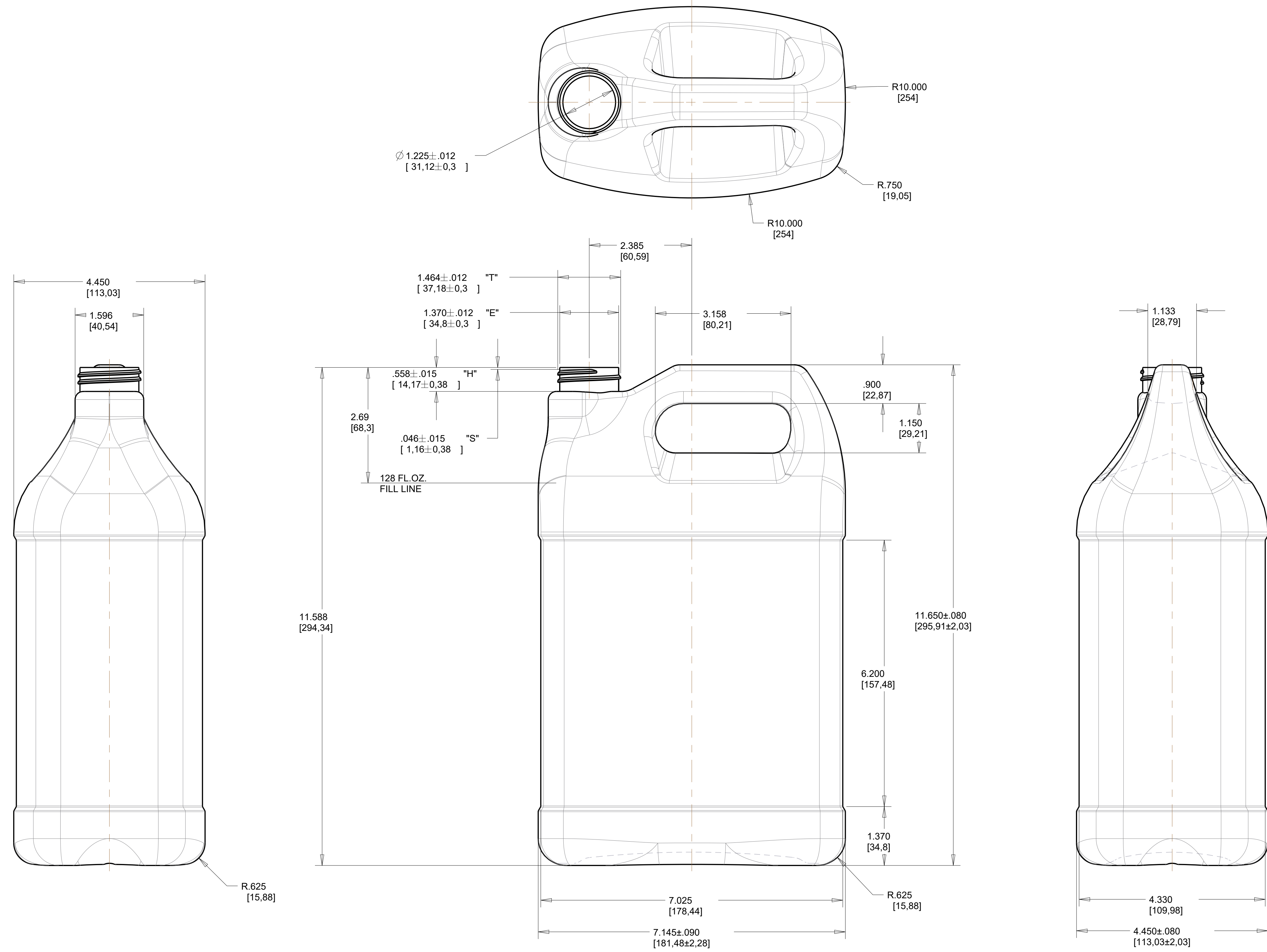

OVERFLOW CAPACITY - 4148 ± 44 ML
(INCLUDES 22ML BULGE)

BOTTLE WEIGHT - 150 ± 5 GRAMS

38-400 NECK FINISH
"M" STYLE THREAD
6 T.P.I
PITCH- .167
1-1/2 FULL TURNS OF THREAD

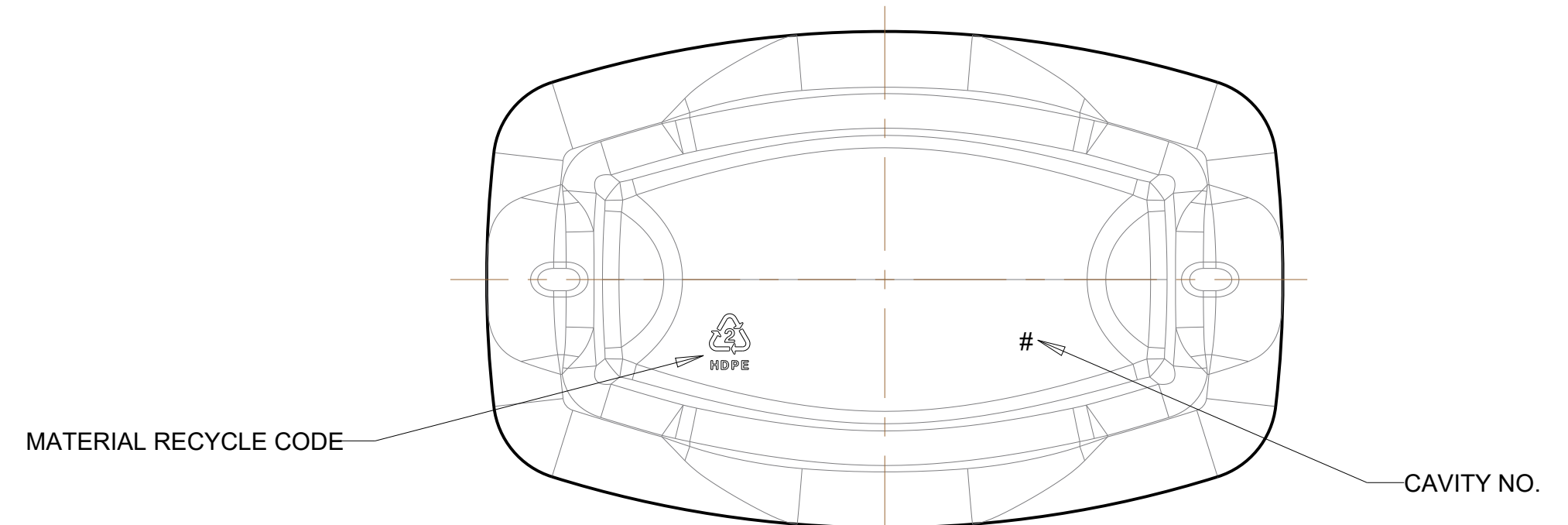

| TOLERANCES (EXCEPT AS NOTED) | | | | |
|------------------------------|----------|------------------|-------------|----------|
| DECIMAL | MATERIAL | SCALE | DRAWN BY | KSN |
| | HDPE | | APPROVED BY | |
| FRACTIONAL | TITLE | 1 GALLON F-STYLE | | MOLD NO. |
| ANGULAR | DATE | DRAWING NUMBER | SS-1542-OS | REVISION |
| | 2/27/20 | | | |