

NO.	REV BY	DESCRIPTION	DATE
1	AP	MOULD ID NO CHANGE	03/03/17

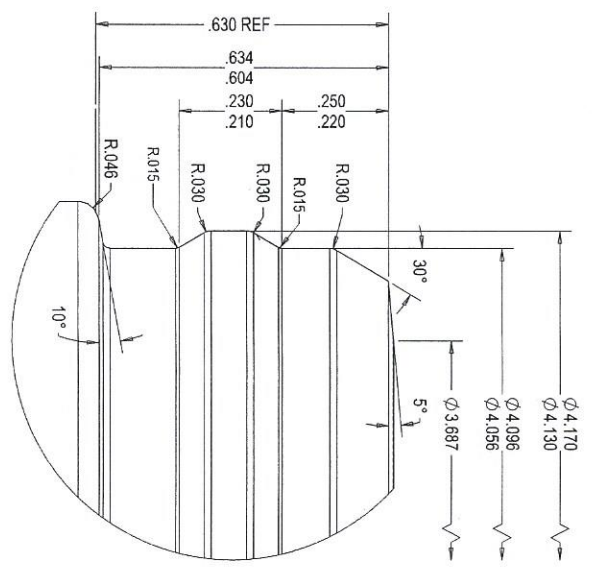

DETAIL A  
SCALE 5:1

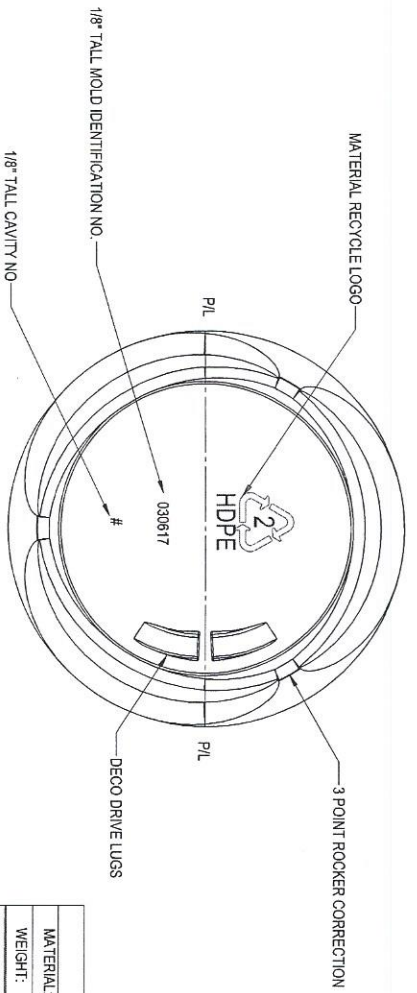
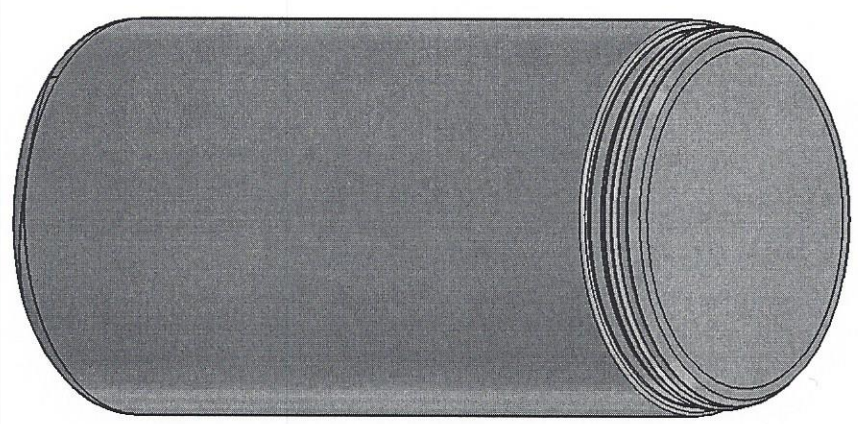
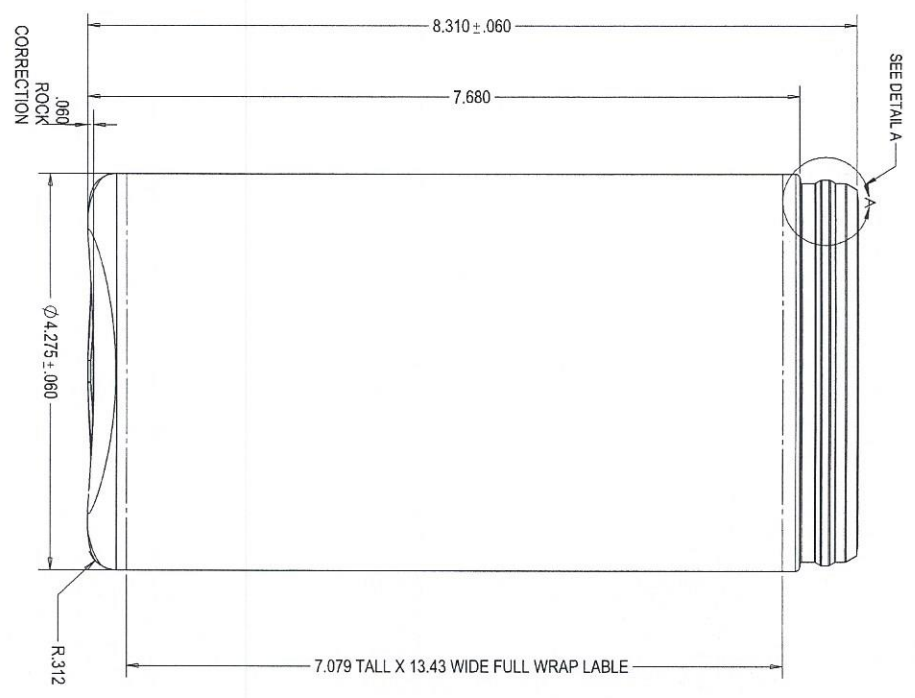

MATERIAL RECYCLE LOGO

1/8" TALL MOLD IDENTIFICATION NO.

1/8" TALL CAVITY NO.

BOTTLE SPECIFICATIONS			
MATERIAL:	HDPE	FILL CAPACITY:	NA
WEIGHT:	70 ± 3.5GM	O/F CAPACITY:	185ML ± 24ML
DWN BY: AP	DATE: 03/03/2017	DESCRIPTION:	105 CANISTER NECK 1B
APR BY:	DATE:	DRAWING NO.:	C93-4187-1-1B
SCALE: 1:1			

NOTE:

CAVITY NUMBERS SHOULD BE 5 TO 10