

| DATE | SYM | REVISION RECORD | AUTH | DR | CK |
|---------|-----|---|------|----|-----|
| 1/14/21 | A | .655 "H" WAS .640, 1.190 RATCHET OD WAS 1.170, 3.630 DIM WAS 3.626, ADDED .039 "S" DIM, .360 WAS .380 | | | KSN |
| 1/18/21 | B | 38 GRAM WEIGHT WAS 35 G, OFC 559ML WAS 562ML | | | KSN |

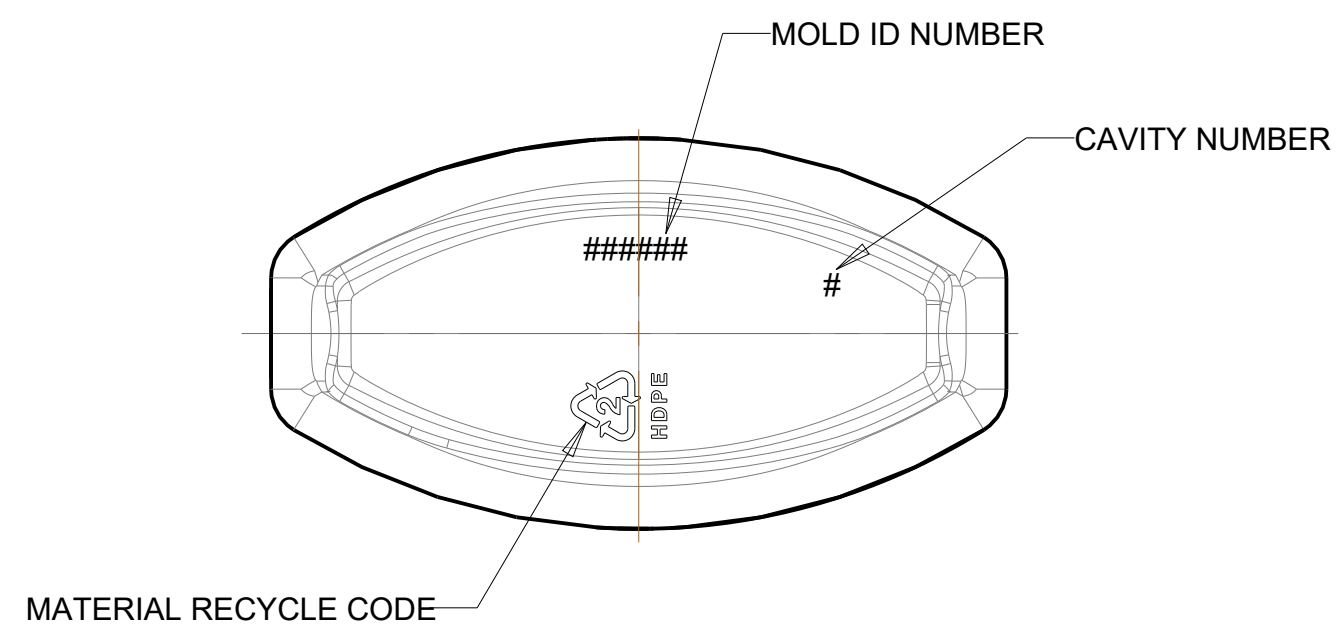
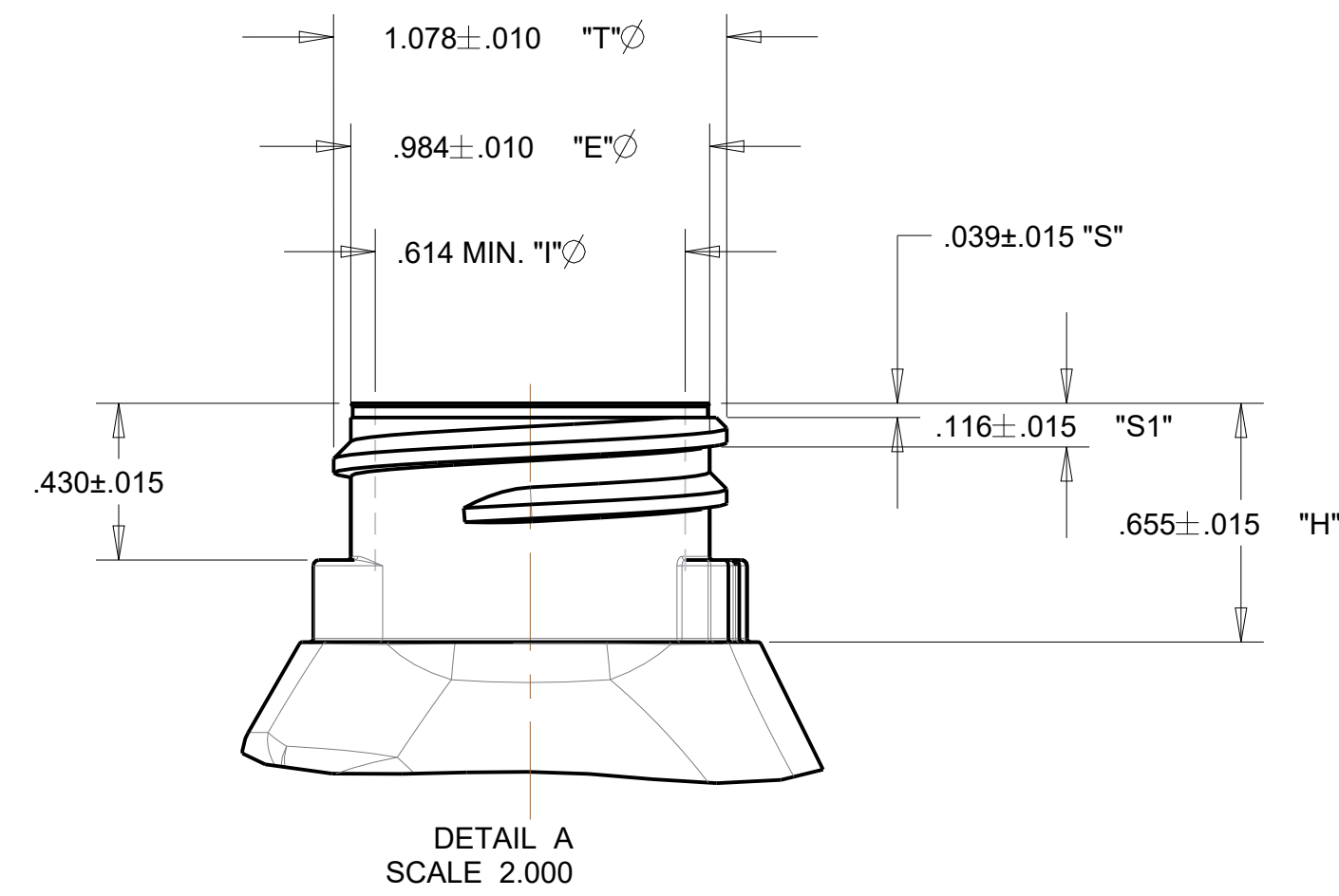
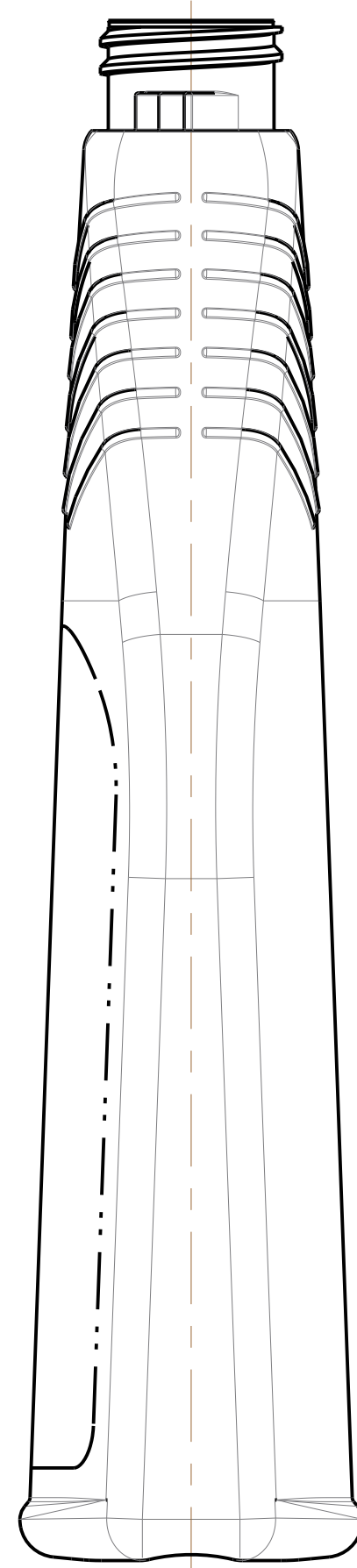
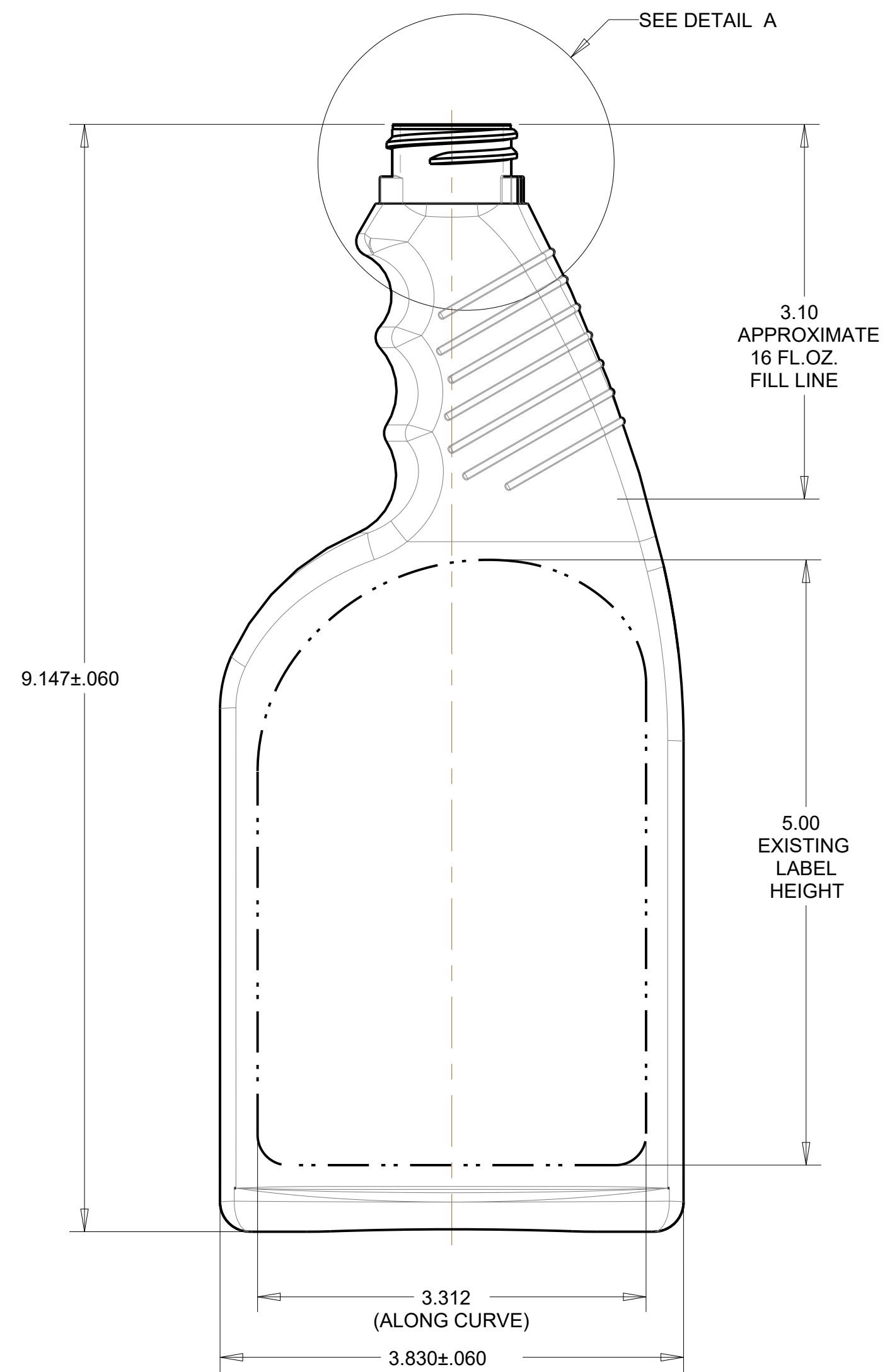
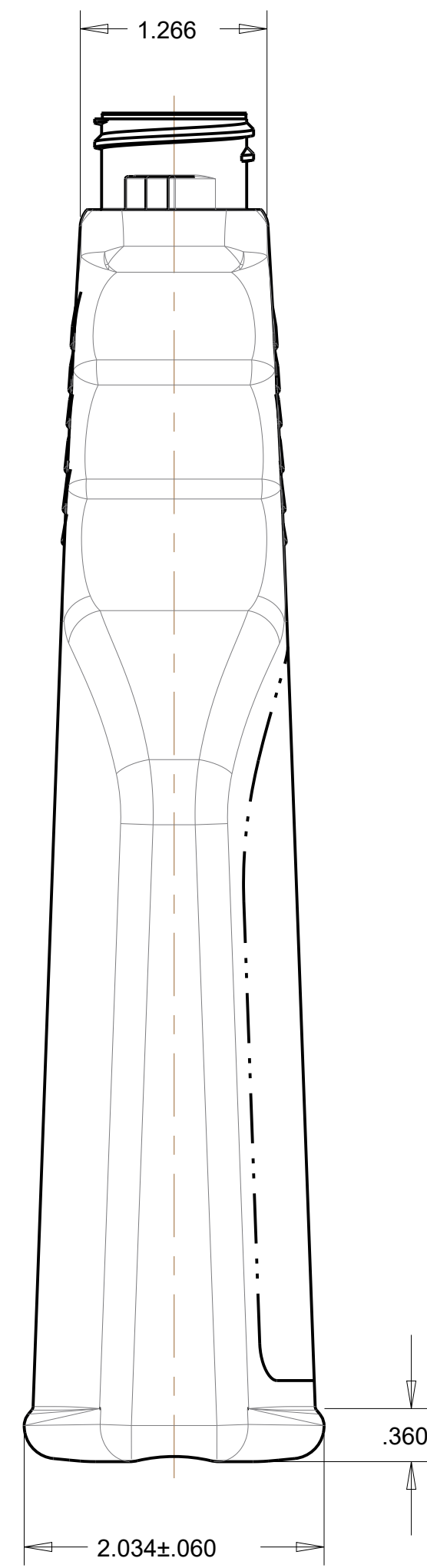
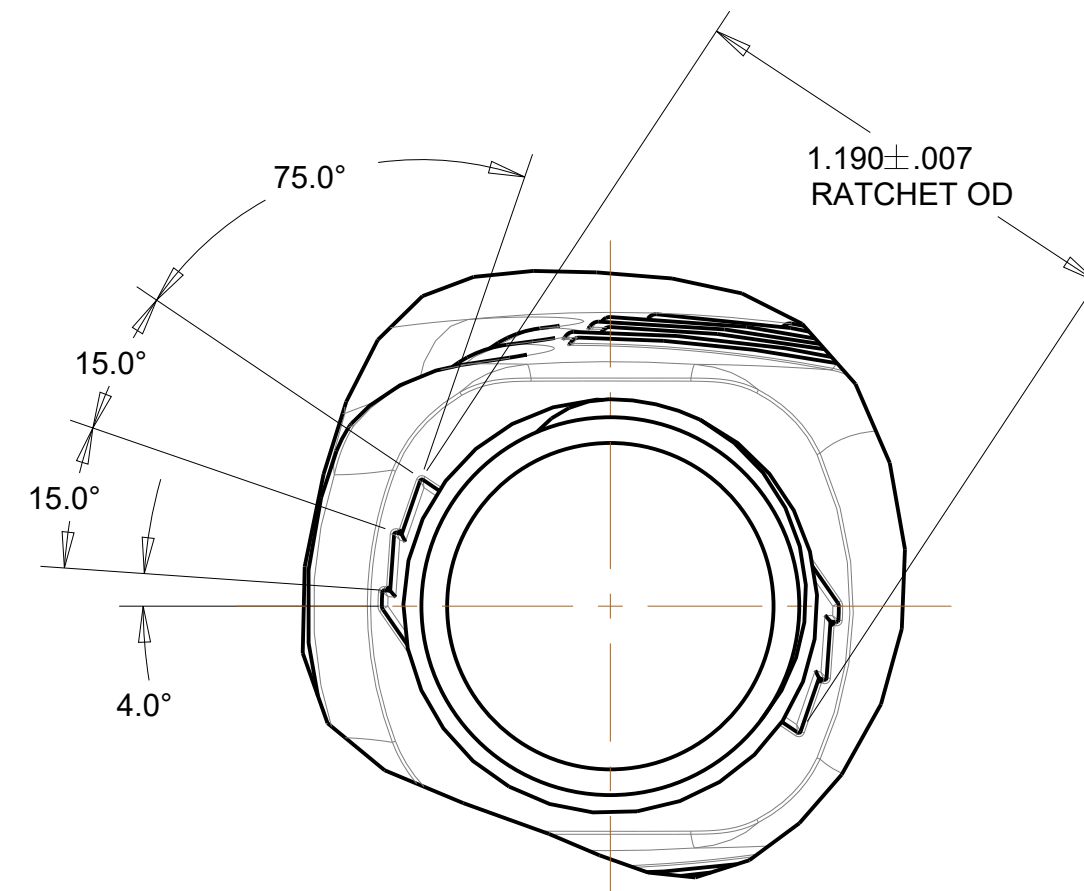
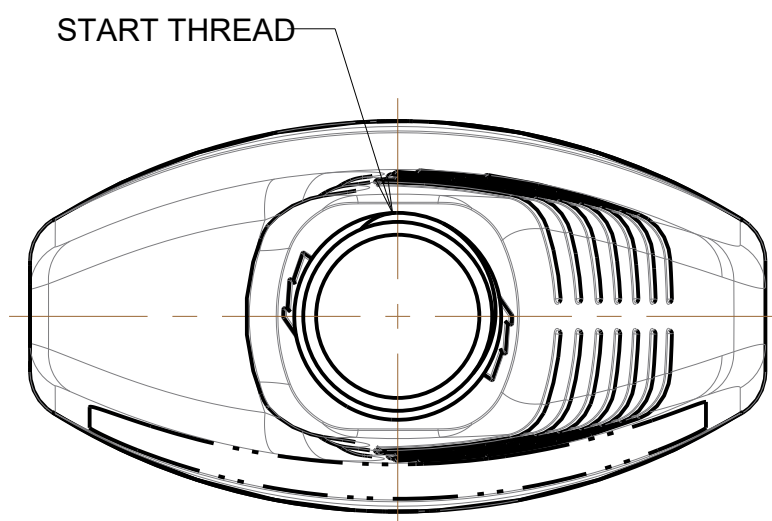

NOTES:

1. MATERIAL- HDPE
2. WEIGHT- 38 ± 2 GRAMS
3. OVERFLOW CAPACITY- 559 ± 13 ML (INCLUDES 5ML BULGE)
4. NECK FINISH- 28-410 SPECIAL RATCHET 6 THREADS PER INCH PITCH. .167 "M" STYLE THREAD 1-1/2 FULL TURNS OF THREAD

| OCEAN STATE PACKAGING EXTRUSION AND INJECTION BLOW MOLDED BOTTLES | | | | |
|--|----------|-----------------------|-------------|----------|
| TOLERANCES (EXCEPT AS NOTED) | MATERIAL | SCALE | DRAWN BY | KSN |
| | HDPE | FULL | APPROVED BY | |
| FRACTIONAL | TITLE | 16 OZ. PISTOL SPRAYER | | MOLD NO. |
| ANGULAR | DATE | DRAWING NUMBER | REVISION | |
| | 12/28/20 | SS-1574-OS | B | |