

NECK FINISH	BOTTLE WEIGHT (± 2 GR)	OVERFLOW CAPACITY (± 11 CC)	"T" DIA	"E" DIA	"H" DIM	"S" DIM	"I" DIA	MATERIAL
M28SP400	38.0	570.0	1.088 1.068	.994 .974	.468 .438	.061 .031	.614 MIN.	HDPE

DATE	SYM	REVISION RECORD	AUTH	DR	CK

NOTES:

1. M STYLE THREAD
2. 6 THREADS PER INCH
3. 1.5 FULL TURNS OF THREAD
4. PITCH - .167

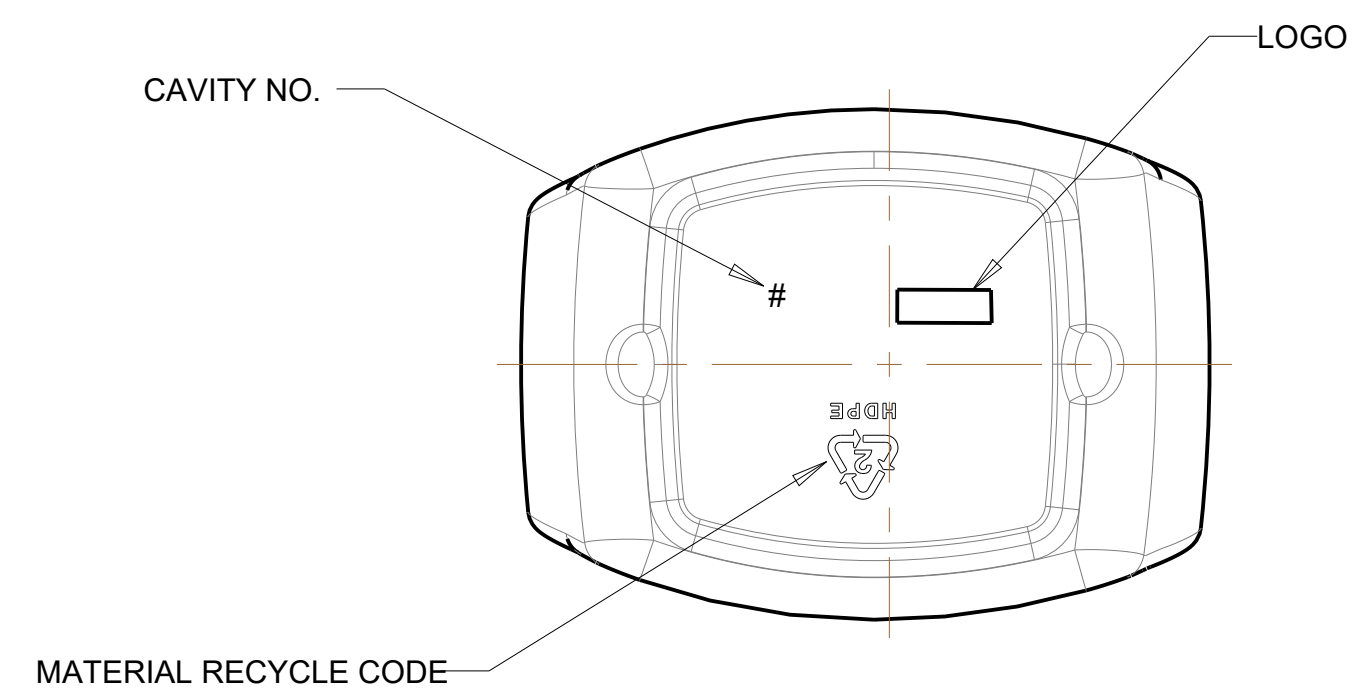
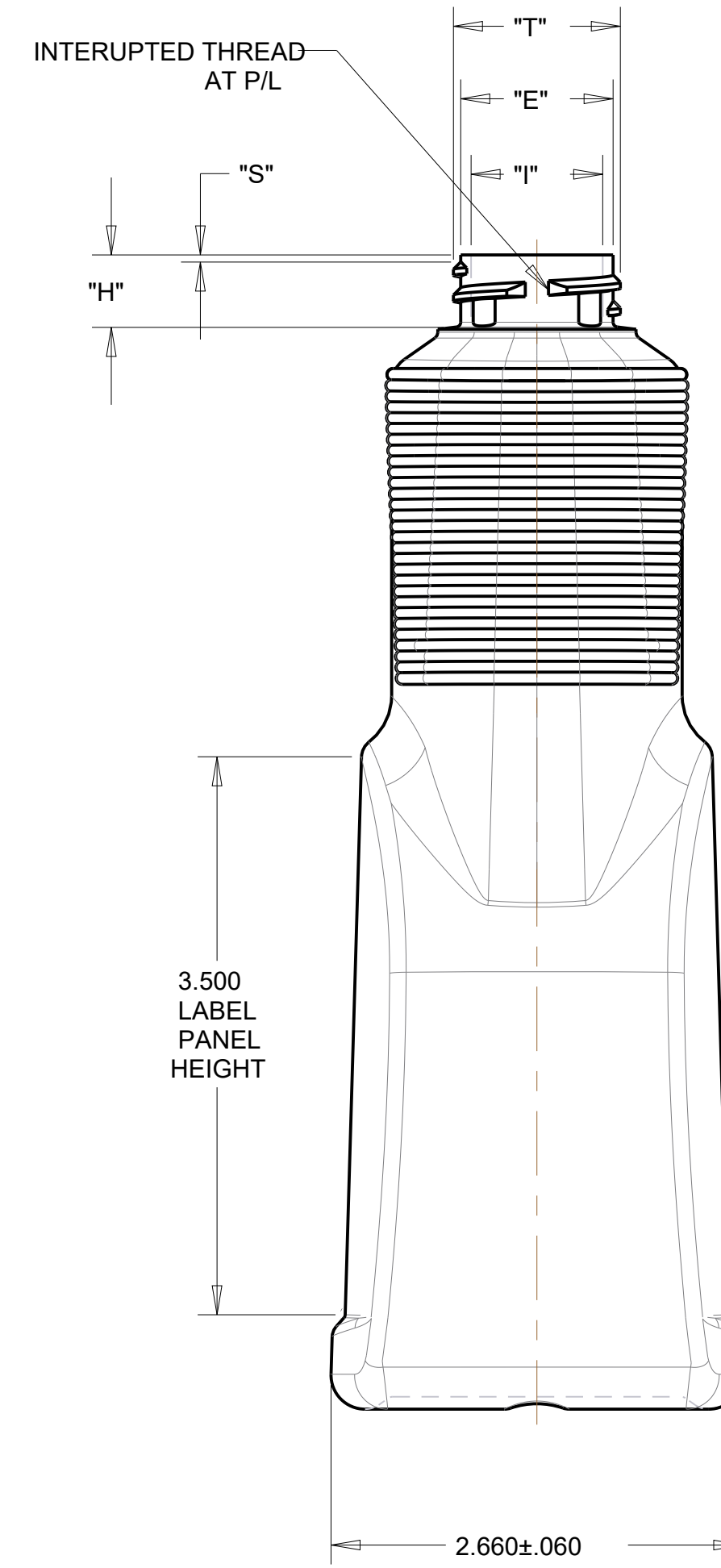
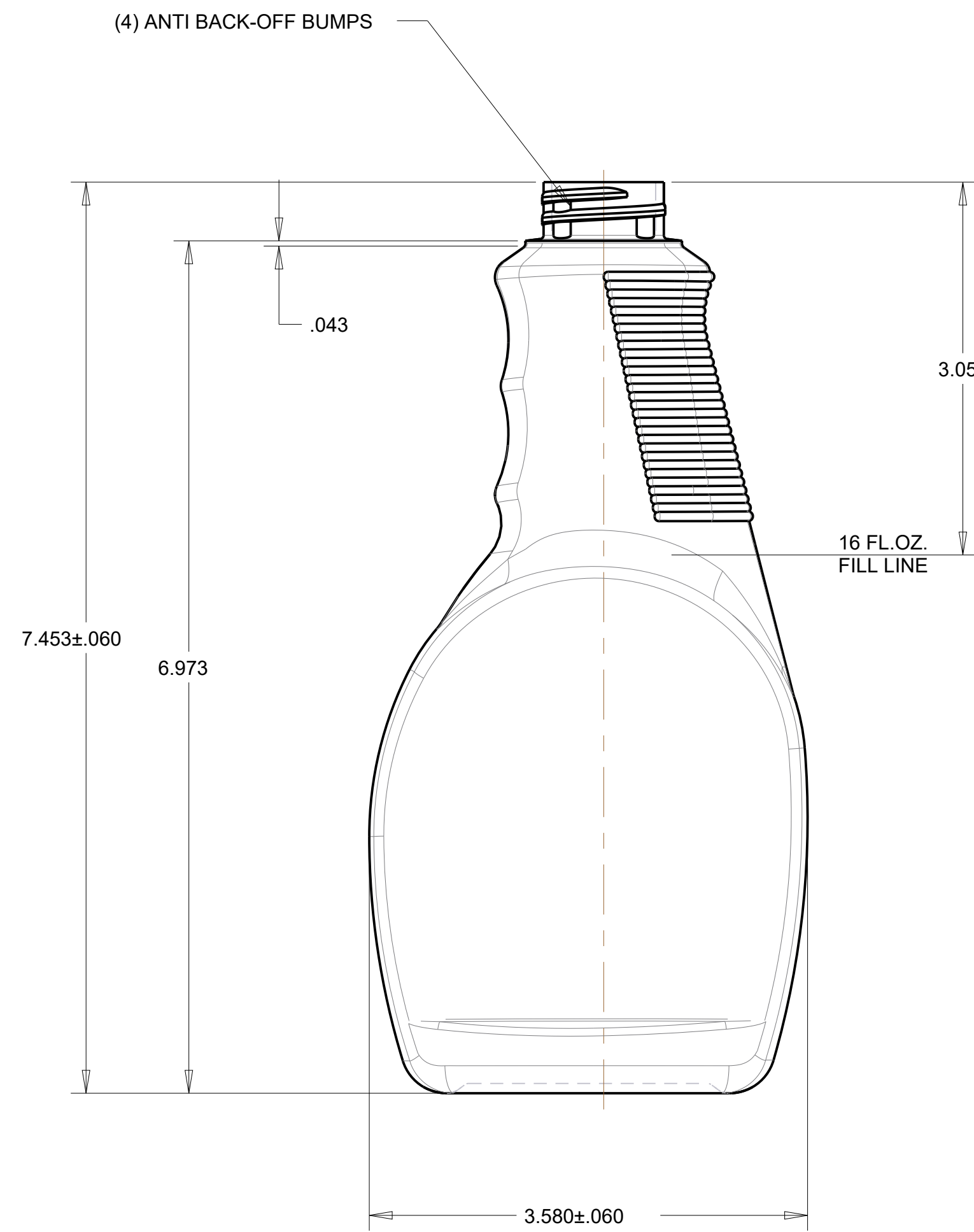
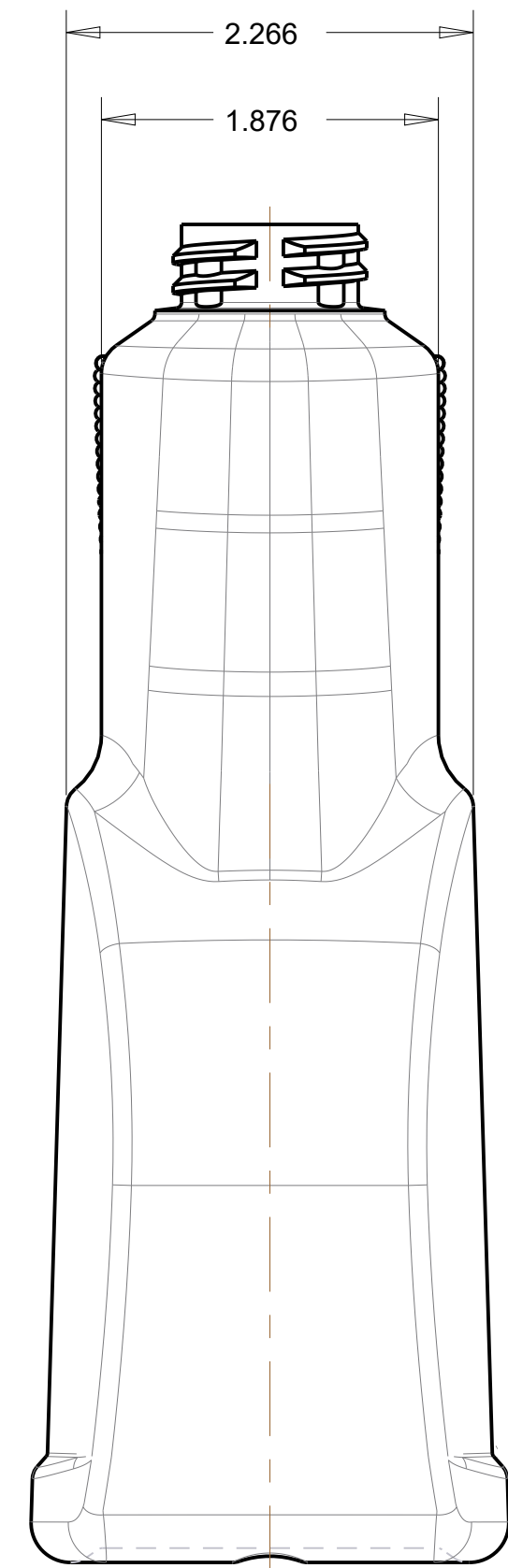
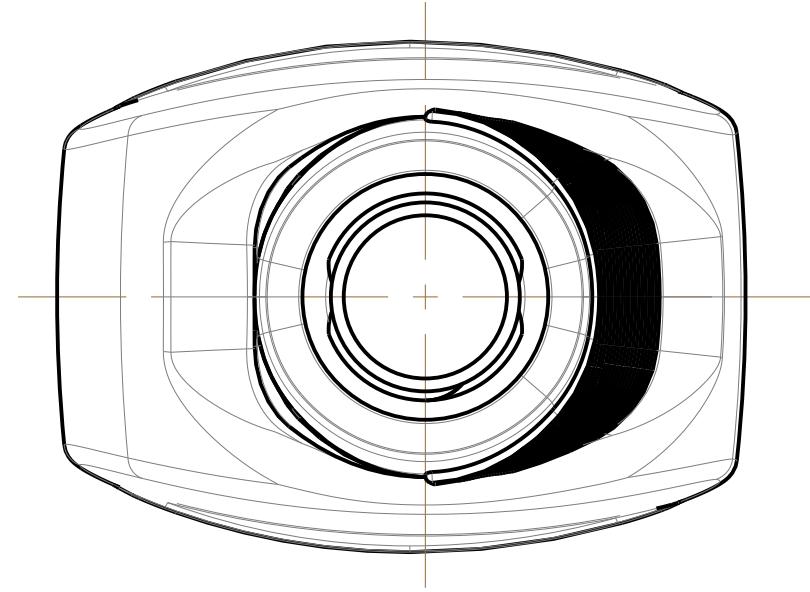

TOLERANCES (EXCEPT AS NOTED)				
DECIMAL	MATERIAL	SCALE	DRAWN BY	
	HDPE	FULL	KSN	
FRACTIONAL	TITLE	APPROVED BY		MOLD NO.
	16OZ SPRAYER			
ANGULAR	DATE	DRAWING NUMBER	REVISION	
	2/1/21	SS-1587-OS		