

NECK FINISH	BOTTLE WEIGHT ±5 GRAMS	OVERFLOW CAPACITY ±30 CC	"T" DIA.	"E" DIA.	"H" DIM.	"S" DIM.	"I" DIA.
110-400	110.0	2322.0	4.331 4.296	4.211 4.176	.612 .582	.050 .020	3.737 MIN.

DATE	SYM	REVISION	BY
6/10/13	A	REVISED RECTANGULAR PATTERN	KSN
6/13/13	B	ADDED IDENTITY NO.	KSN

NOTES:

- OVERFLOW CAPACITY IS BEFORE DECO
- 1-1/4 FULL TURNS OF THREAD
- 5 THREADS PER INCH PITCH
- THREAD START ORIENTED FOR CLOSURE AS SHOWN

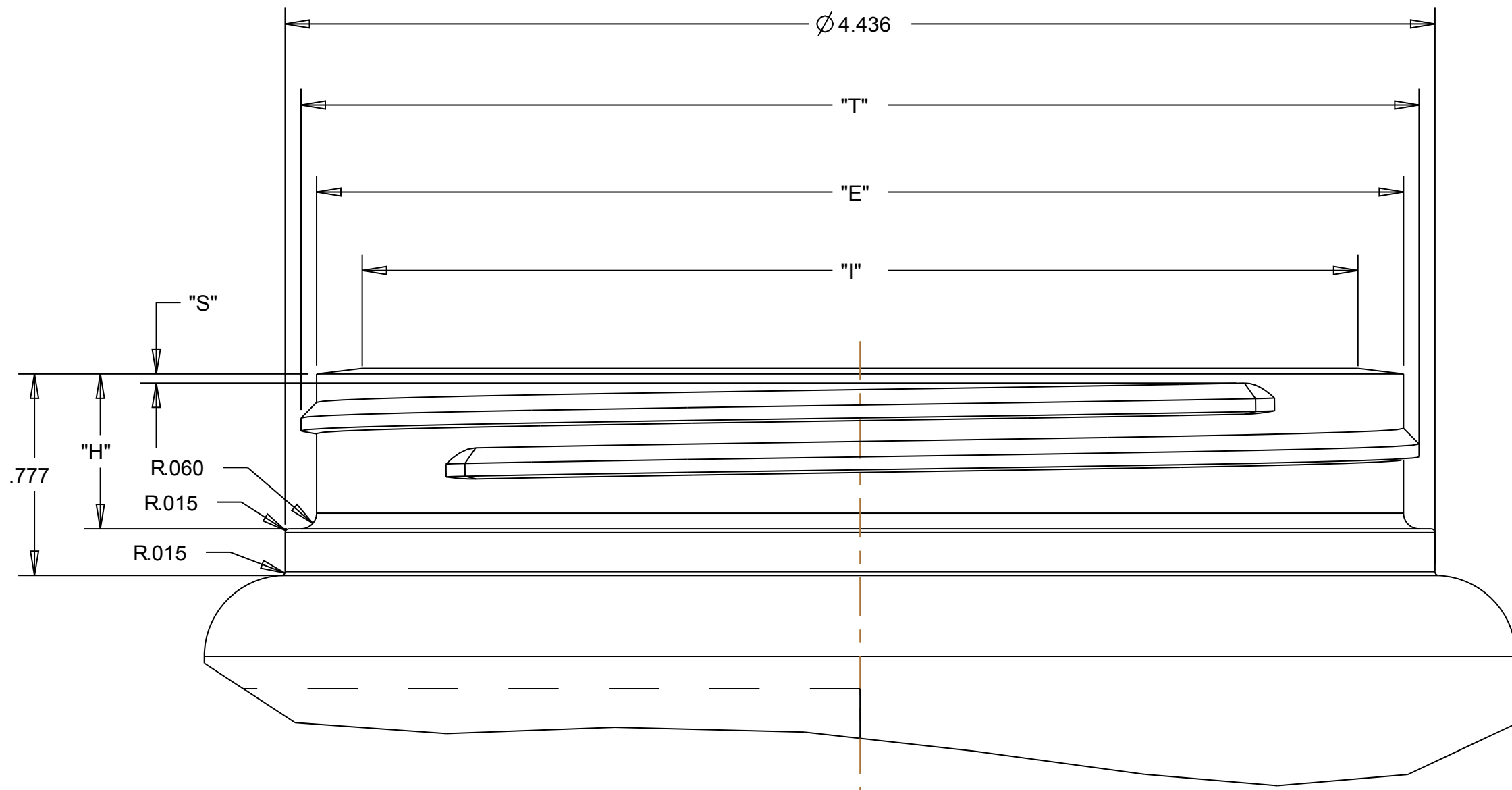

DETAIL A  
SCALE 2.000

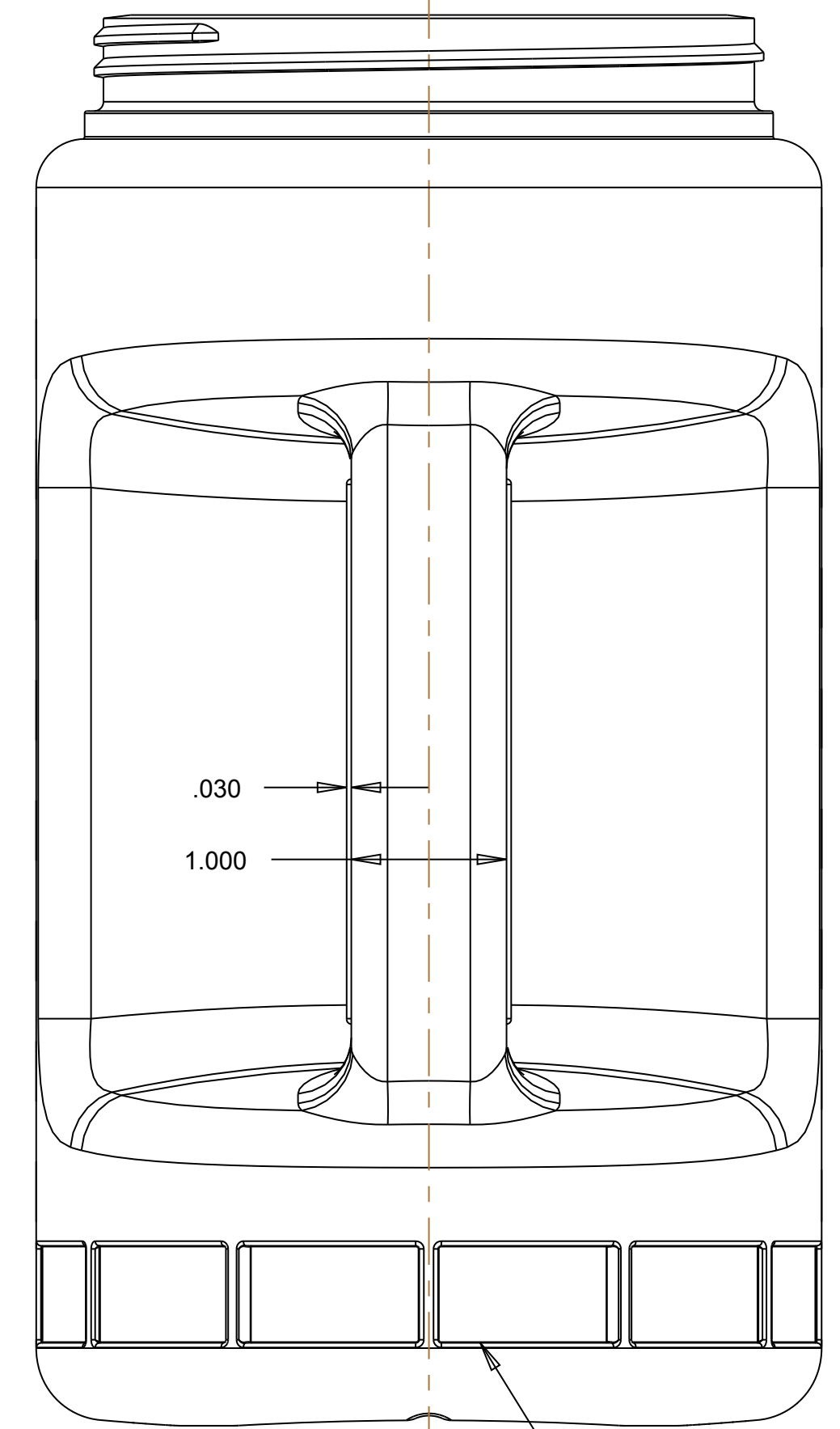
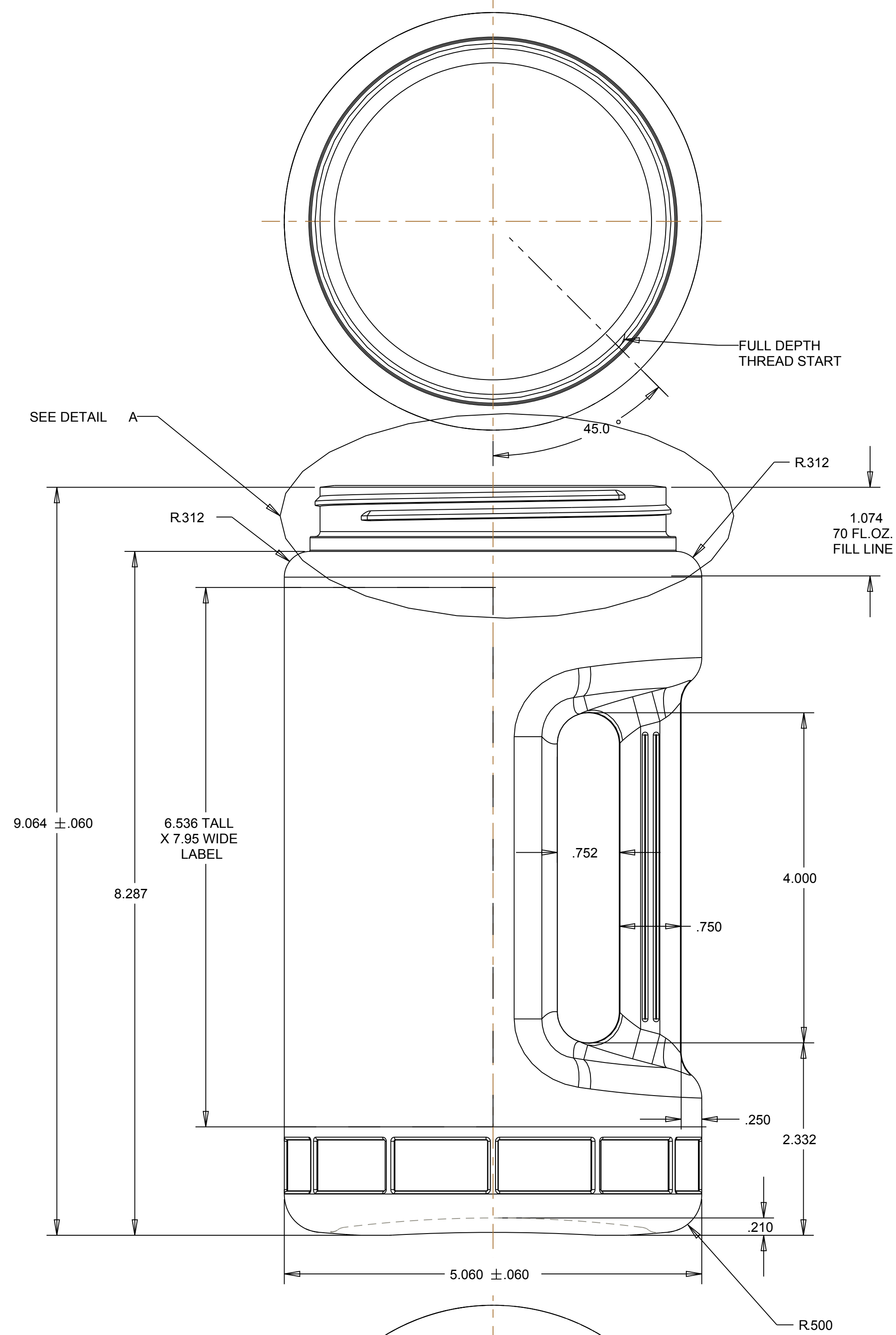
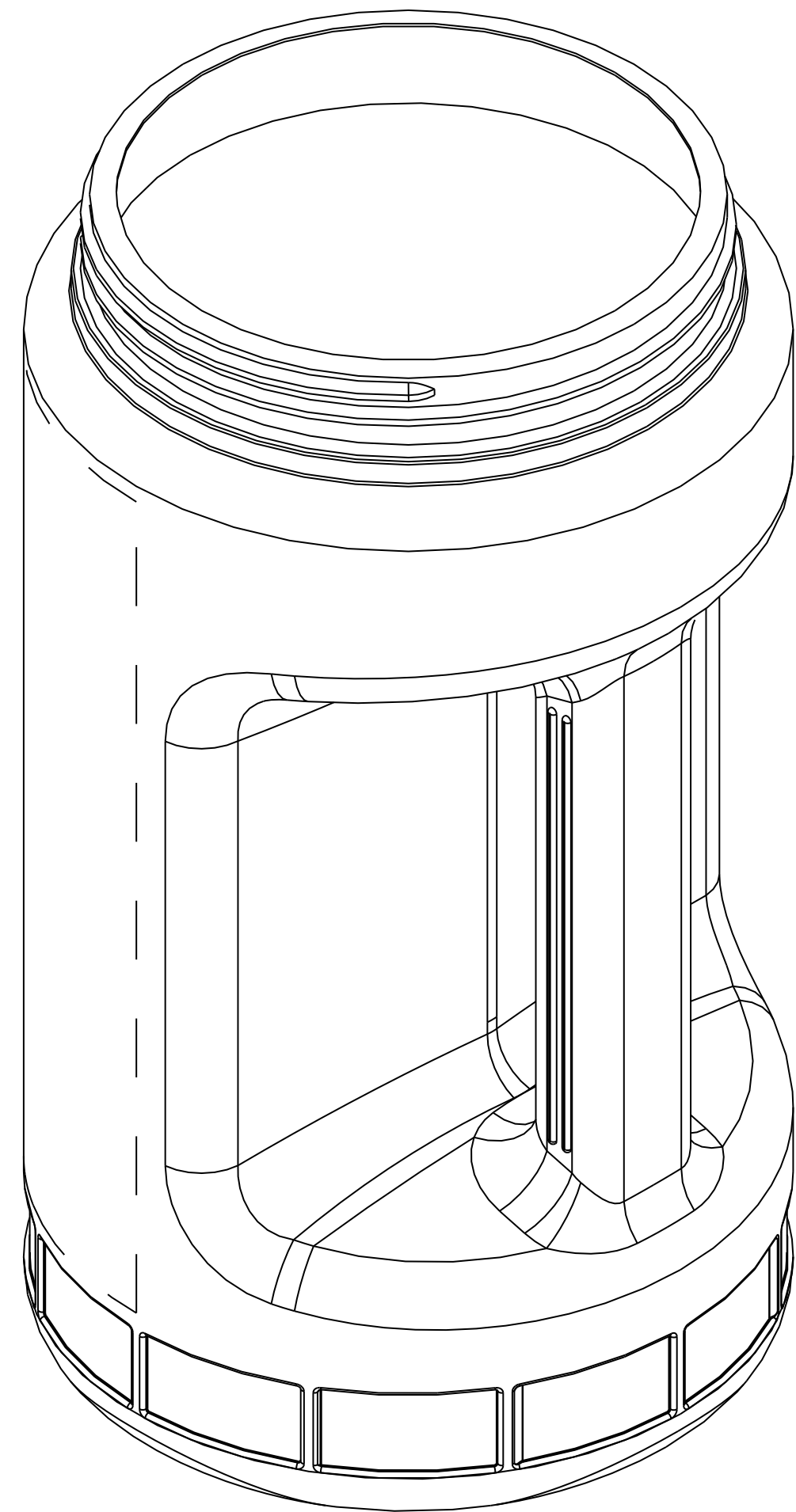

(12) RECTANGULAR PATTERN  
.040 DEEP EQUALLY SPACED

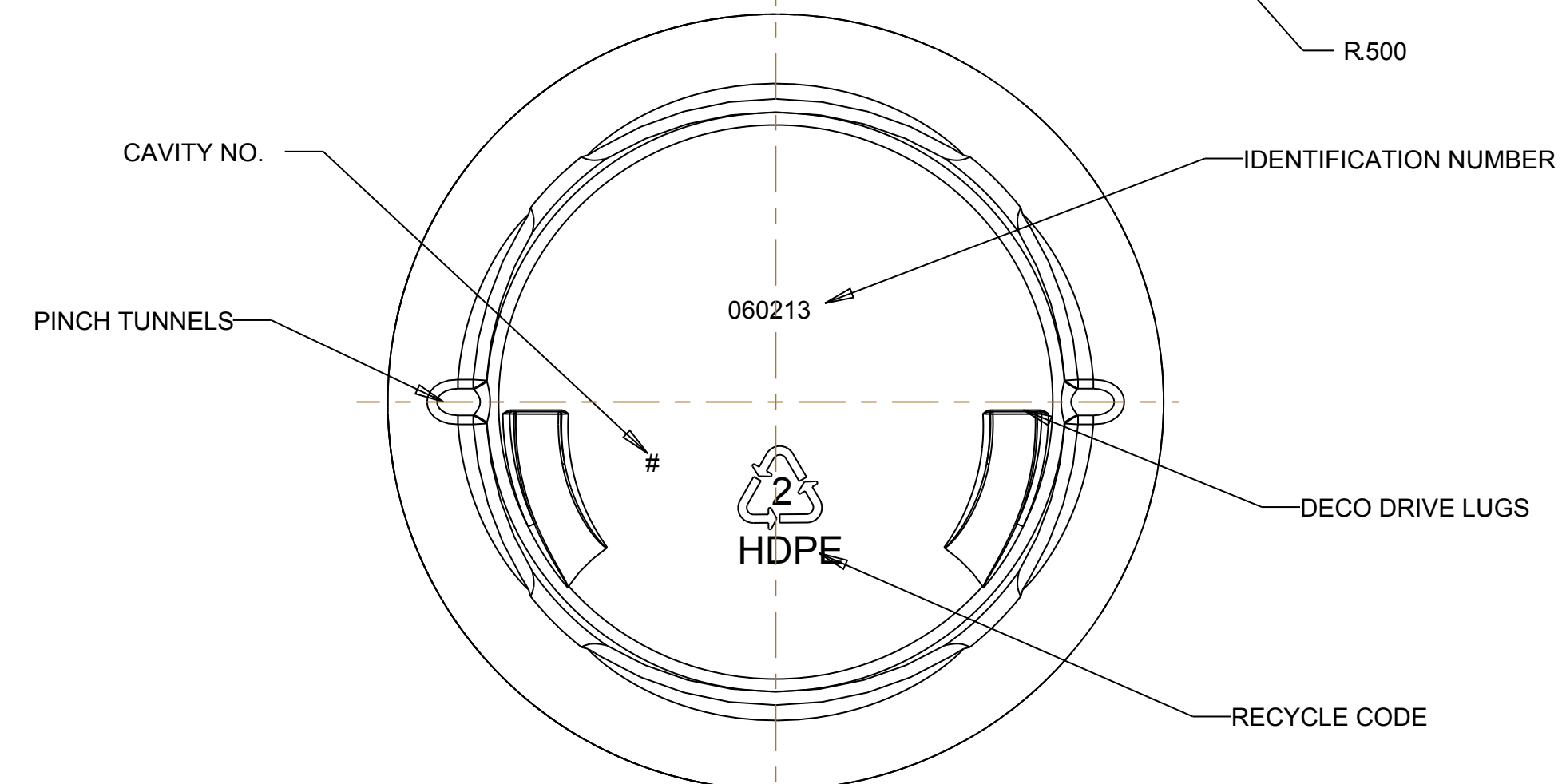

OCEAN STATE PACKAGING EXTRUSION AND INJECTION BLOW MOLDED BOTTLES			
TOL	TITLE		
S.P.I.	70 OZ HANDLED CANISTER		
DATE	DRAWING NO.	REV	
6/9/13	SS-1226-OS	B	