

NECK FINISH	BOTTLE WEIGHT (± 1.5 GR)	OVERFLOW CAPACITY (± 24 CC)	"T" DIA	"E" DIA	"H" DIM	"S" DIM	"I" DIA
38-400	70.8	1528.8	1.476 1.452	1.382 1.358	.459 .429	.061 .031	.987 MIN.

6 THREADS PER INCH PITCH
ONE FULL TURN OF THREAD
M STYLE THREAD

DATE	SYM	REVISION RECORD	AUTH	DR	CK
4/18/19	A	ADDED NOTES 1 & 2. "H" WAS .451/.421			KSN
4/25/19	B	9.940 OH WAS 9.900, 2.978 DEPTH WAS 2.957, 1528.8 ML OFC WAS 1308.5 ML, ADJUSTED FILL LINE			KSN

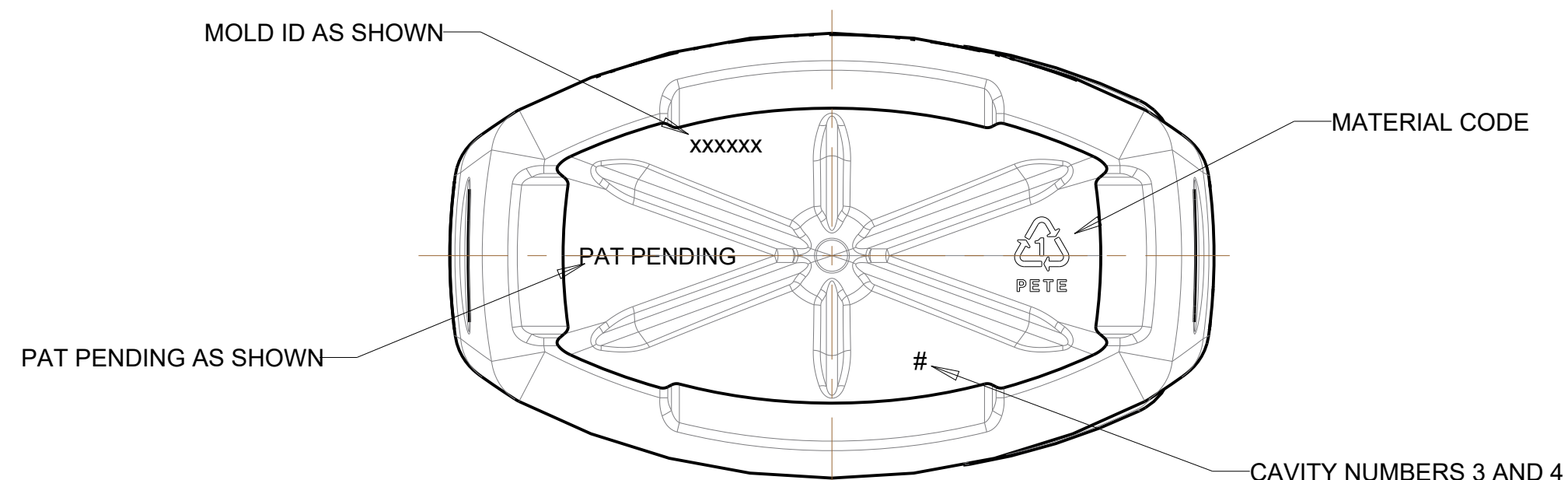
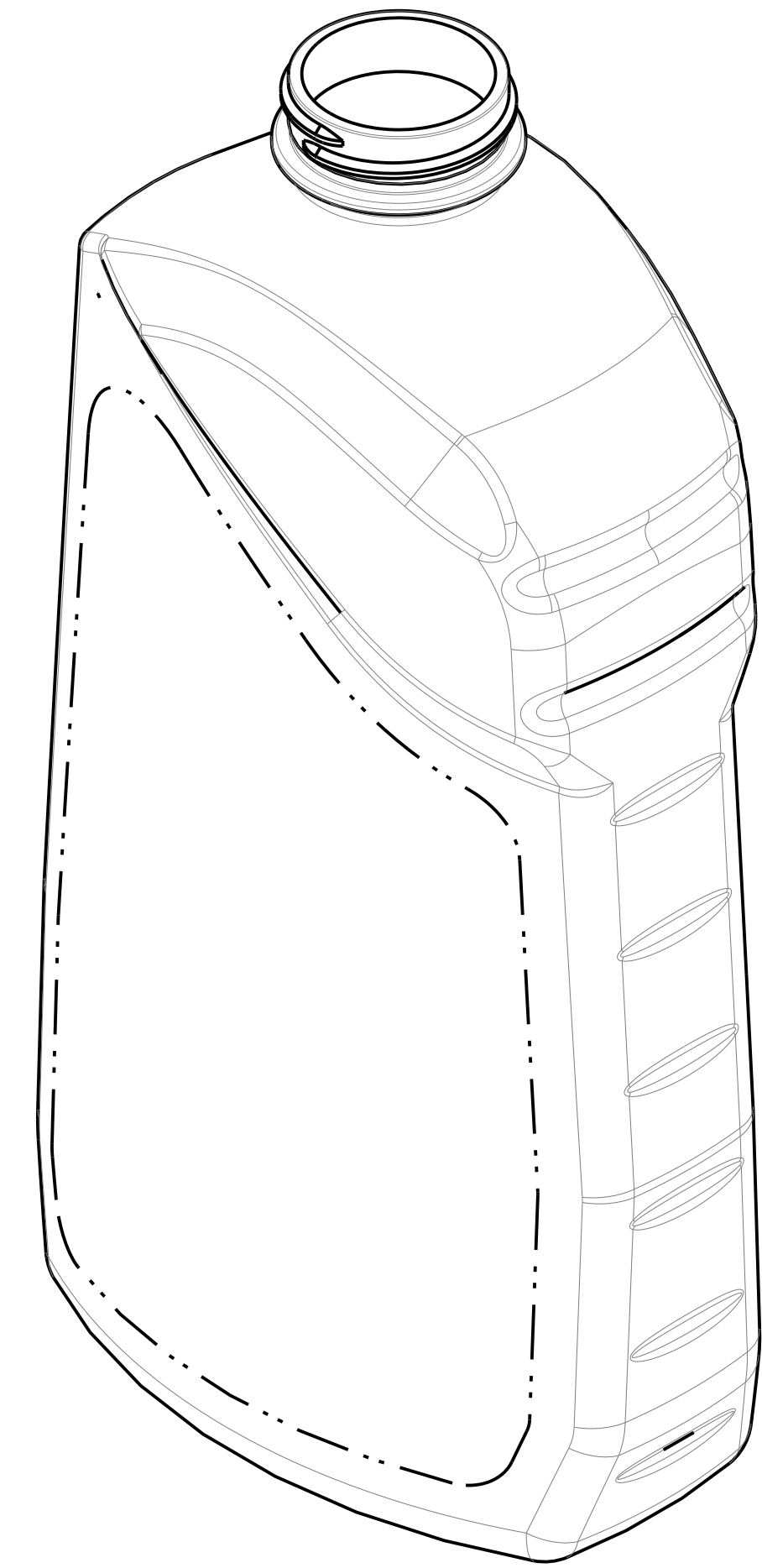
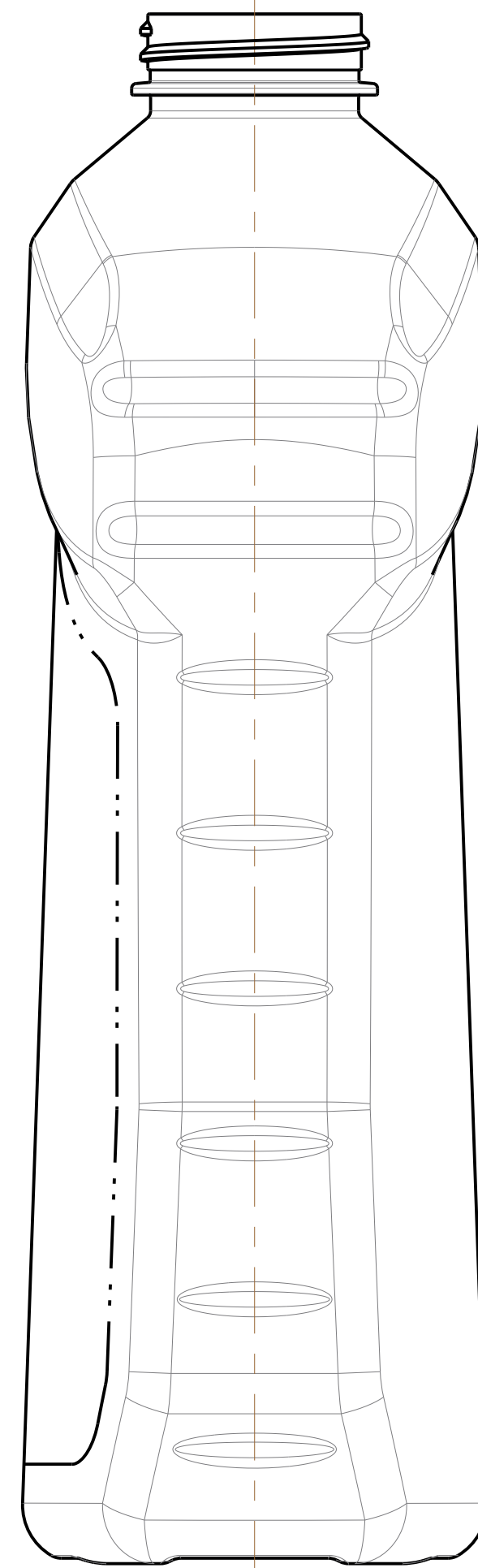
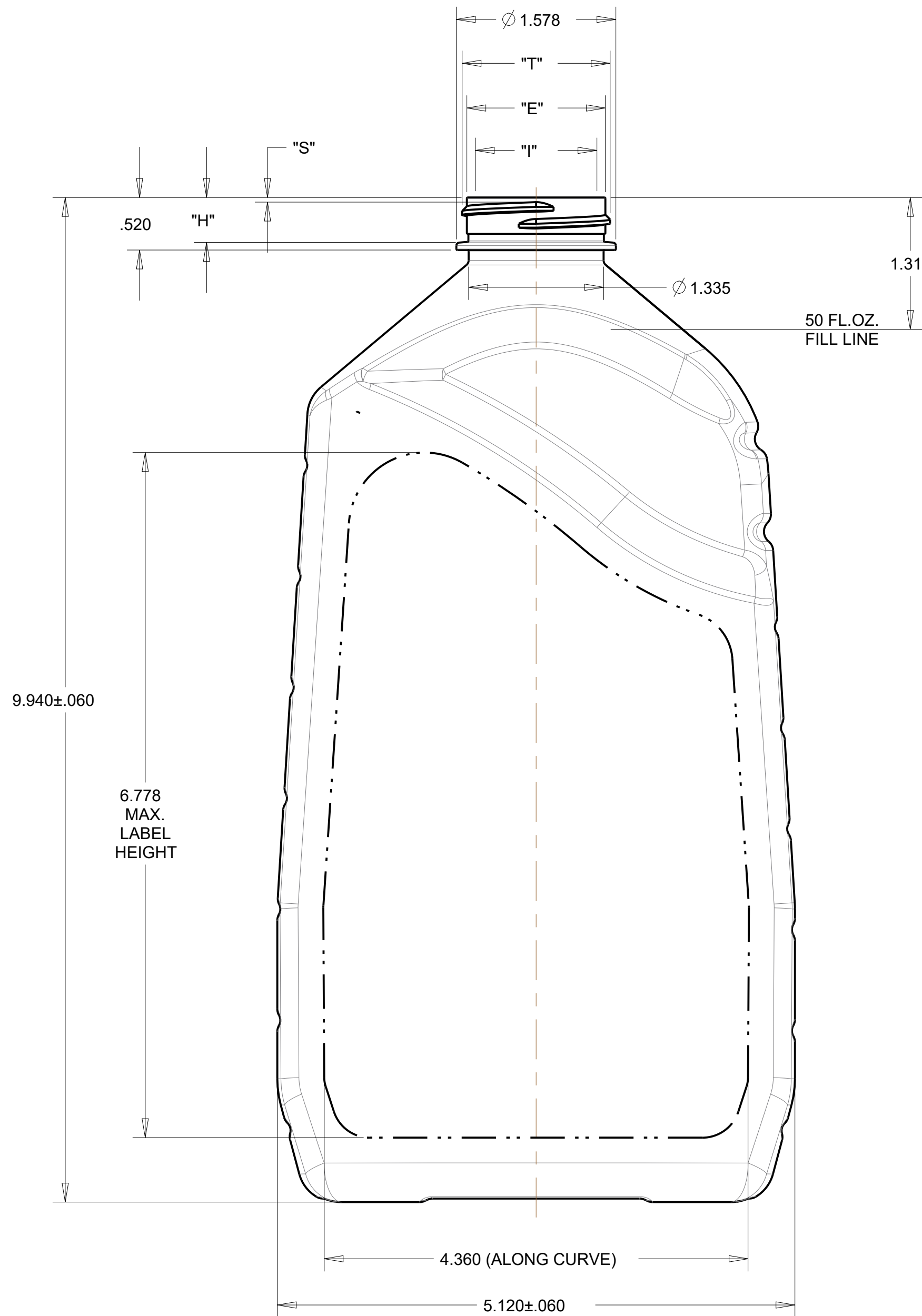
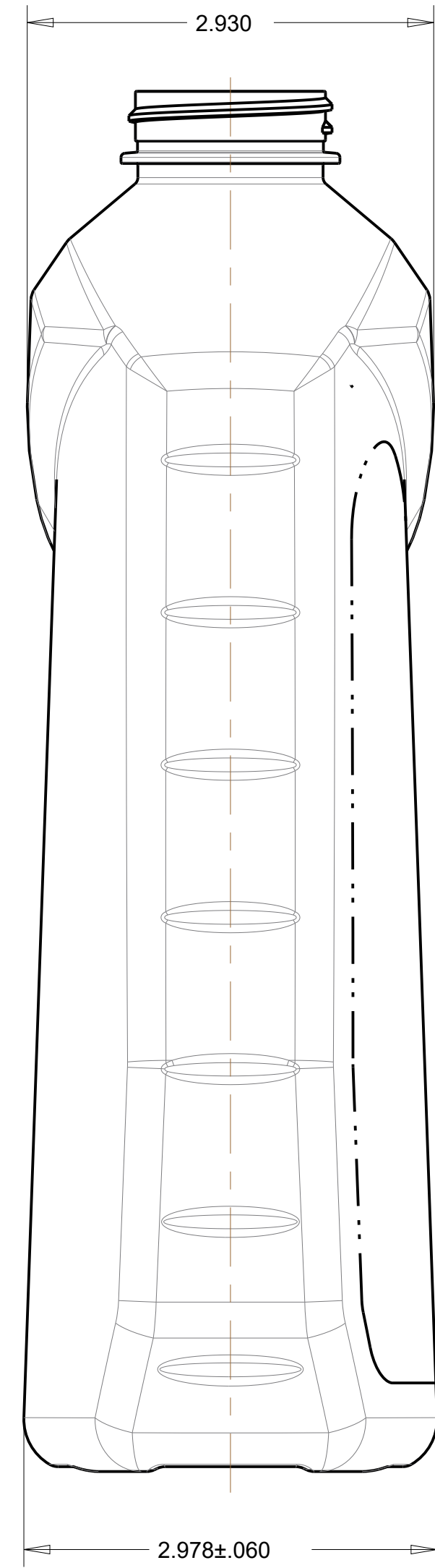

NOTES:

- BOTTLE HALF LENGTH- 12.345"
- MAXIMUM BOTTLE WIDTH- 5.156"

OCEAN STATE PACKAGING EXTRUSION AND INJECTION BLOW MOLDED BOTTLES				
TOLERANCES (EXCEPT AS NOTED)	MATERIAL	SCALE	DRAWN BY	APPROVED BY
	PETE	FULL	KSN	
FRACTIONAL	TITLE	DRAWING NUMBER	REVISION	MOLD NO.
	50 OZ. EZ GRIP OBLONG	SS-1490-OS	B	
ANGULAR	DATE			
	4/17/19			