

NECK FINISH	BOTTLE WEIGHT (± 5 GR)	OVERFLOW CAPACITY (± 38 CC)	"T" DIA	"E" DIA	"H" DIM	"S" DIM	"I" DIA	MATERIAL
110-400	97.0	3036.2	4.331 4.297	4.211 4.177	.612 .582	.075 .045	3.737 MIN	HDPE

DATE	SYM	REVISION RECORD	AUTH	DR	CK

"M" STYLE THREAD
 5 THREADS PER INCH
 PITCH - .200
 ONE FULL TURN OF THREAD

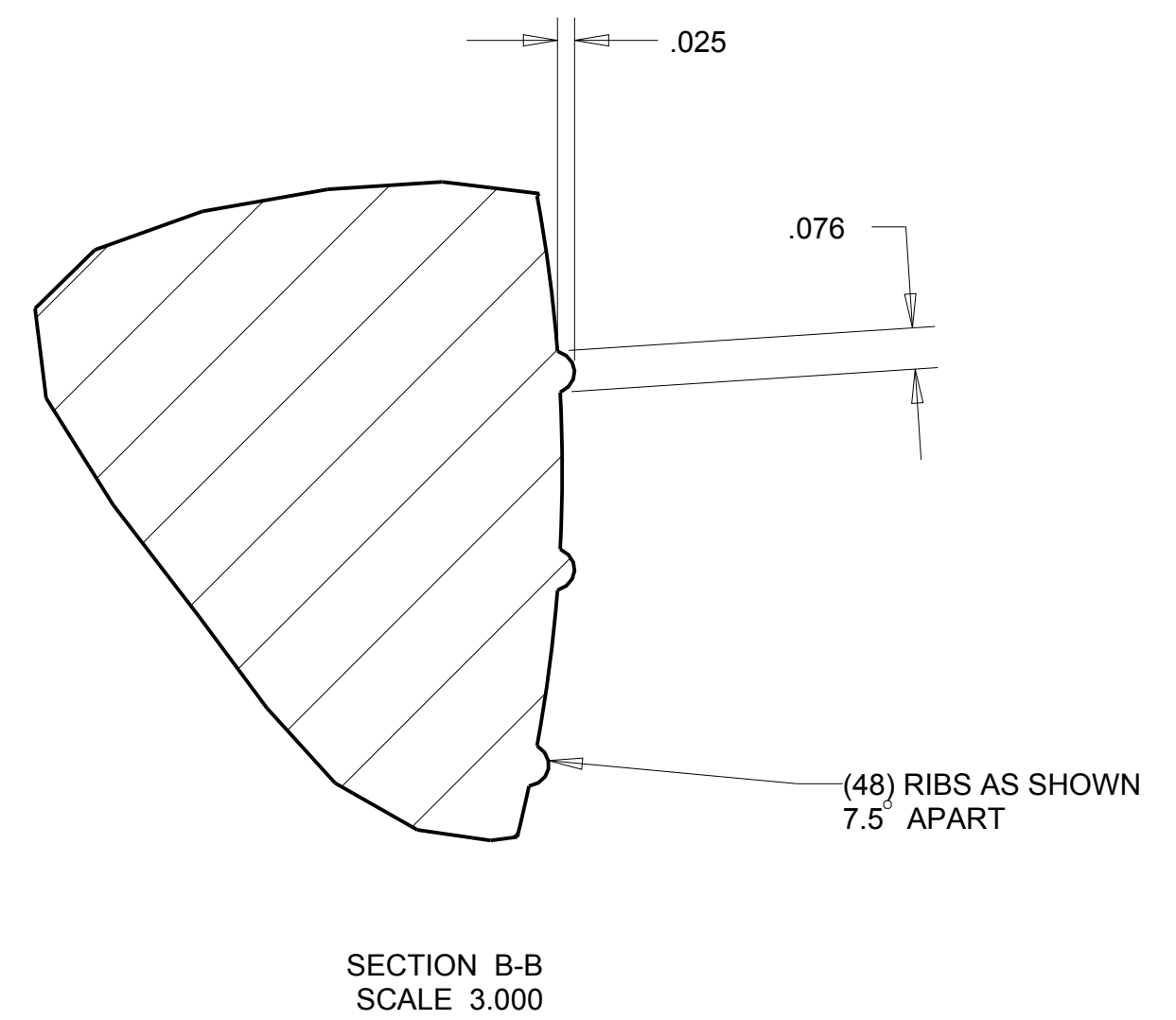
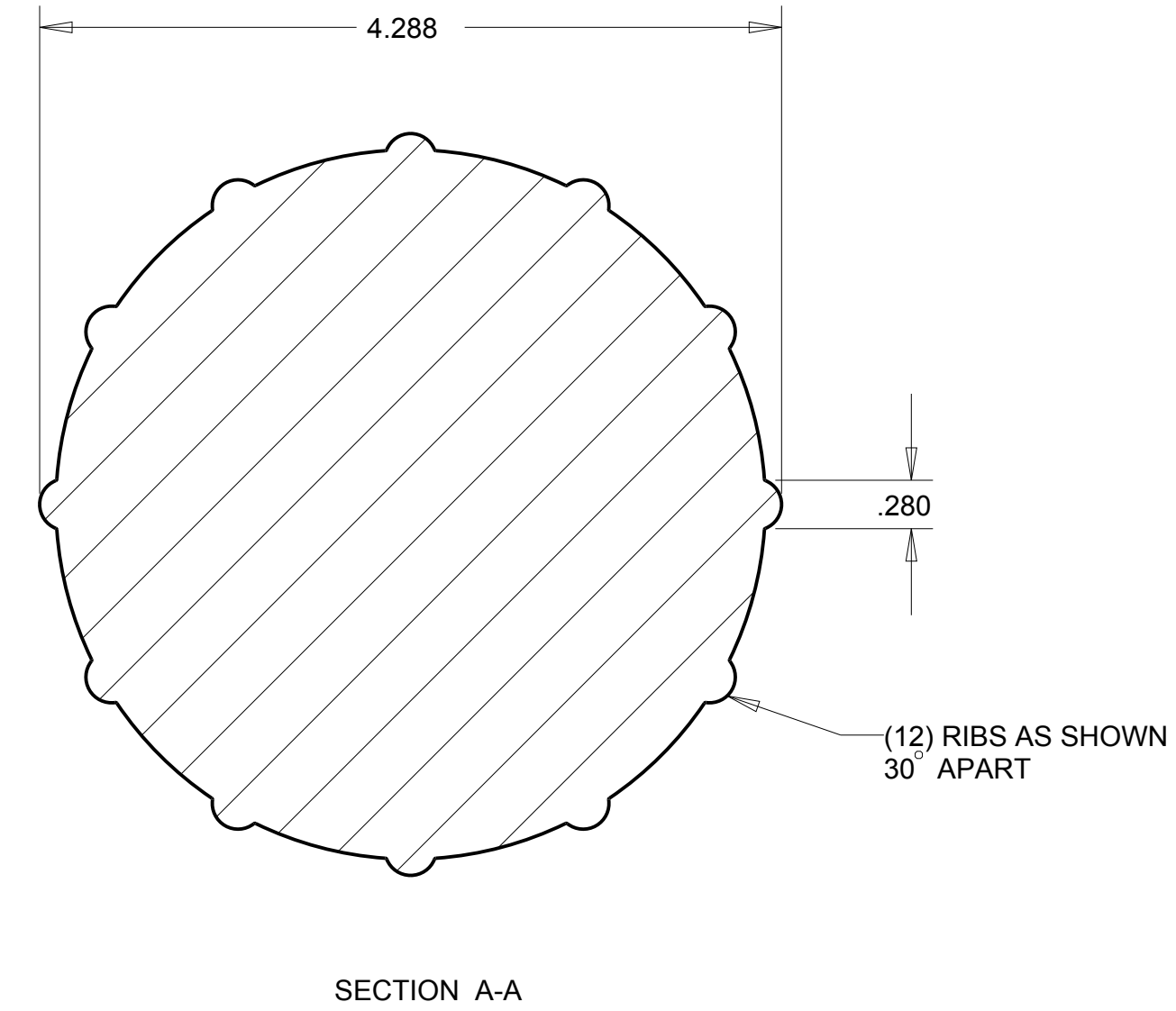
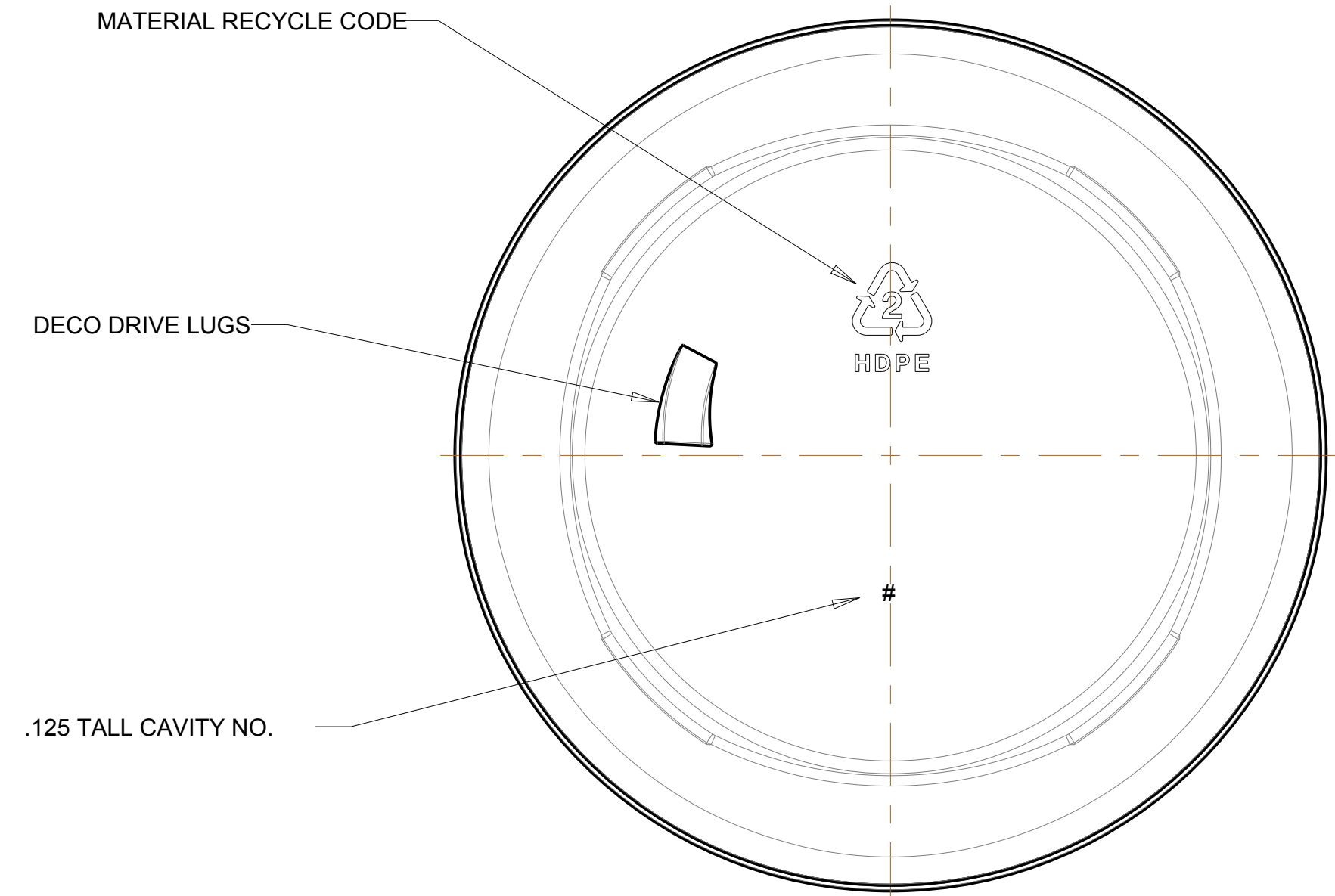
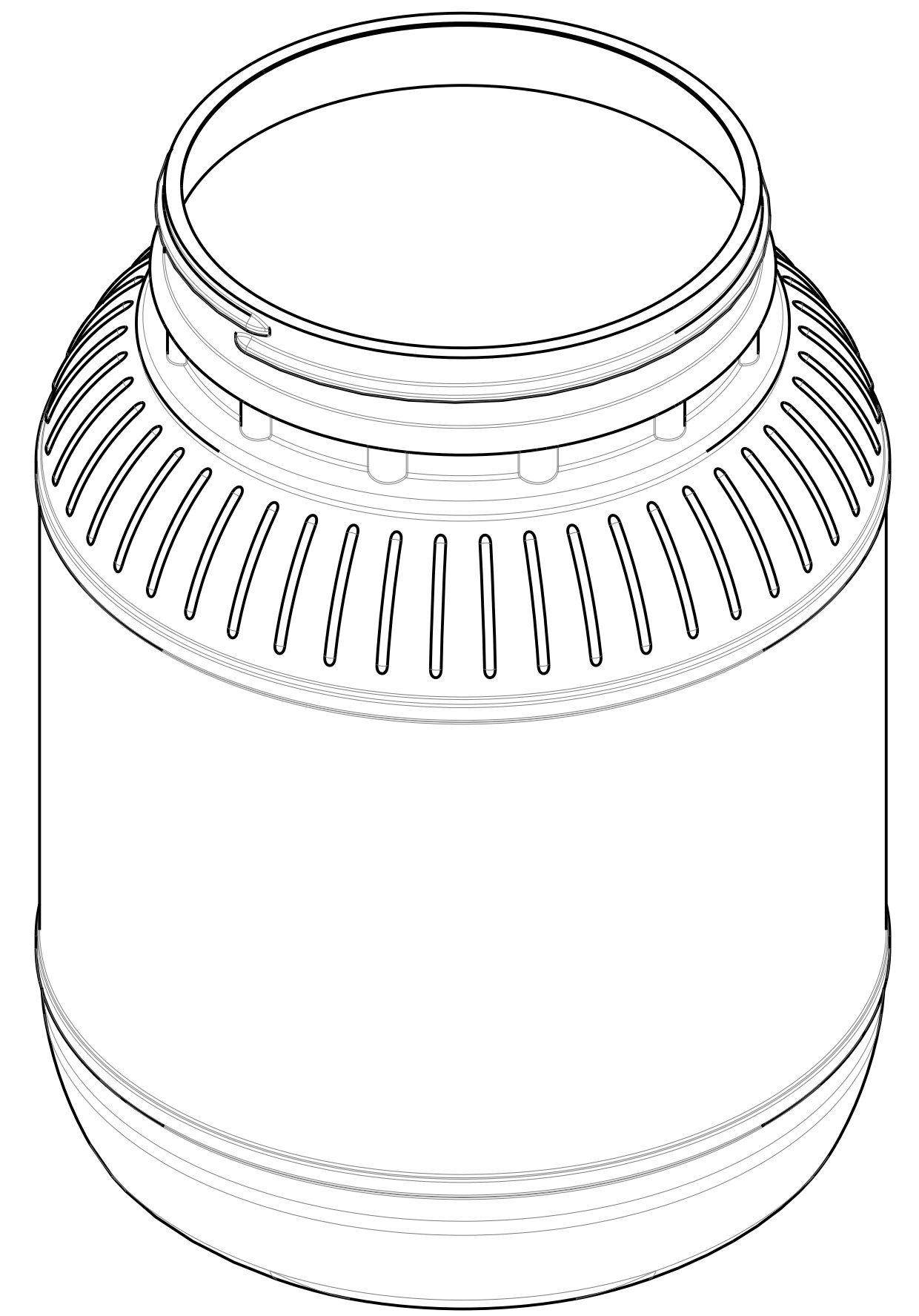
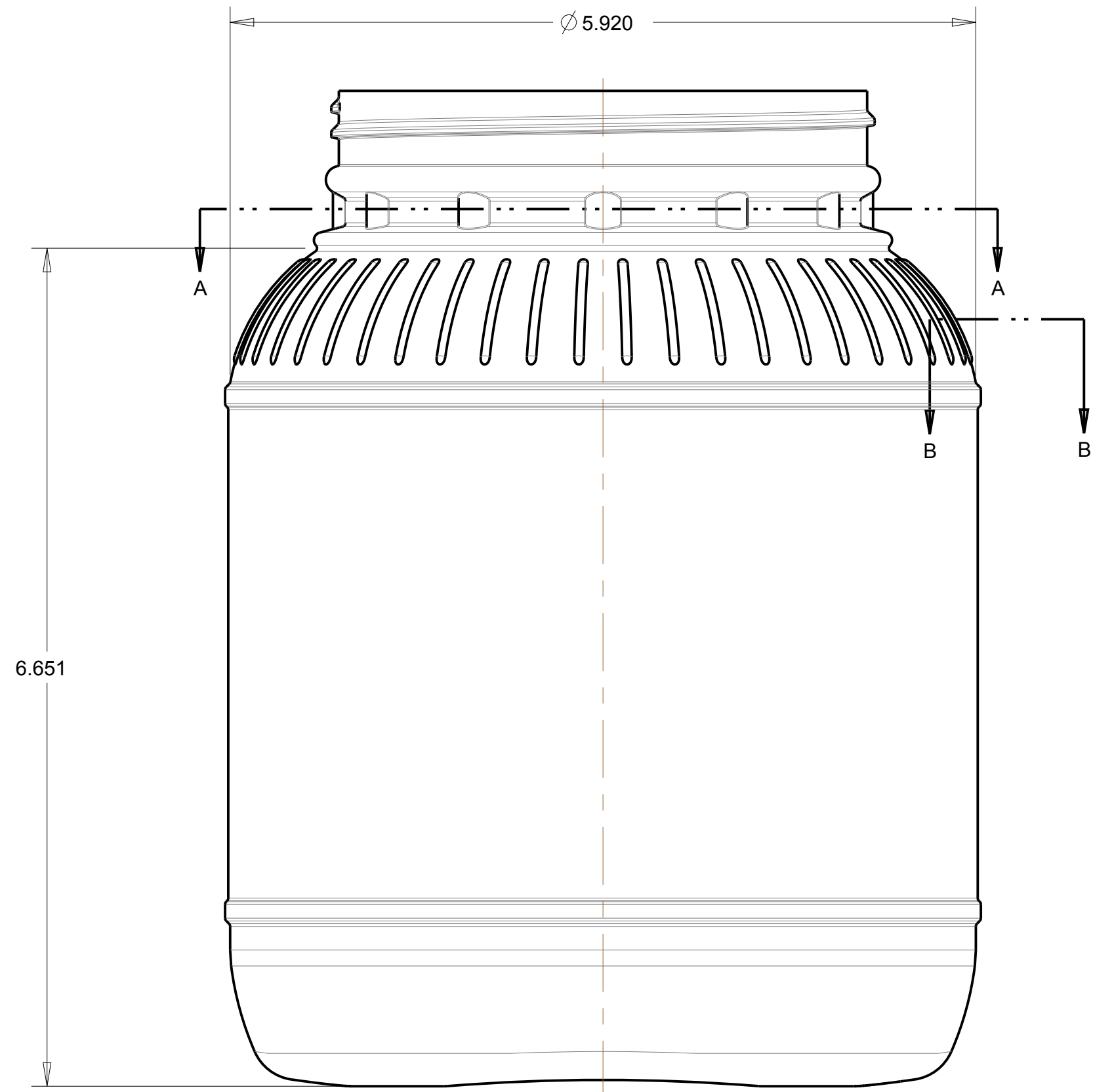
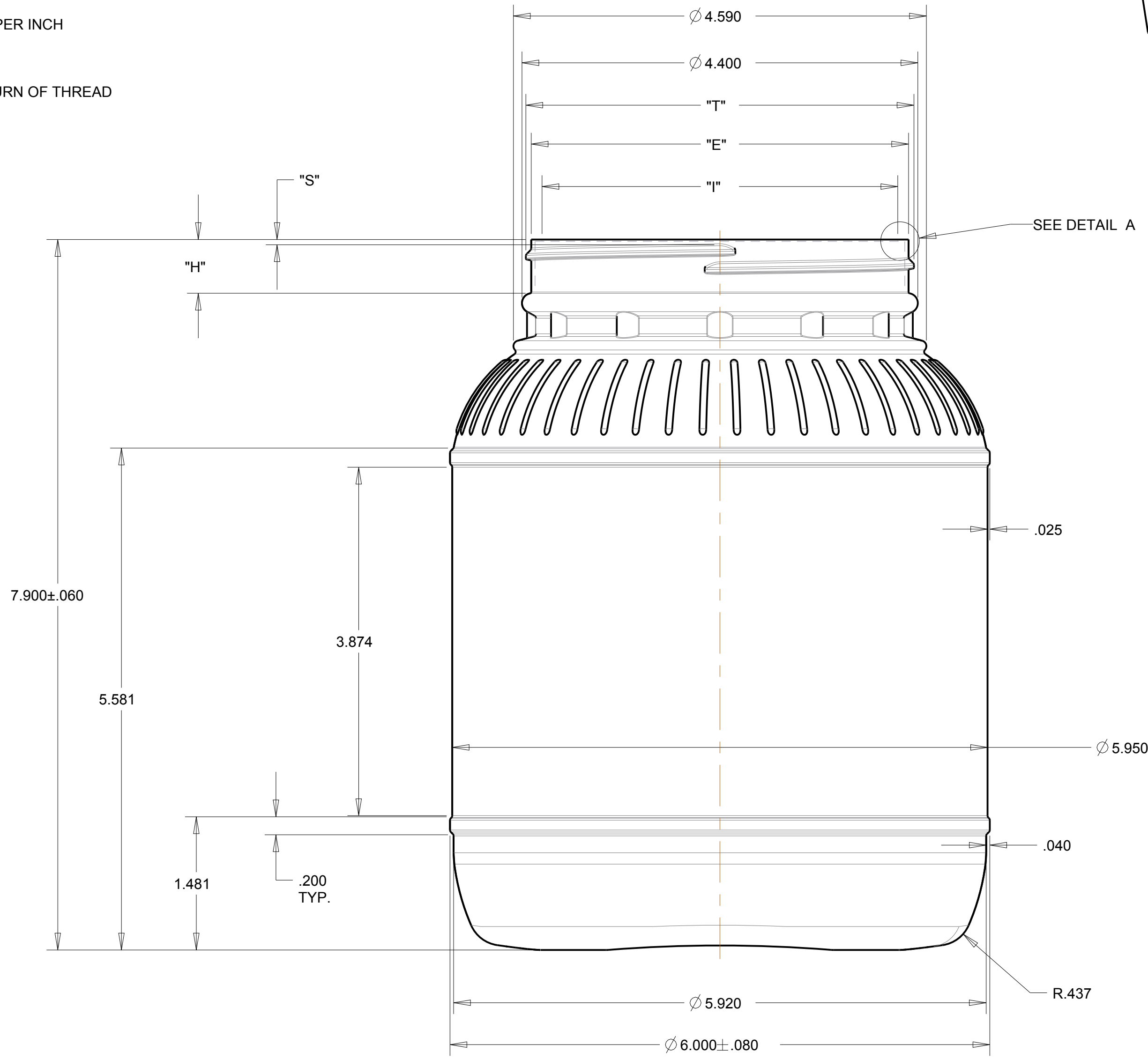
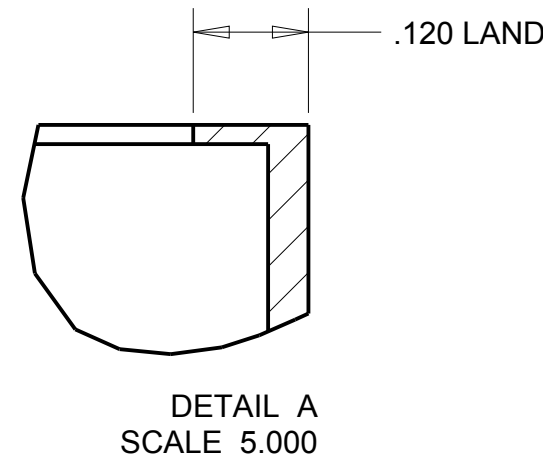

OCEAN STATE PACKAGING EXTRUSION AND INJECTION BLOW MOLDED BOTTLES				
TOLERANCES (EXCEPT AS NOTED)	MATERIAL	SCALE	DRAWN BY	MOLD NO.
DECIMAL	HDPE	FULL	KSN	
FRACTIONAL	TITLE	APPROVED BY		
	96 OZ. BARREL			
ANGULAR	DATE	DRAWING NUMBER	REVISION	
	6/16/15	SS-1333-OS		