

| DATE | SYM | REVISION RECORD | AUTH | DR | CK |
|------|-----|-----------------|------|----|----|
|      |     |                 |      |    |    |
|      |     |                 |      |    |    |
|      |     |                 |      |    |    |

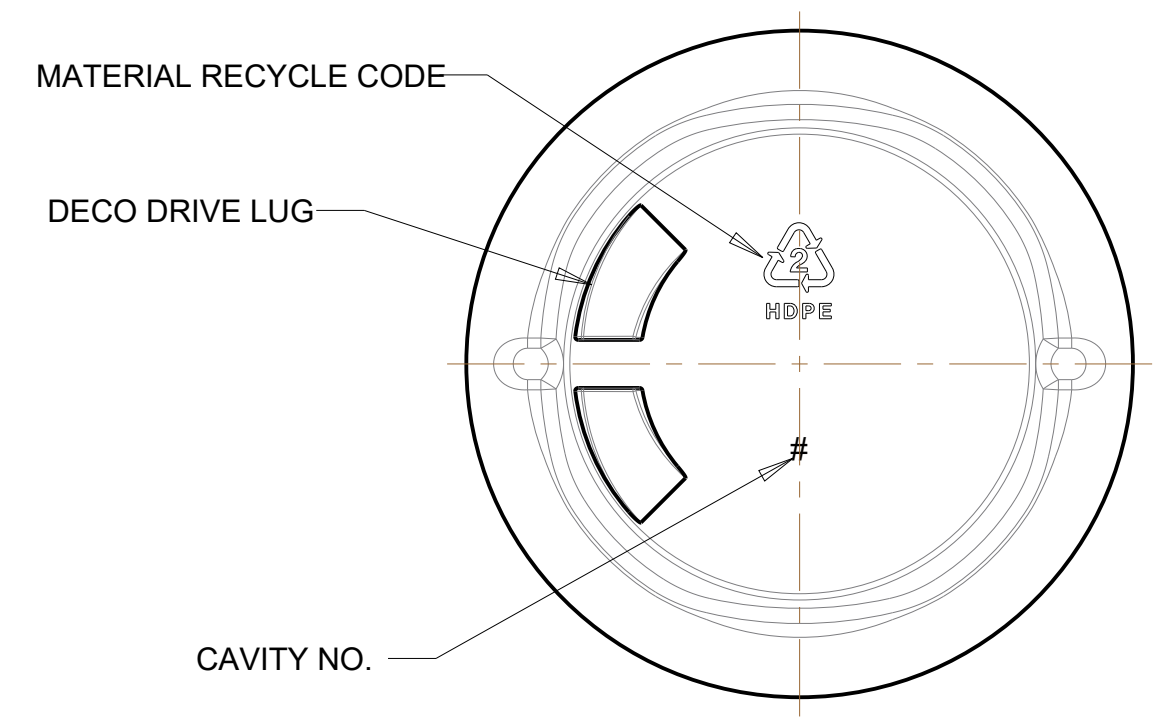
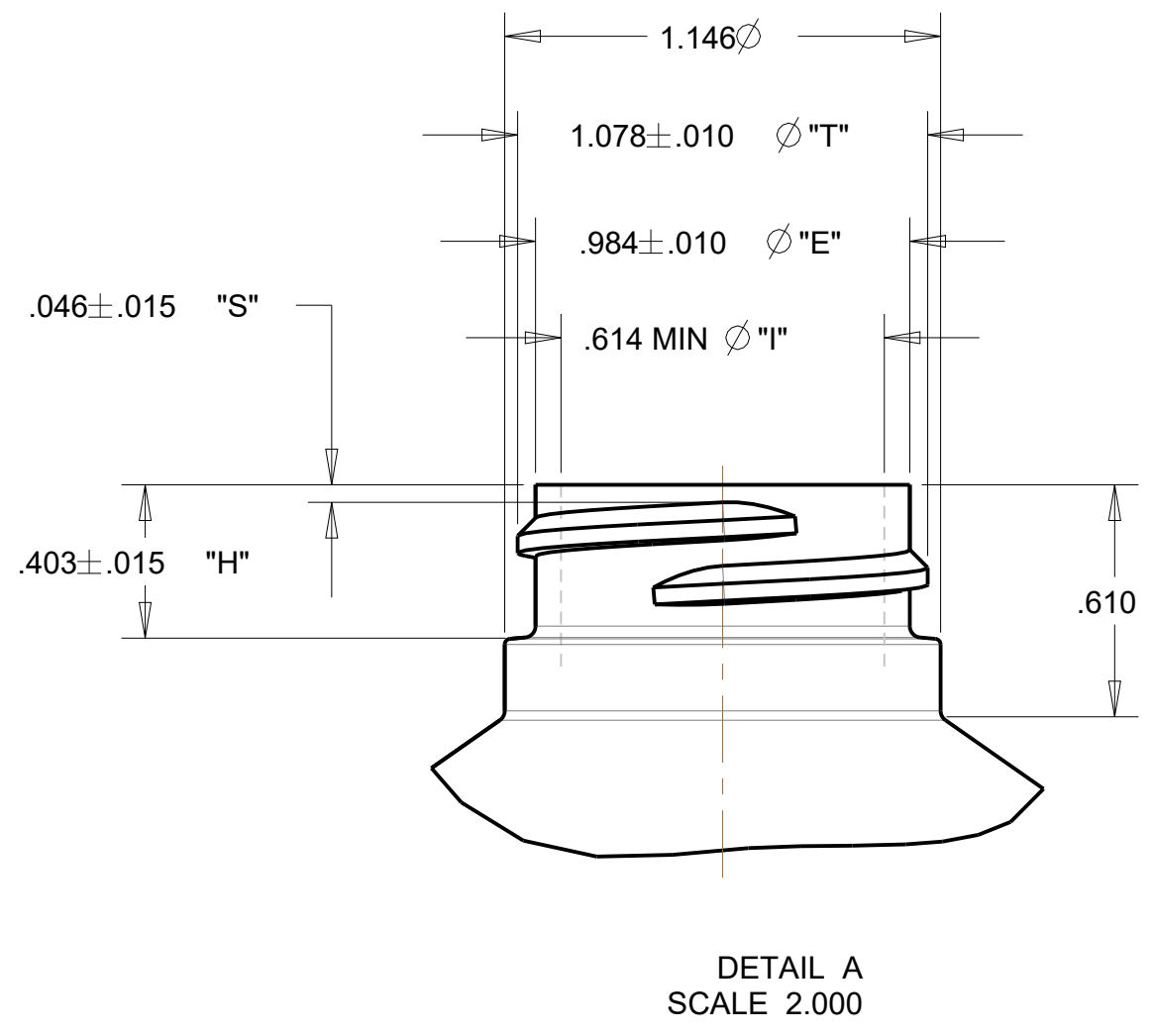
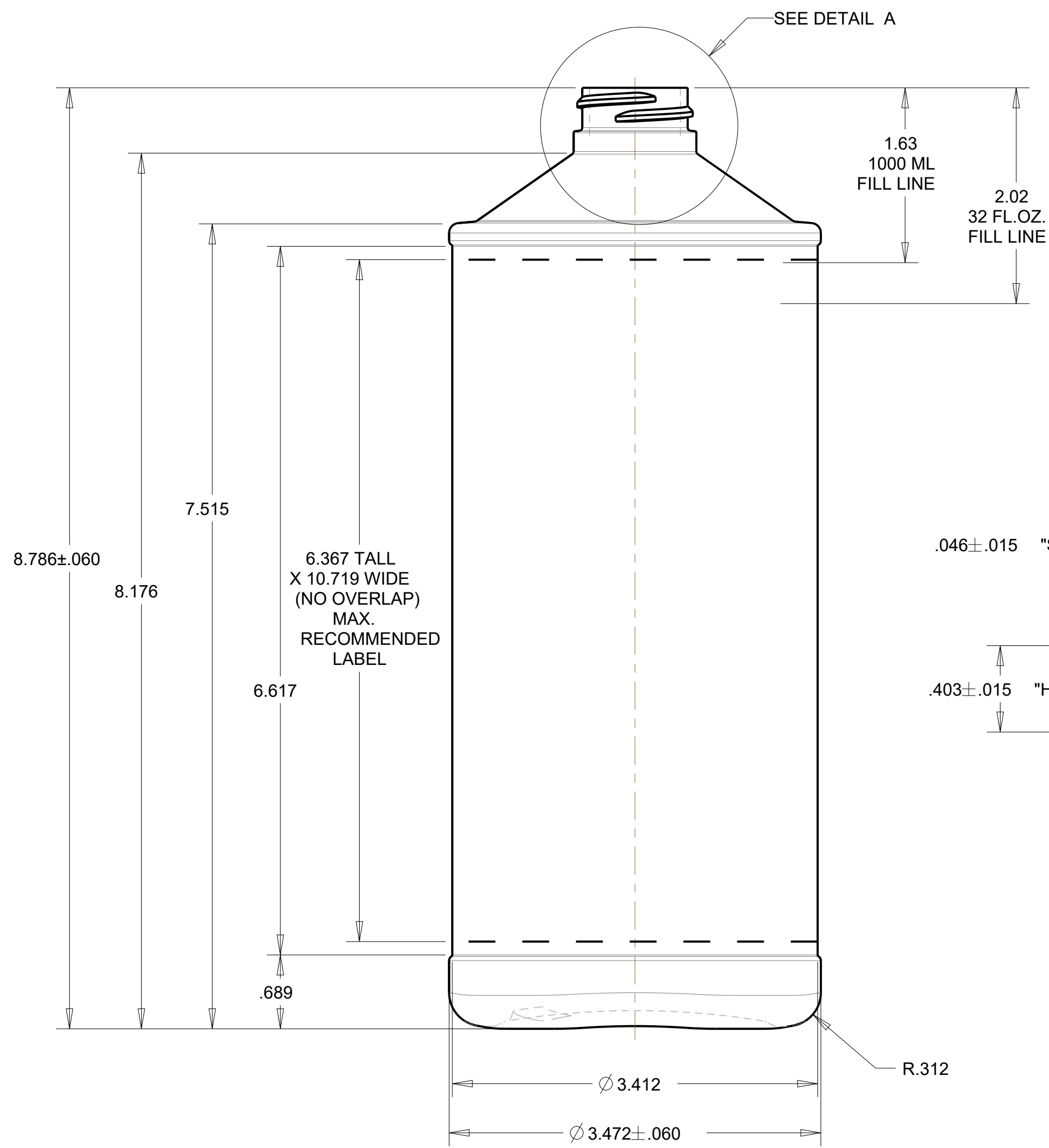

- NOTES:
1. BOTTLE WEIGHT- 68.0 ± 2 GRAMS HDPE
  2. OVERFLOW CAPACITY (BEFORE DECO)- 1093.5 ± 20 CC
  3. NECK FINISH- 28-400  
M STYLE THREAD  
6 THREADS PER INCH  
ONE FULL TURN OF THREAD  
PITCH - .167

| TOLERANCES<br>(EXCEPT AS NOTED) |                      |                |          | OCEAN STATE PACKAGING<br>EXTRUSION AND INJECTION BLOW MOLDED BOTTLES |  |
|---------------------------------|----------------------|----------------|----------|--|--|
| DECIMAL                         | MATERIAL             | SCALE          | DRAWN BY |  |  |
|                                 | HDPE                 | FULL           | KSN      |  |  |
| FRACTIONAL                      | TITLE                |                |          | APPROVED BY  |  |
|                                 | 32 OZ CONE TOP ROUND |                |          | MOLD NO  |  |
| ANGULAR                         | DATE                 | DRAWING NUMBER | REVISION |  |  |
|                                 | 11/9/19              | SS-1525-OS     |          |  |  |