

NECK FINISH	BOTTLE WEIGHT (± 1.5 GR)	OVERFLOW CAPACITY (± 24 CC)	"T" DIA	"E" DIA	"H" DIM	"S" DIM	"I" DIA
38-400	70.8	1519.7	1.476 1.452	1.382 1.358	.459 .429	.061 .031	.987 MIN.

DATE	SYM	REVISION RECORD	AUTH	DR	CK

6 THREADS PER INCH PITCH  
ONE FULL TURN OF THREAD  
M STYLE THREAD

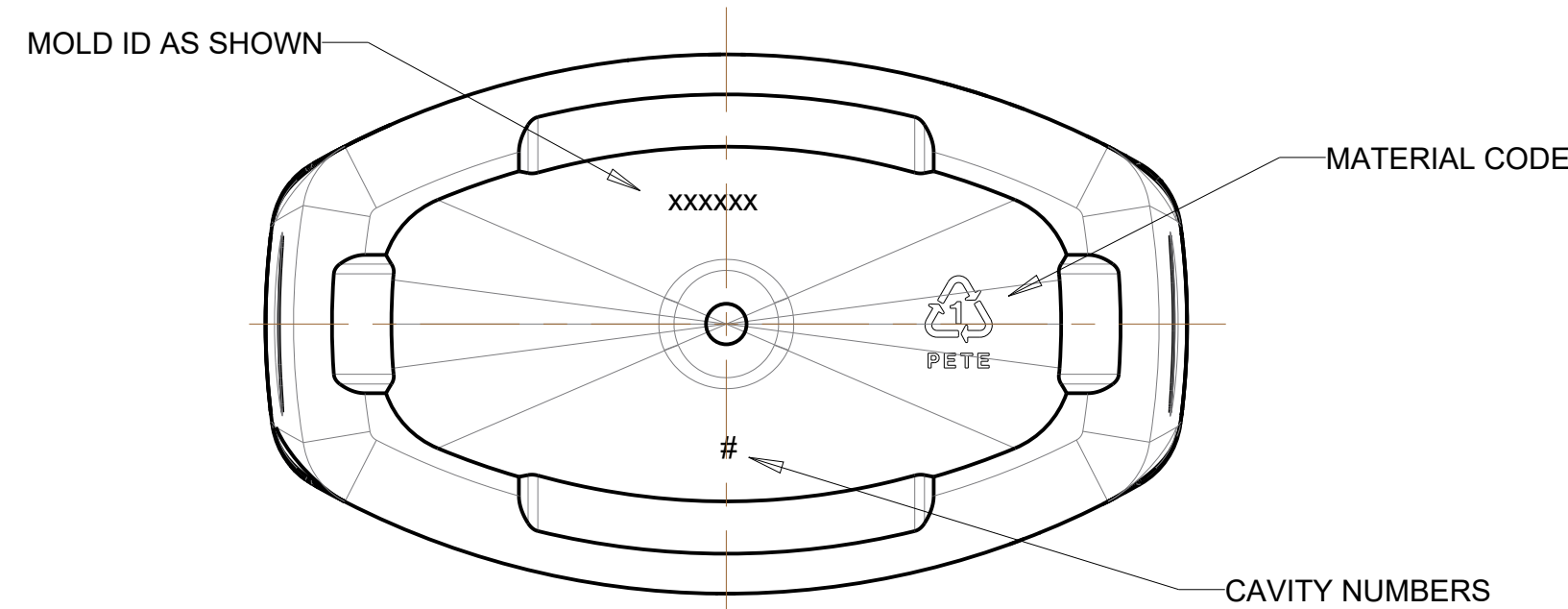
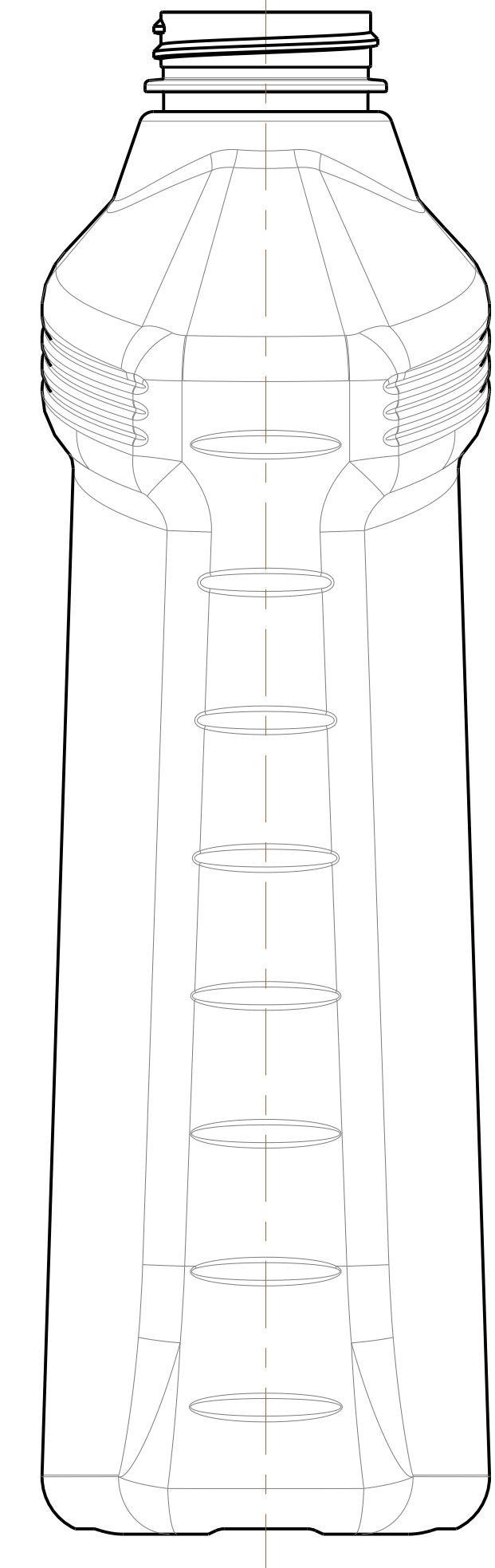
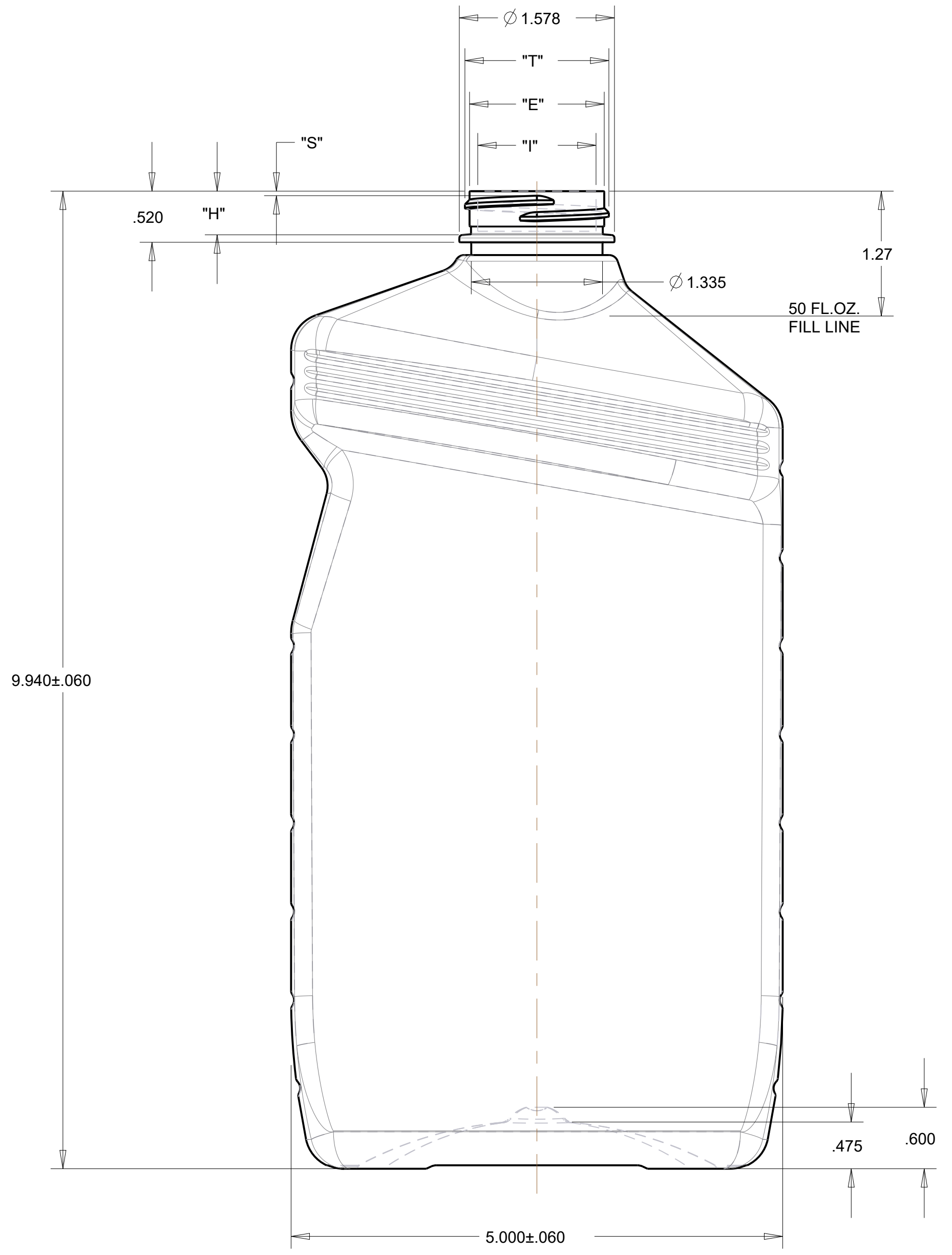
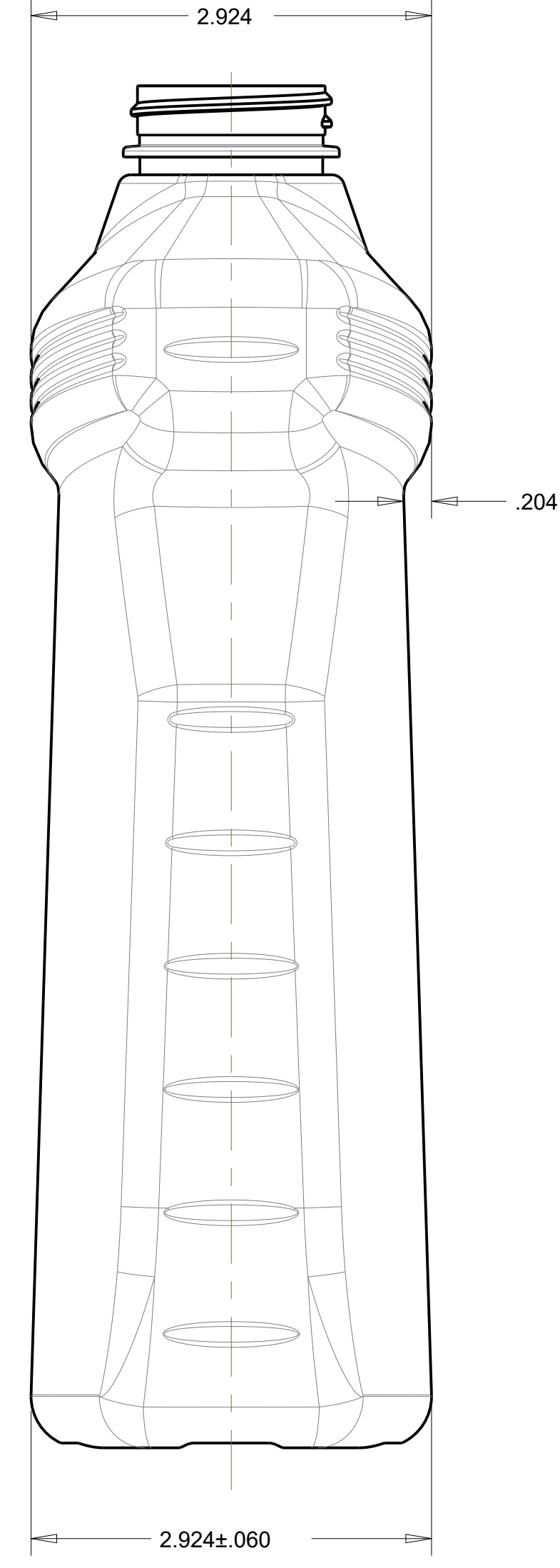
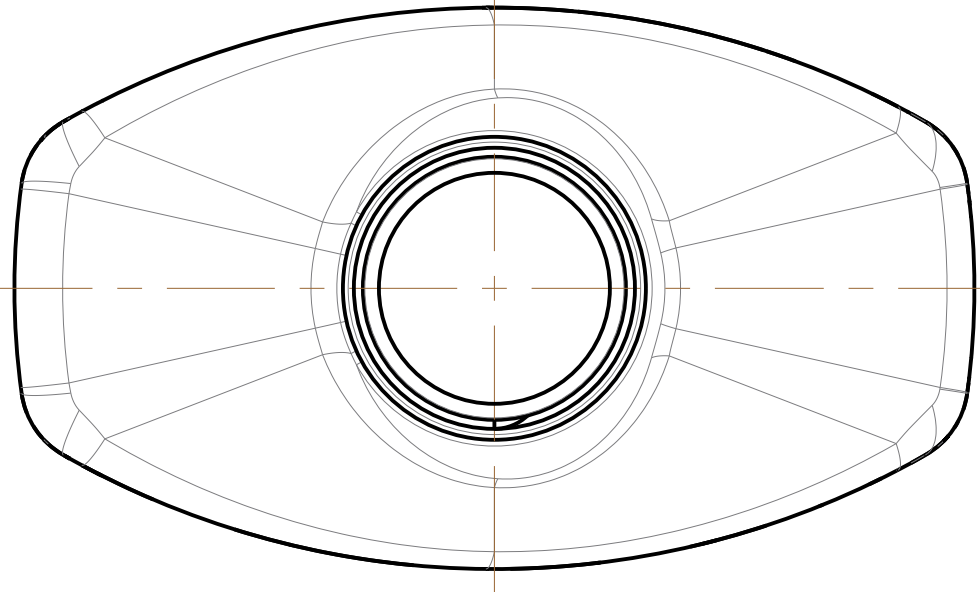

TOLERANCES (EXCEPT AS NOTED)			
DECIMAL	MATERIAL	SCALE	DRAWN BY
	PETE	FULL	KSN
FRACTIONAL	TITLE	APPROVED BY	MOLD NO.
	50 OZ. SLANTED OBLONG-V4		
ANGULAR	DATE	DRAWING NUMBER	REVISION
	12/5/19	SS-1531-OS	

TOLERANCES (EXCEPT AS NOTED)			
DECIMAL	MATERIAL	SCALE	DRAWN BY
			APPROVED BY
FRACTIONAL	TITLE		MOLD NO.
ANGULAR	DATE	DRAWING NUMBER	REVISION