

DATE	SYM	REVISION RECORD	AUTH	DR	CK

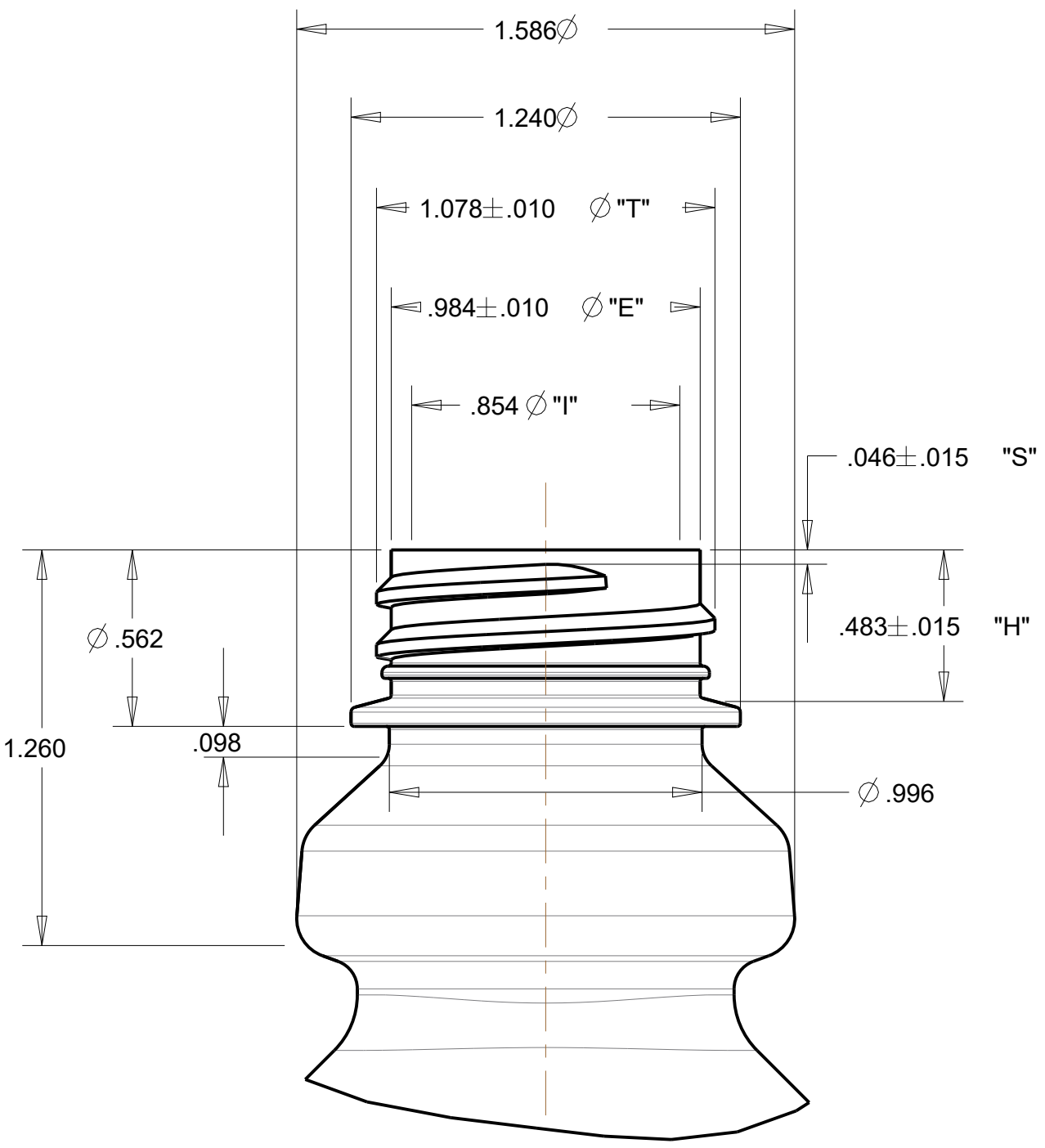

DETAIL A
SCALE 2.000
28-400 NECK FINISH
"M" STYLE THREAD
6 T.P.I.
PITCH-.167
1-1/4 FULL TURNS OF THREAD

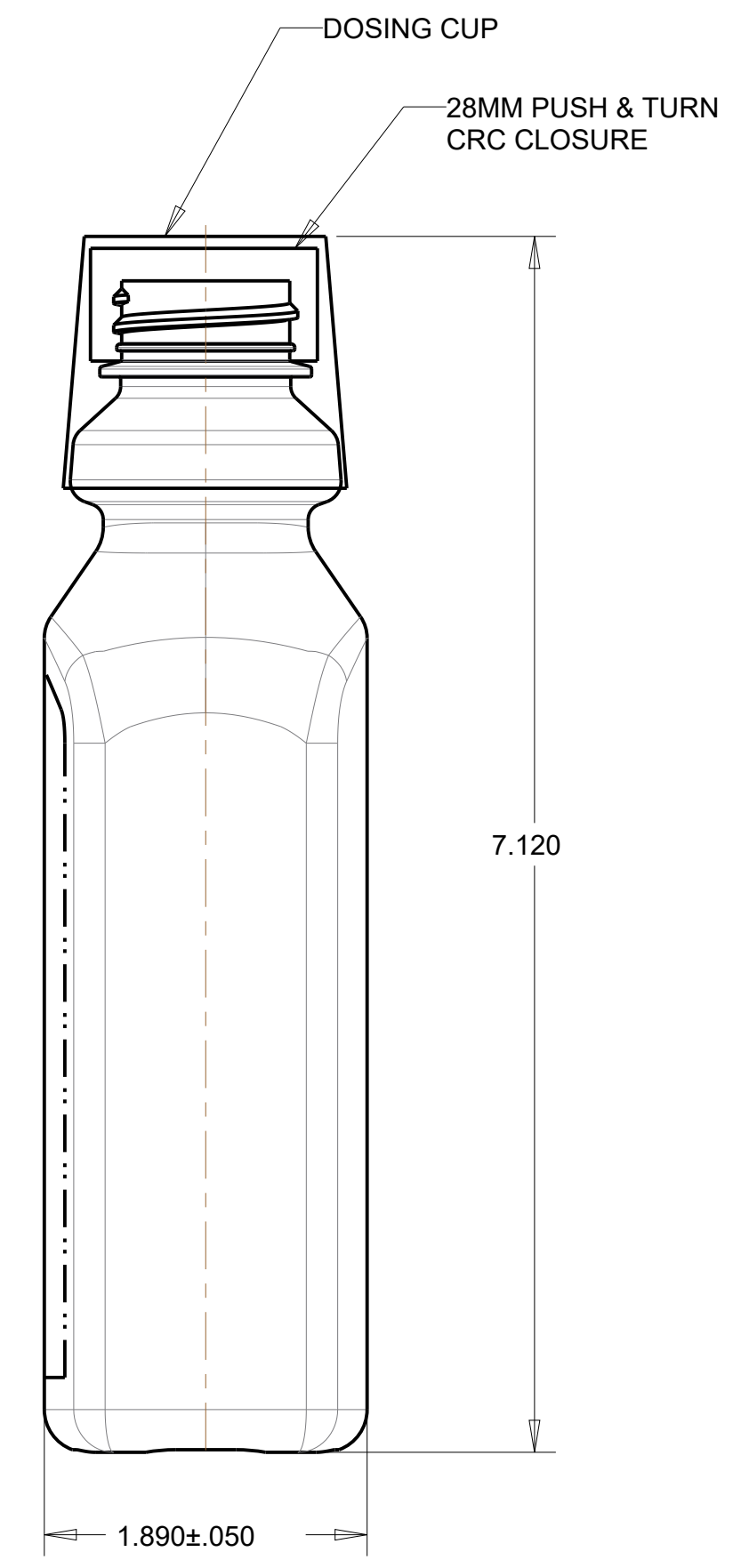
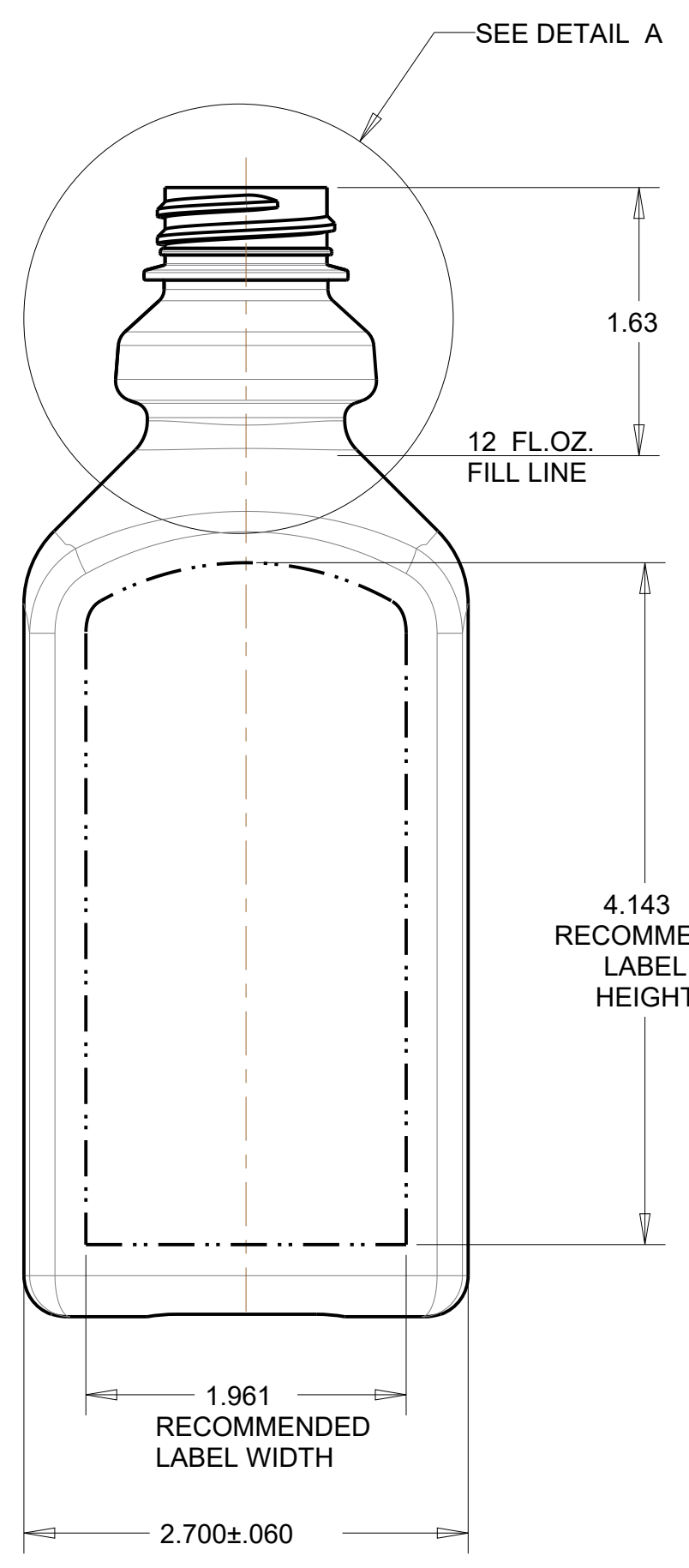
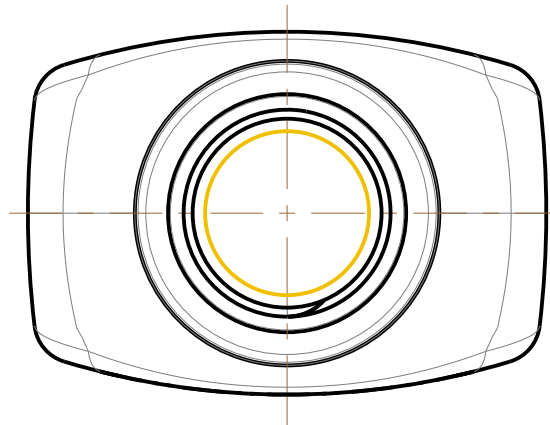

- NOTES:
1. NECK FINISH - 28-400
 2. MATERIAL - PETE
 3. BOTTLE WEIGHT - 30 ± 1.5 GRAMS
 4. OVERFLOW CAPACITY - 381.9 ± 9 ML

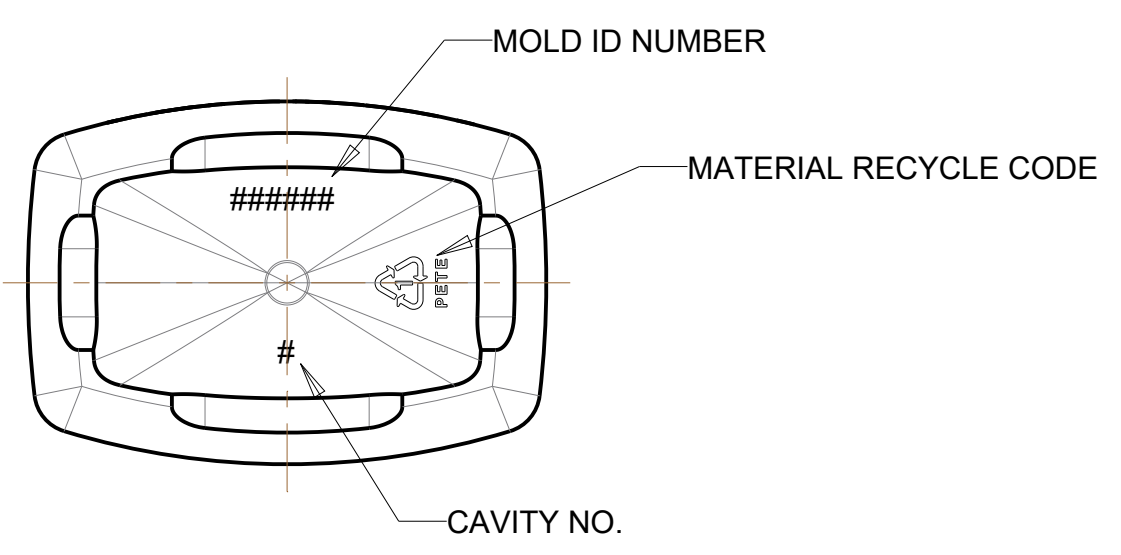

TOLERANCES (EXCEPT AS NOTED)				OCEAN STATE PACKAGING EXTRUSION AND INJECTION BLOW MOLDED BOTTLES	
DECIMAL	MATERIAL	SCALE	DRAWN BY		
S.P.I.	PETE	FULL	KSN		
FRACTIONAL	TITLE	APPROVED BY		MOLD NO	
S.P.I.	12 OZ. DOSING OBLONG				
ANGULAR	DATE	DRAWING NUMBER	REVISION		
S.P.I.	8/28/21	SS-1609-OS			