

DATE	SYM	REVISION RECORD	AUTH	DR	CK
2/19/19	A	DECREASED LABEL INDENT TO .033 FROM .040, OVERFLOW CAPACITY WAS 521.6 ML, ADJUSTED FILL LINE			KN

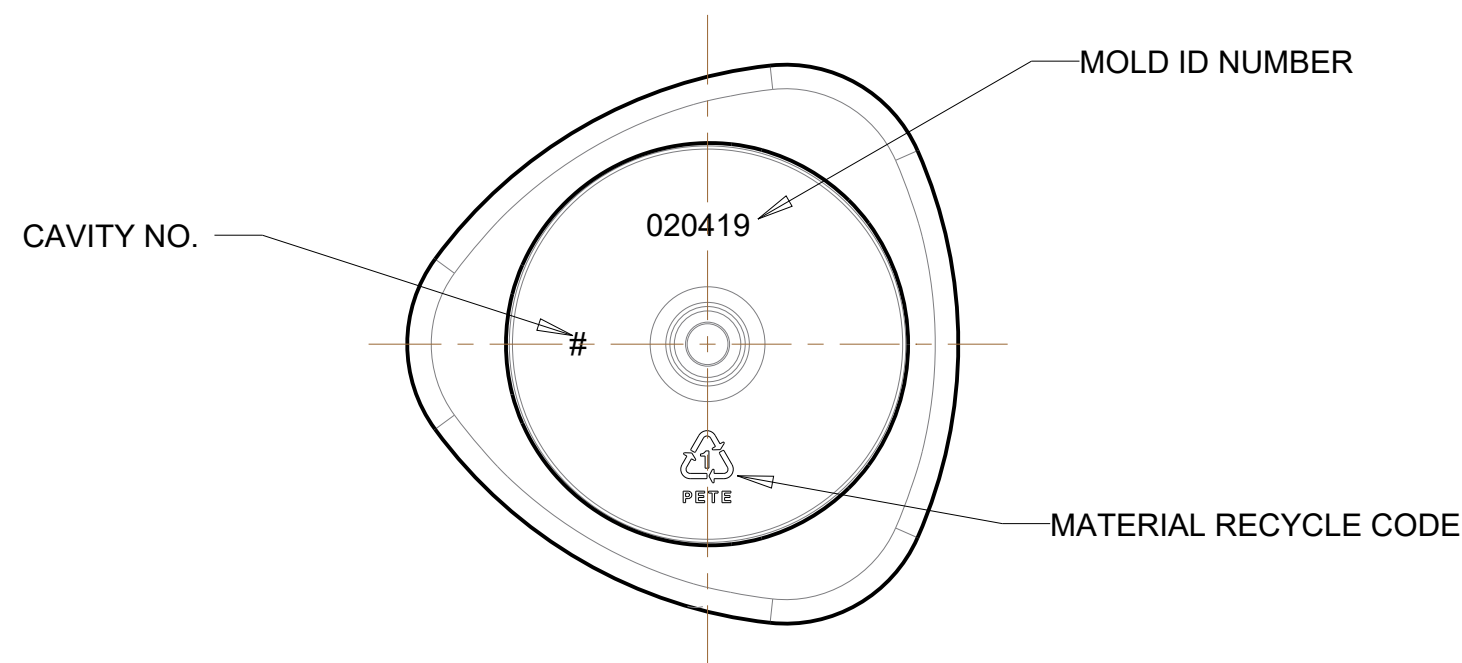
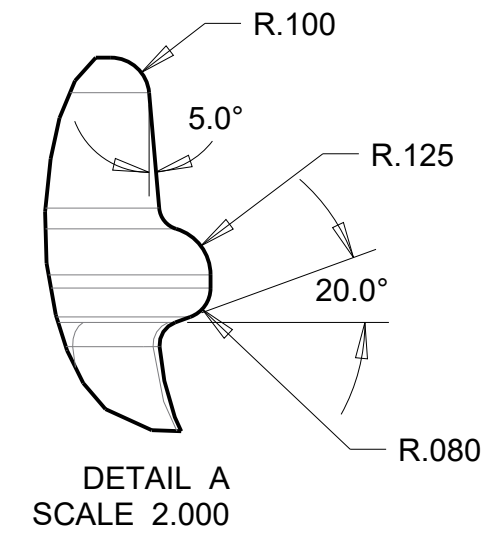
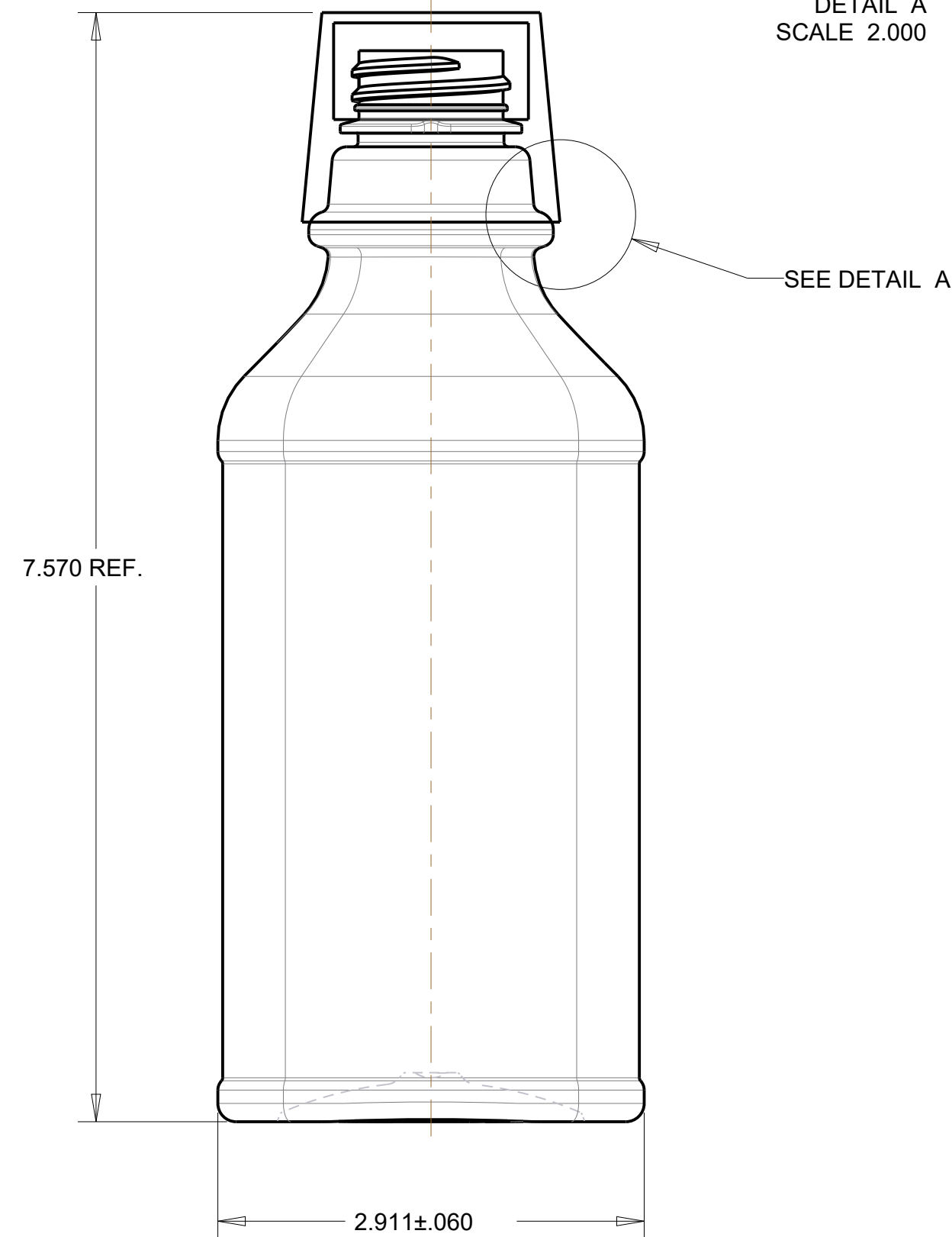
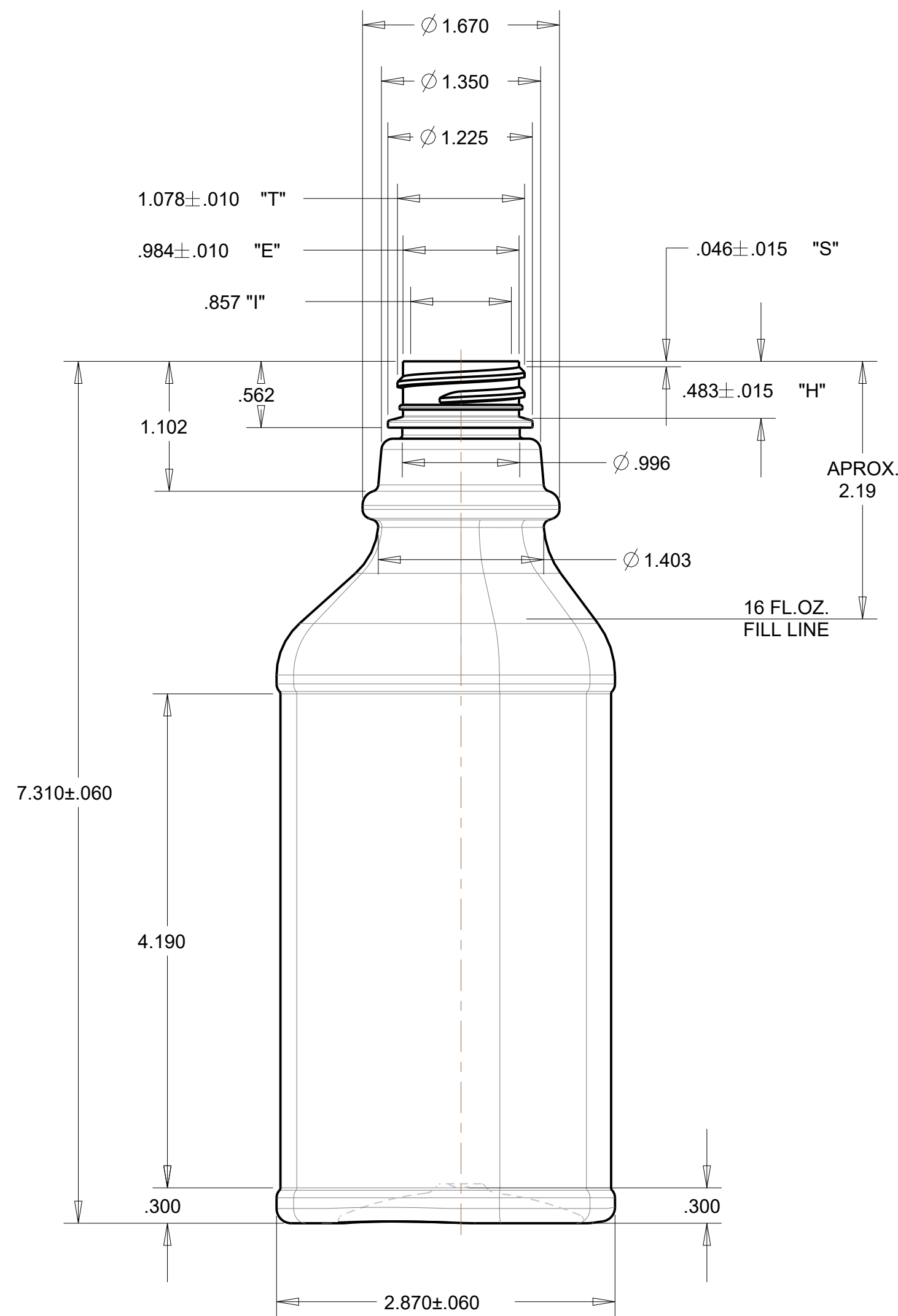

- NOTES:
1. NECK FINISH- 28-400
 2. MATERIAL- PETE
 3. BOTTLE WEIGHT- 44 ± 2 GRAMS
 3. OVERFLOW CAPACITY- 526.0 ± 11 ML

TOLERANCES (EXCEPT AS NOTED)		OCEAN STATE PACKAGING EXTRUSION AND INJECTION BLOW MOLDED BOTTLES		
DECIMAL	MATERIAL	SCALE	DRAWN BY	
S.P.I.	PETE	FULL	KSN	
FRACTIONAL	TITLE	APPROVED BY		MOLD NO
S.P.I.	16 OZ. TRIANGULAR			
ANGULAR	DATE	DRAWING NUMBER	REVISION	
S.P.I.	2/9/19	SS-1481-OS	A	