

DATE	SYM	REVISION RECORD	AUTH	DR	CK

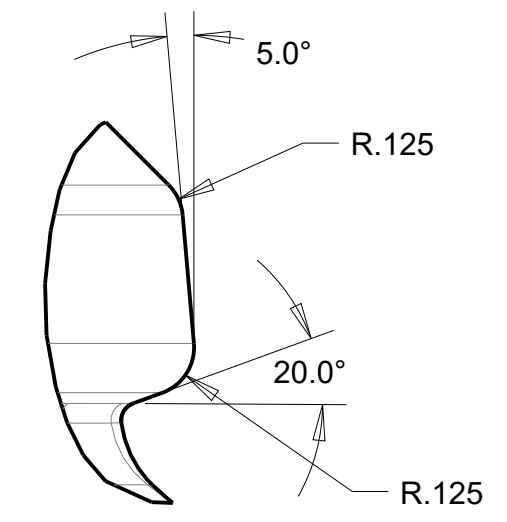

DETAIL A
SCALE 2.000

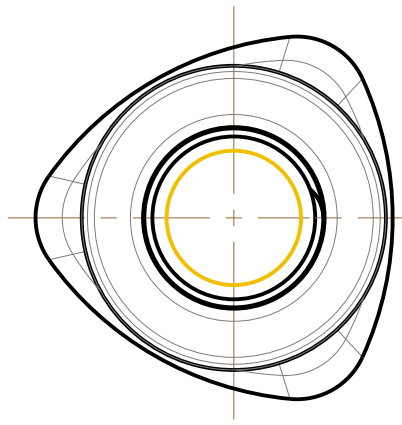
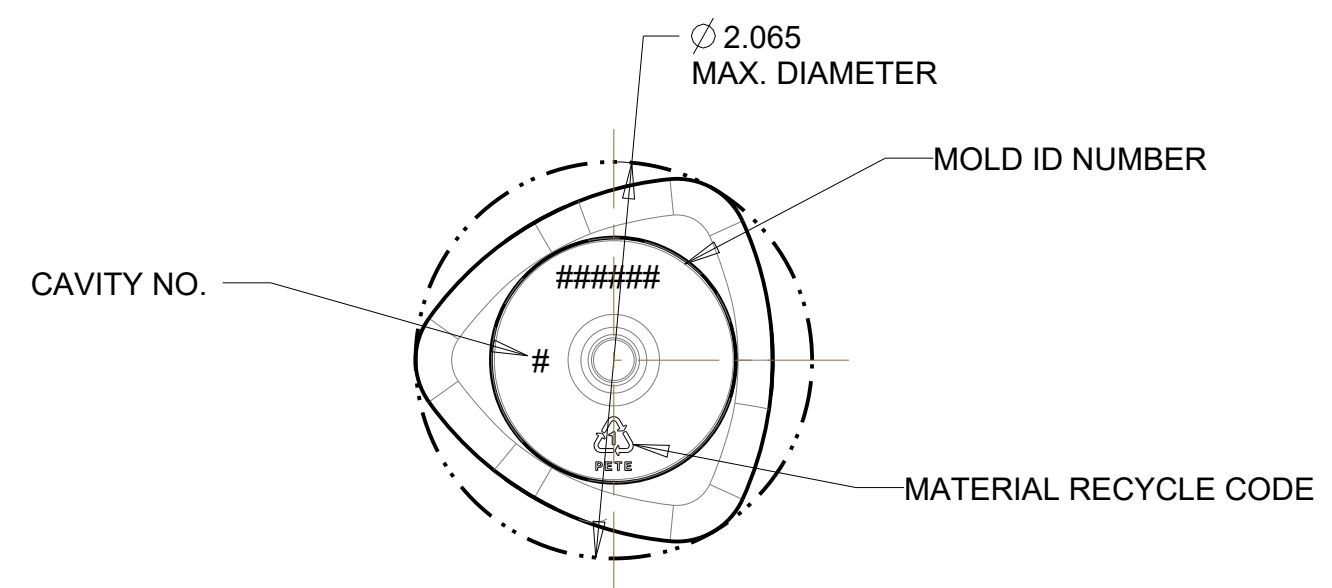
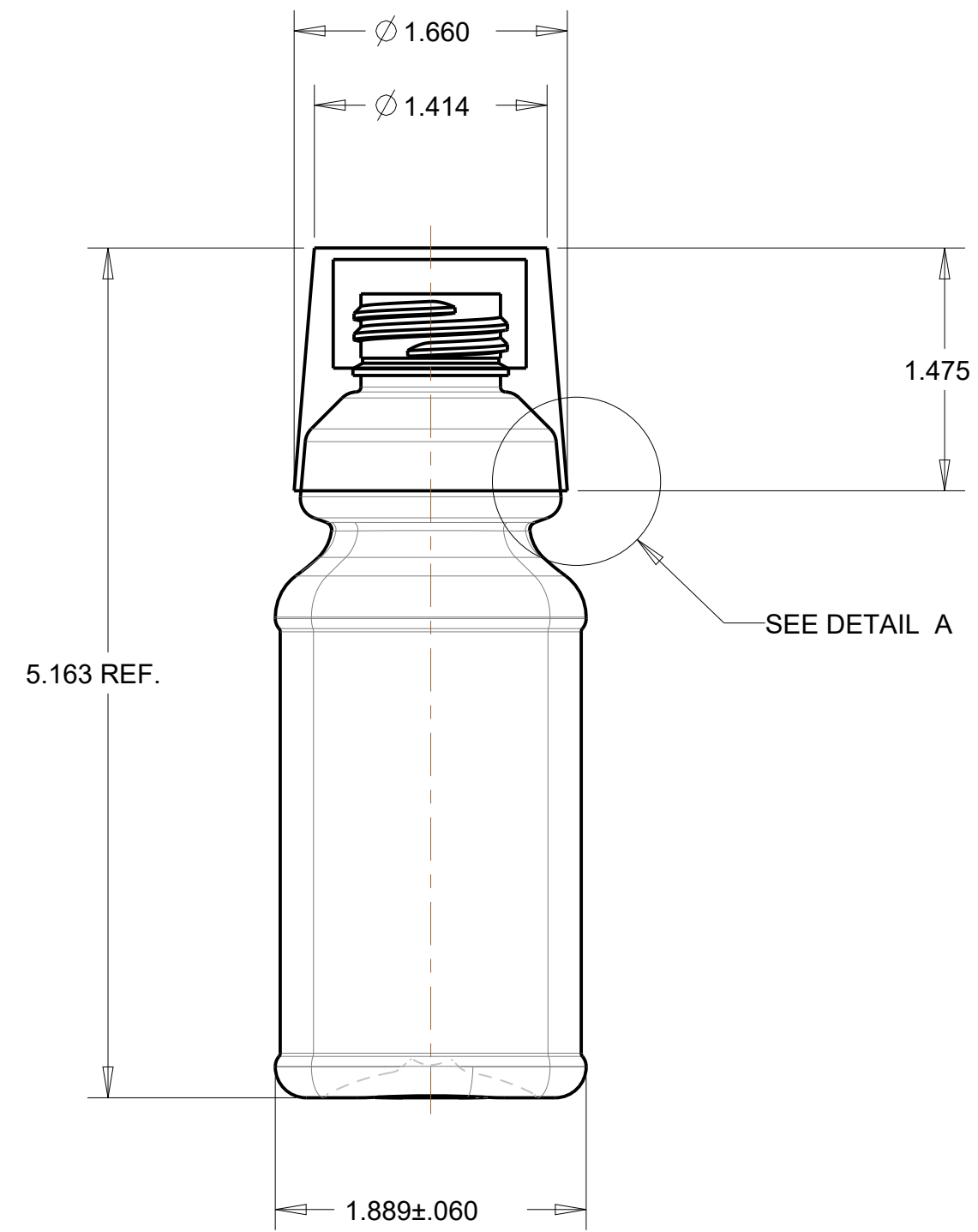
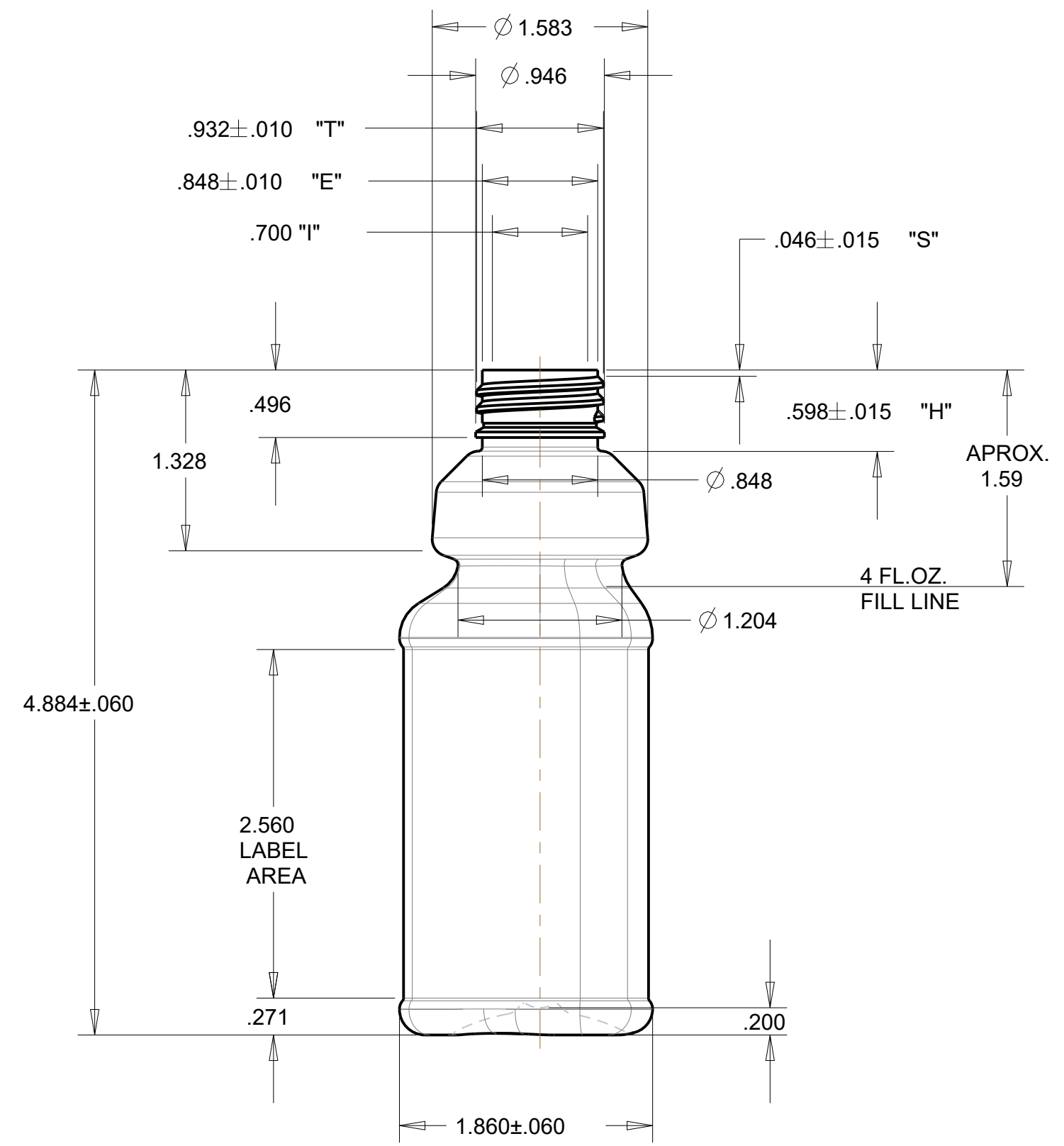

- NOTES:
1. NECK FINISH- 24-400
 2. MATERIAL- PETE
 3. BOTTLE WEIGHT- 18 ± 1.5 GRAMS
 4. OVERFLOW CAPACITY- 146.0 ± 5 ML
 5. LABEL PERIMETER - 5.69"
 6. HALF LENGTH- 5.878

TOLERANCES (EXCEPT AS NOTED)				OCEAN STATE PACKAGING EXTRUSION AND INJECTION BLOW MOLDED BOTTLES	
DECIMAL	MATERIAL	SCALE	DRAWN BY KSN		
S.P.I.	PETE	FULL	APPROVED BY		
FRACTIONAL	TITLE				MOLD NO
S.P.I.	4 OZ. TRIANGULAR				
ANGULAR	DATE	DRAWING NUMBER		REVISION	
S.P.I.	8/23/21	SS-1608-OS			