

NECK FINISH	BOTTLE WEIGHT (± 1.5 GR)	OVERFLOW CAPACITY (± 11 CC)	"T" DIA	"E" DIA	"H" DIM	"S" DIM	"I" DIA	MATERIAL
28-410 SPECIAL	22.0	255.2	1.088 1.068	.994 .974	.797 .767	.061 .031	.868 .848	PETE

DATE	SYM	REVISION RECORD	AUTH	DR	CK
6/11/20	A	.812 SHOULDER RADIUS WAS .937, OFC WAS 253.0 CC, 3.00 LABEL HEIGHT WAS 2.900			KSN

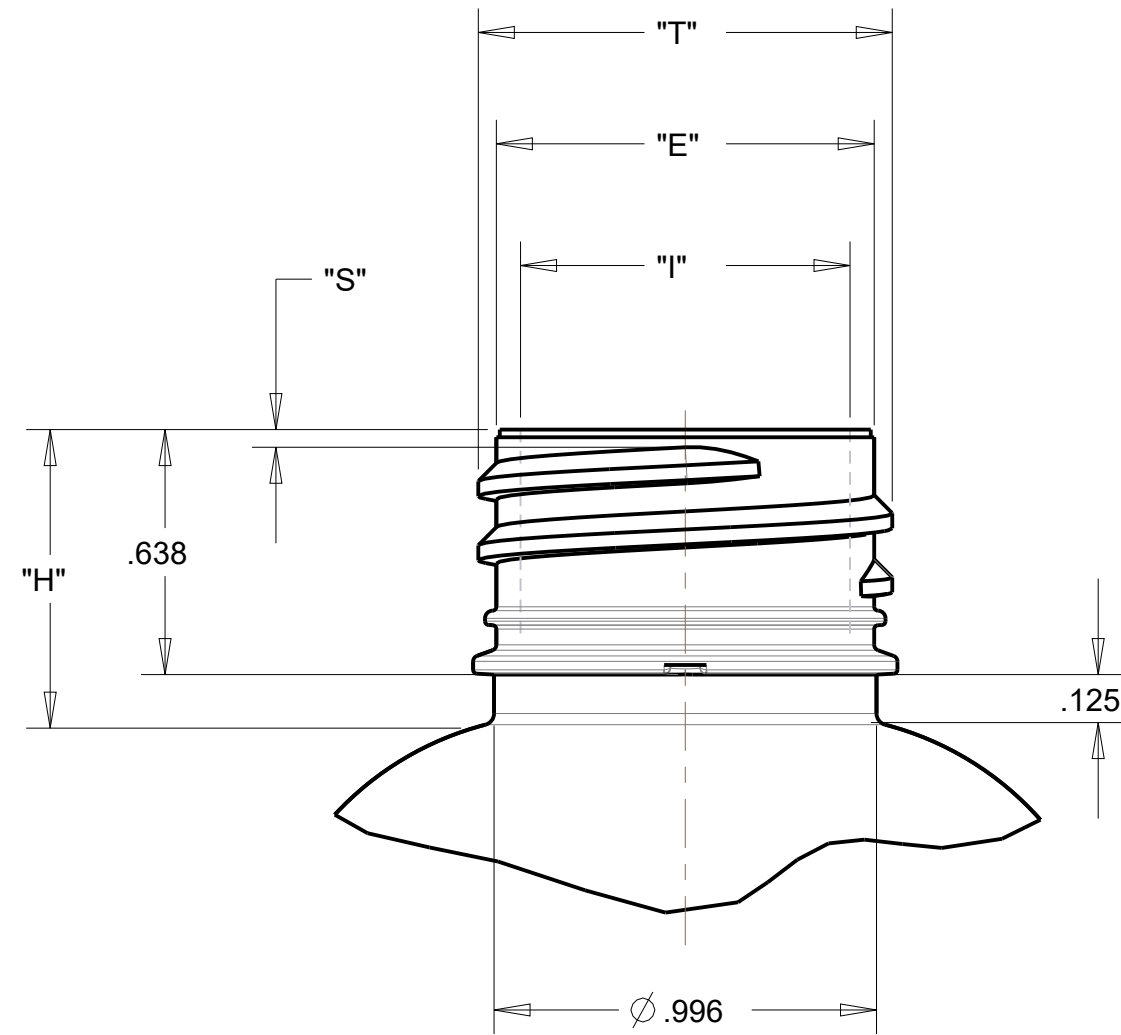

DETAIL A
SCALE 2.000
"M" STYLE THREAD
6 THREADS PER INCH
PITCH - .167
1-3/4 FULL TURNS OF THREAD

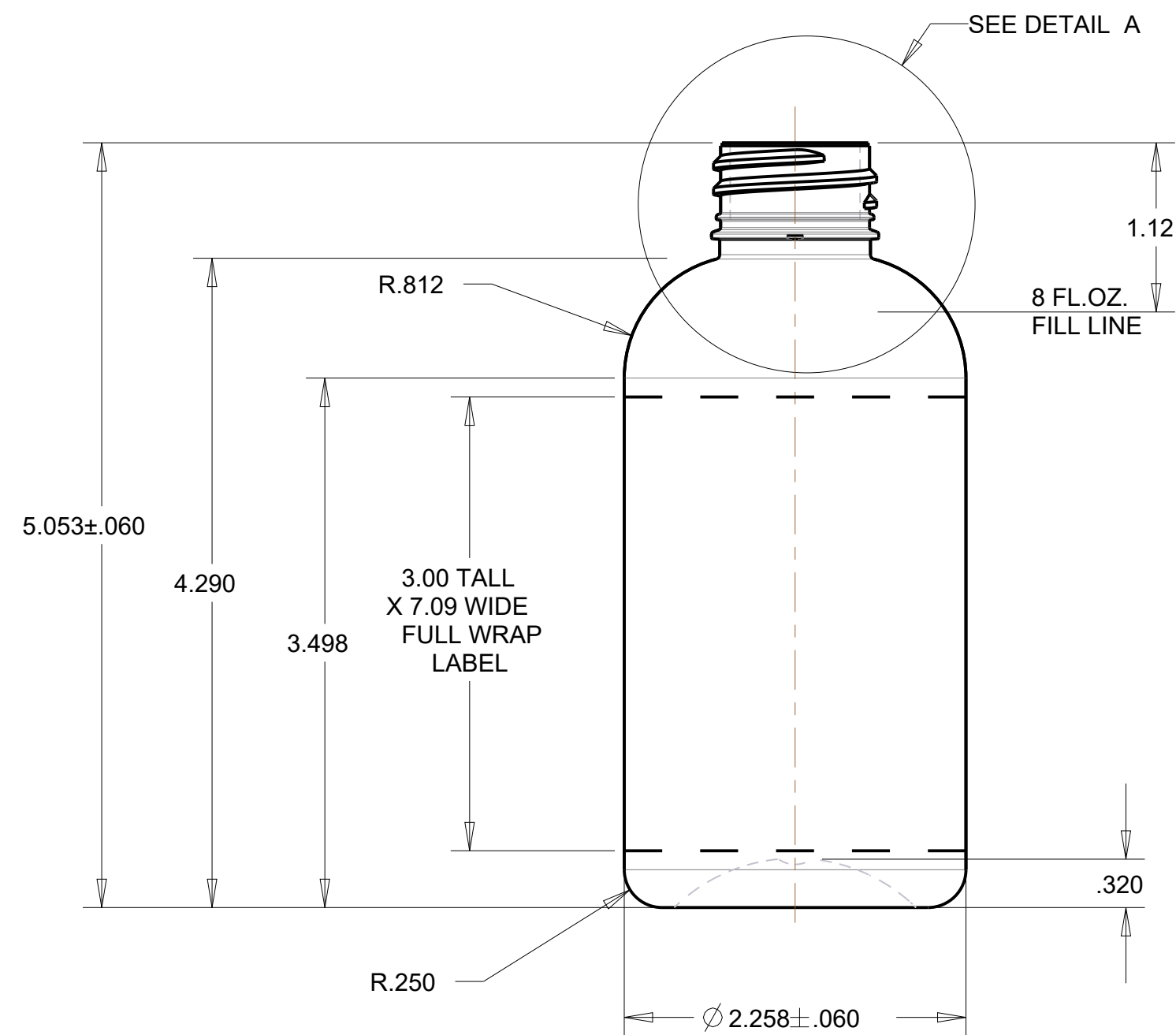
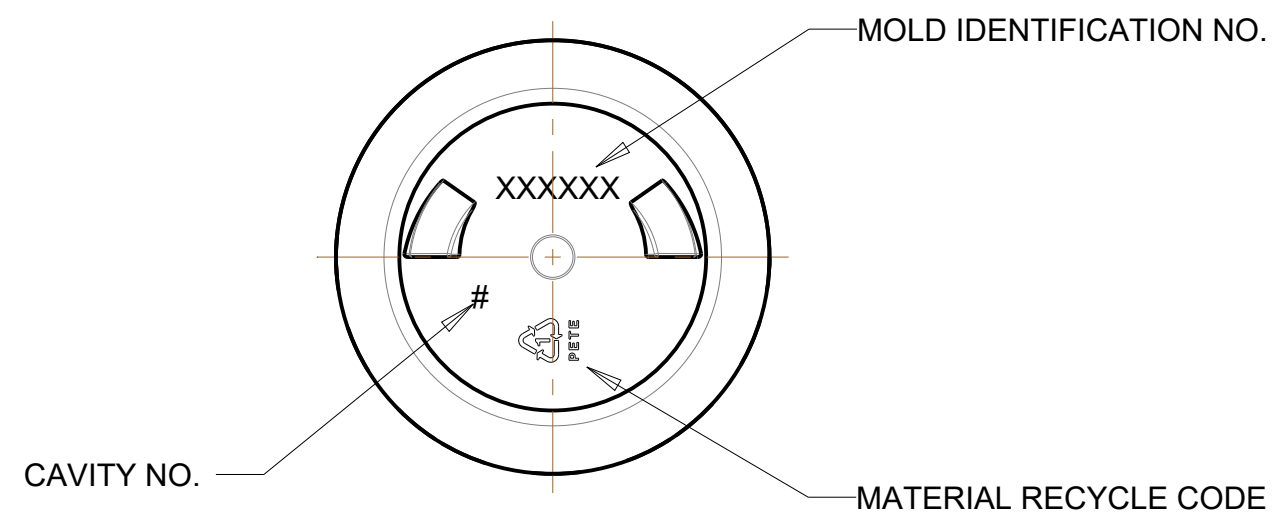

TOLERANCES (EXCEPT AS NOTED)		OCEAN STATE PACKAGING EXTRUSION AND INJECTION BLOW MOLDED BOTTLES			
DECIMAL	MATERIAL	SCALE	DRAWN BY		MOLD NO
S.P.I.	PETE	FULL	KSN		
FRACTIONAL	TITLE	APPROVED BY			REVISION
S.P.I.	8 OZ. BOSTON ROUND				
ANGULAR	DATE	DRAWING NUMBER			
S.P.I.	5/27/20	SS-1554-OS			A