

NECK FINISH	BOTTLE WEIGHT ±3 GRAMS	OVERFLOW CAPACITY ±20 CC	"T" DIA.	"E" DIA.	"H" DIM.	"S1" DIM.	"I" DIA.
63 MM SQ. LK.	55.0	1120.3*	2.461 2.426	2.367 2.332	.965 .935	.167 .137	1.972 MIN.

DATE	SYM	REVISION	BY

\*OVERFLOW CAPACITY IS BEFORE DECO

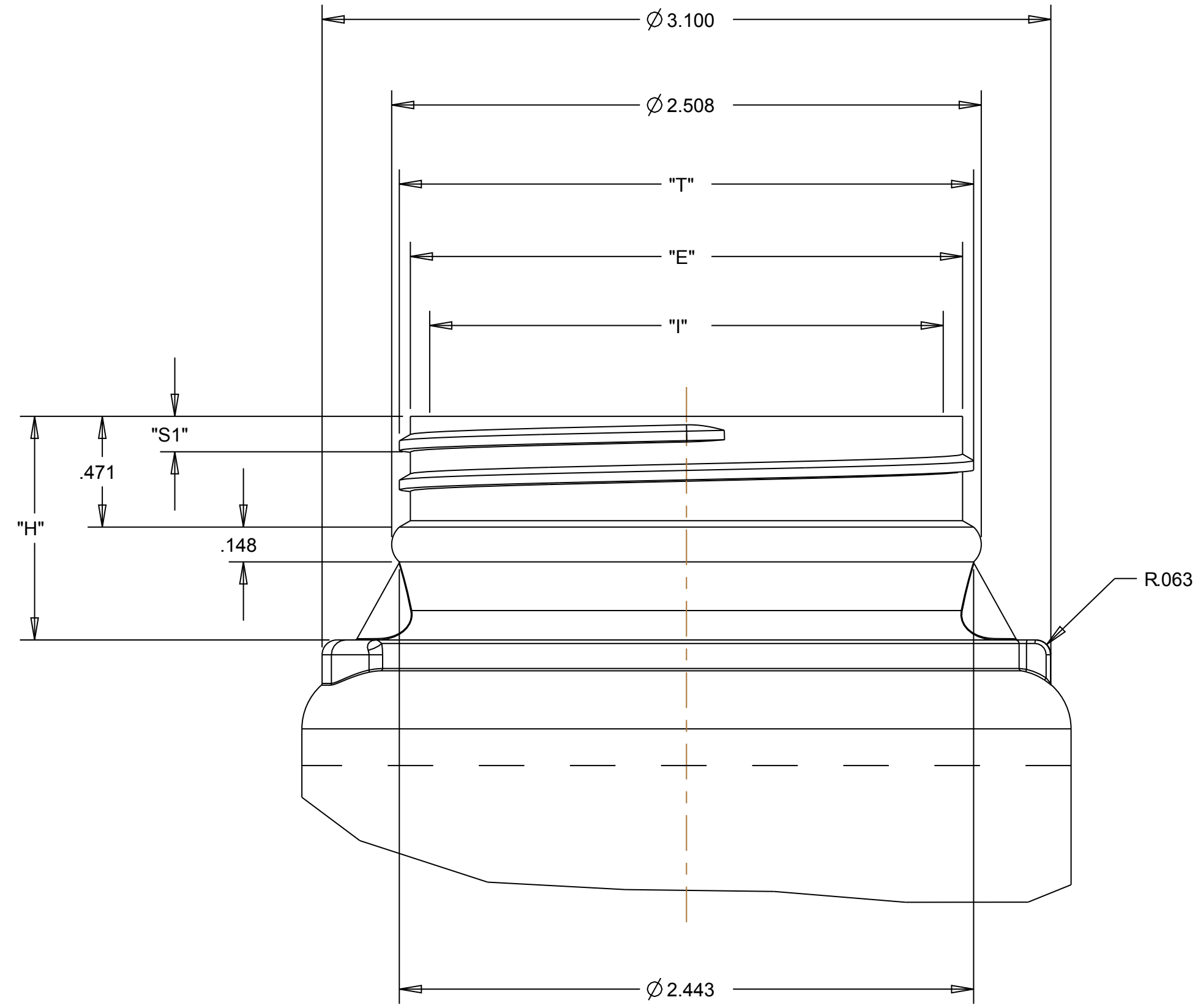
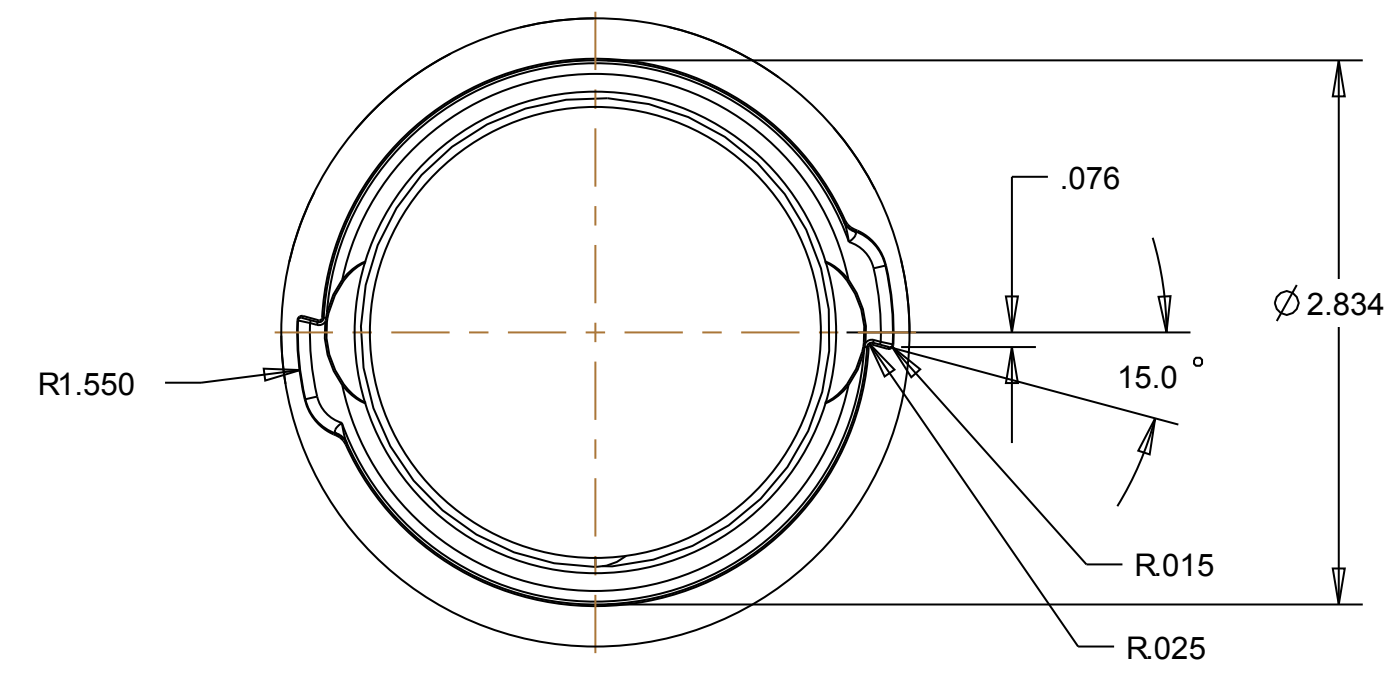

DETAIL A  
SCALE 2.000

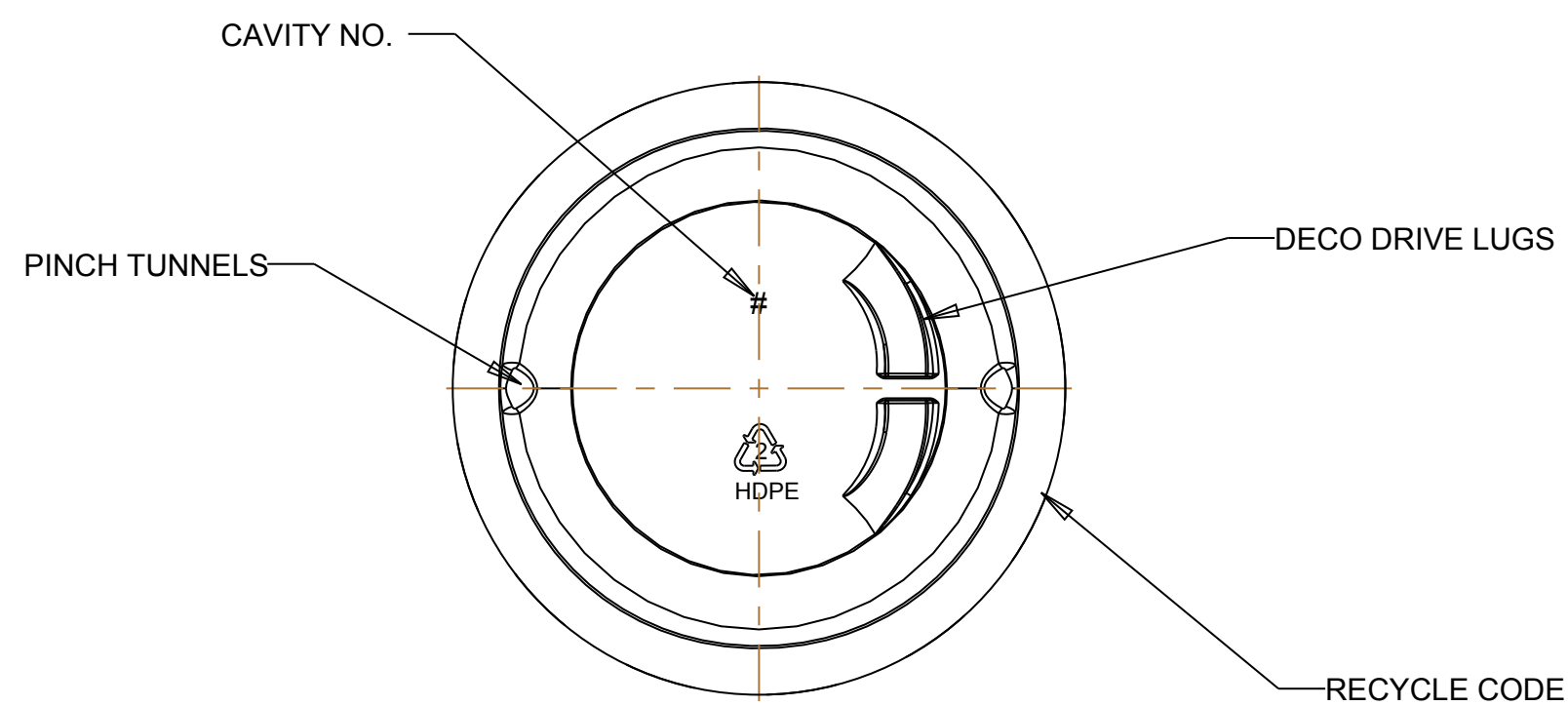
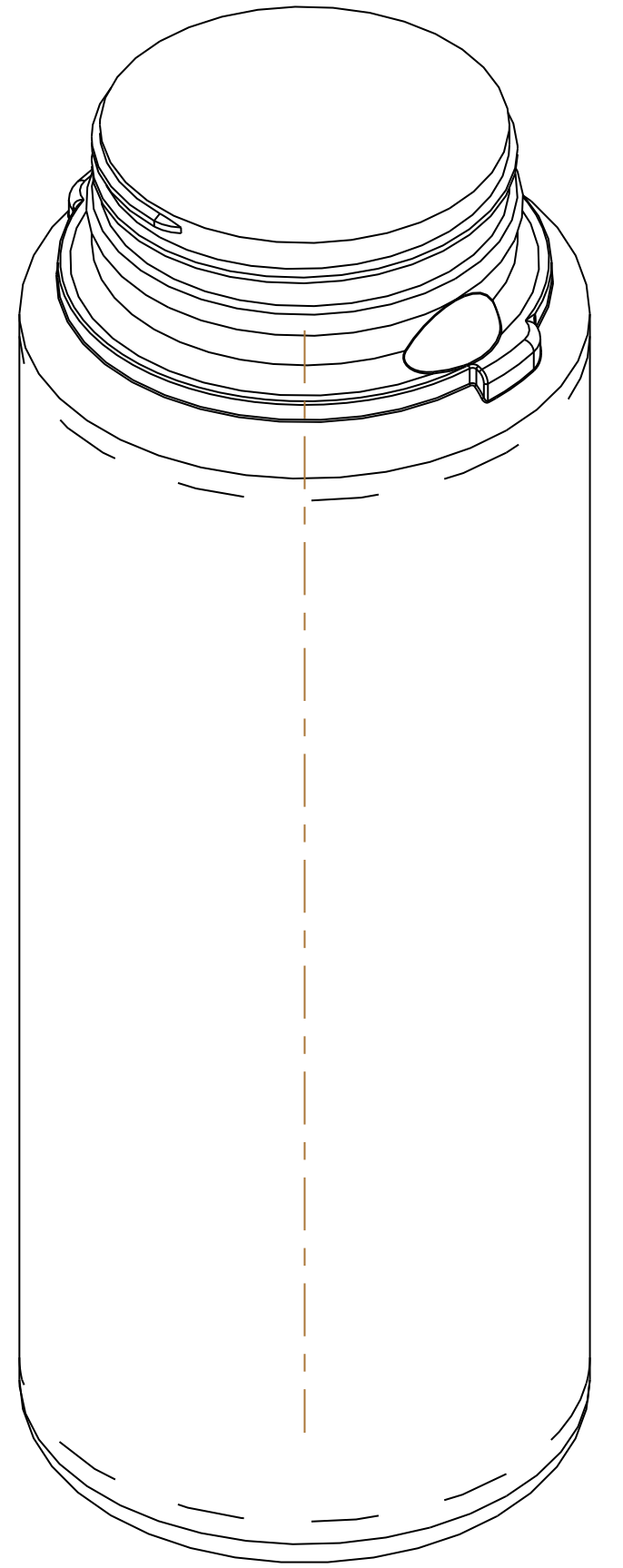
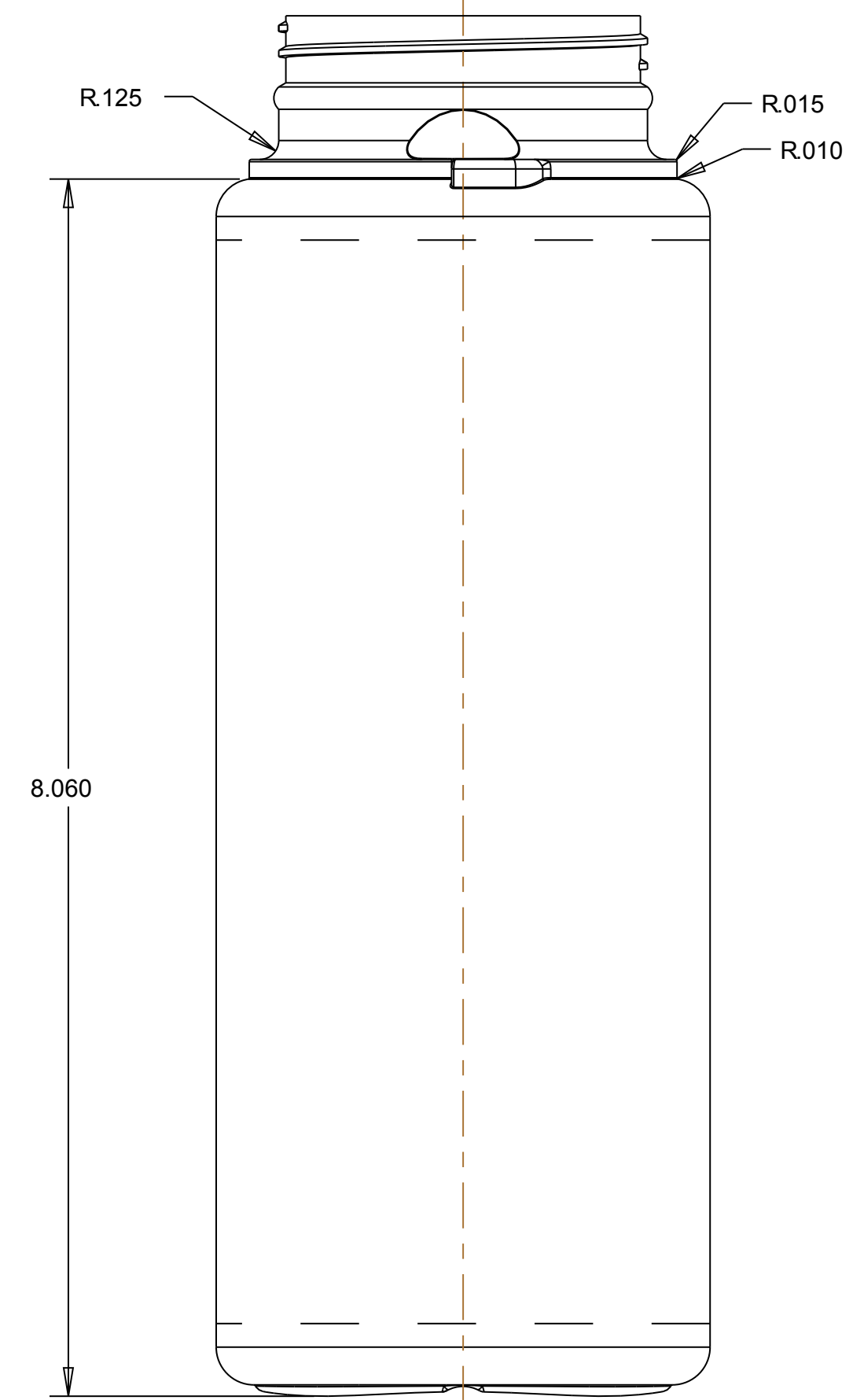
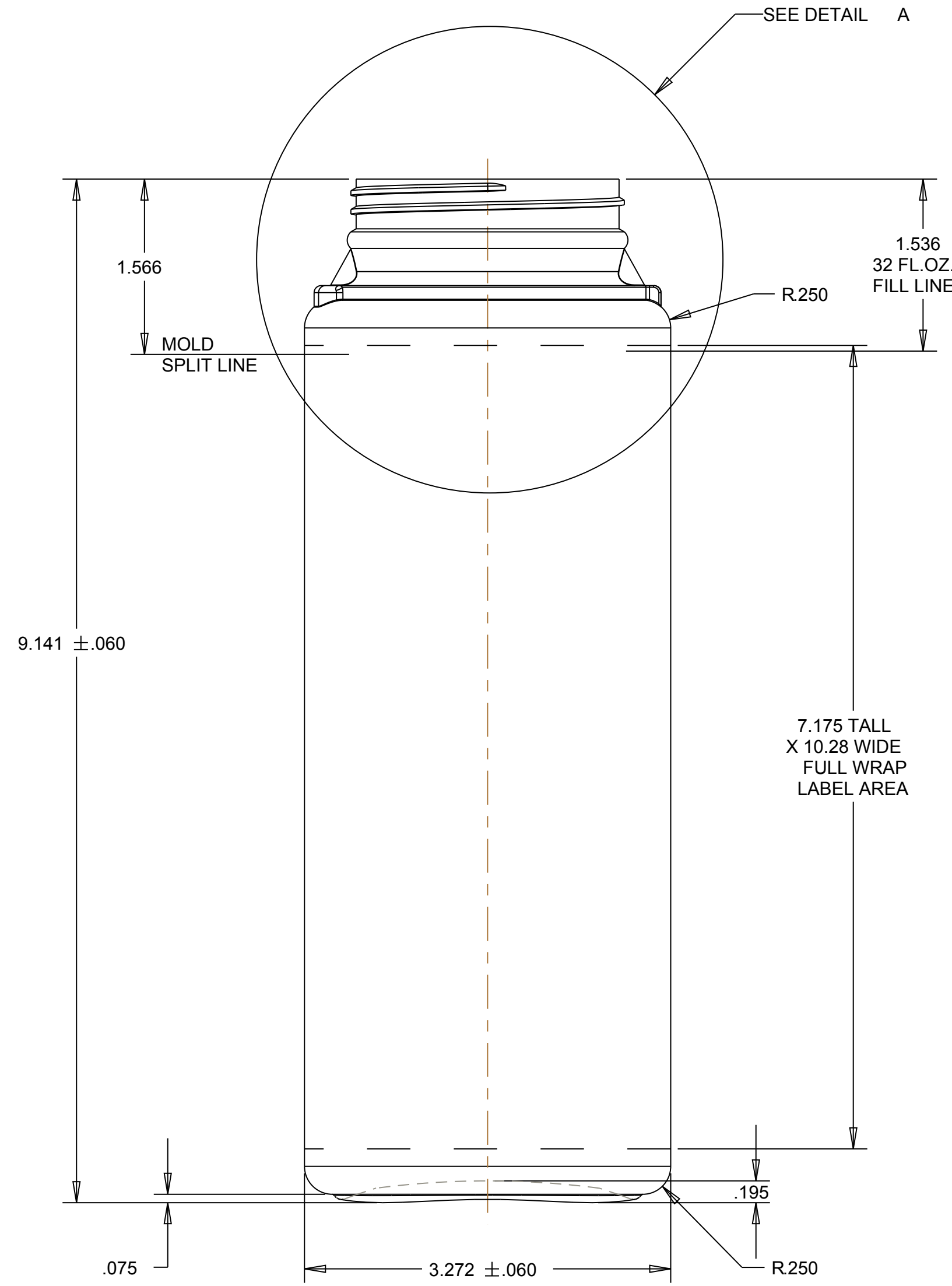

<b>OCEAN STATE PACKAGING</b> EXTRUSION AND INJECTION BLOW MOLDED BOTTLES			
TOL S.P.I.	TITLE 32 OZ WM CYLINDER ROUND		
DATE 4/1/13	DRAWING NO. SS-1213-OS	REV	