

REVISIONS

NO.	BY	DESCRIPTION	DATE
A1	CML	ADDED STEP AT BASE OF NECK	MAY.24/22
B1	CML	CHANGED SHAPE OF NECK RING	JUNE.3/22
C1	CML	OD WAS 1.710" WEIGHT WAS 15g	JUNE.17/22
D1	CML	OAH WAS 6.102" OD WAS 1.735" OFC WAS 192ml	JUNE.23/22
D2	CML	RADIUS WAS 0.750" AND 0.200" NOW 0.938" AND 0.172"	JUNE.23/22
E1	CML	RADIUS WAS 0.172"	JUNE.23/22
F1	CML	ADDED SECOND PUSHUP	JUNE.24/22
G1	CML	RADUIS WAS 0.938" OAH WAS 6.260" OFC WAS 195ml	JUNE.27/22

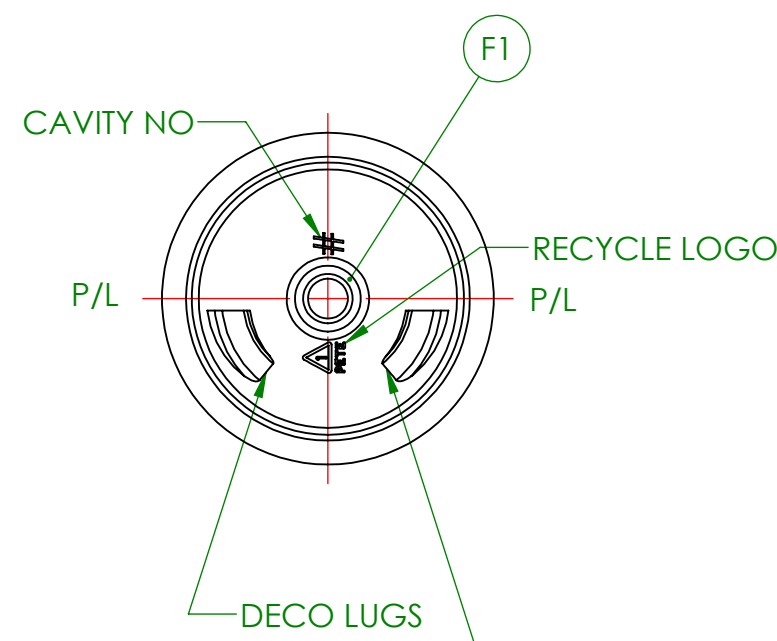
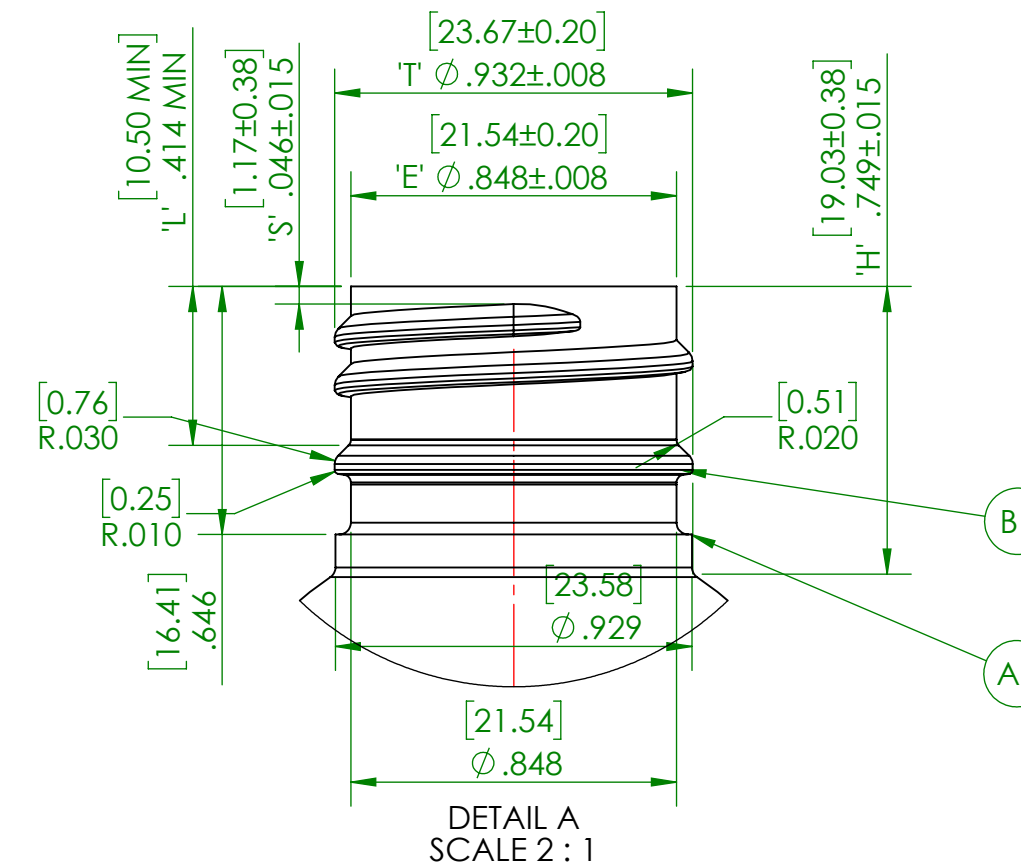
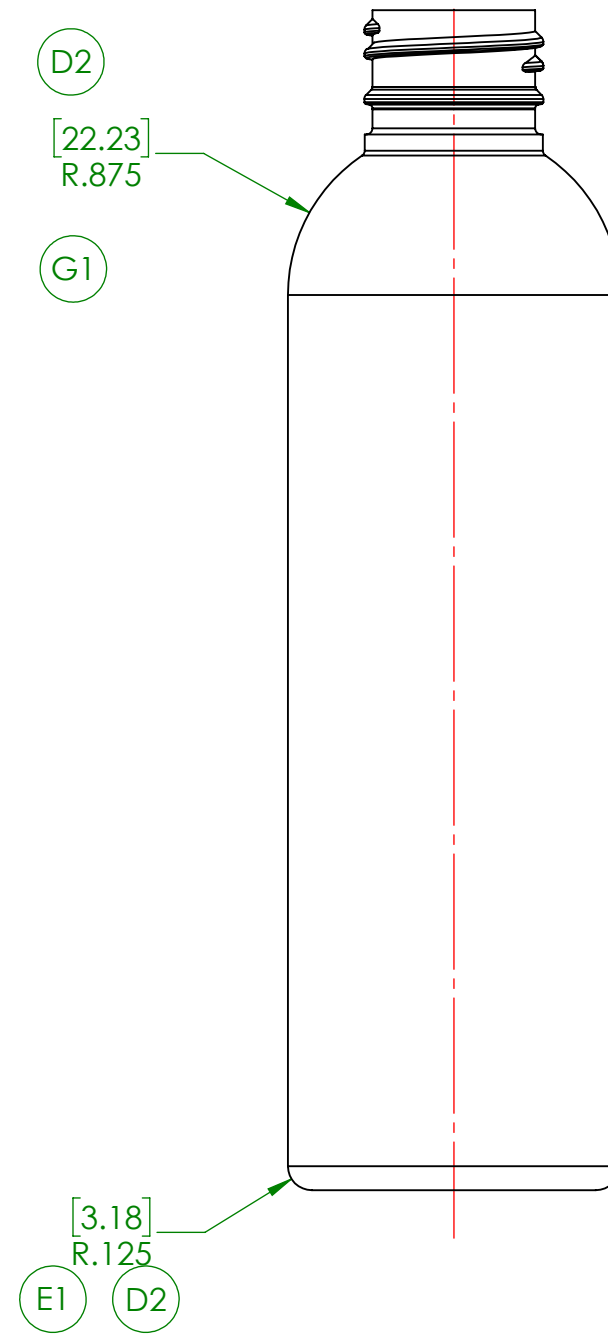
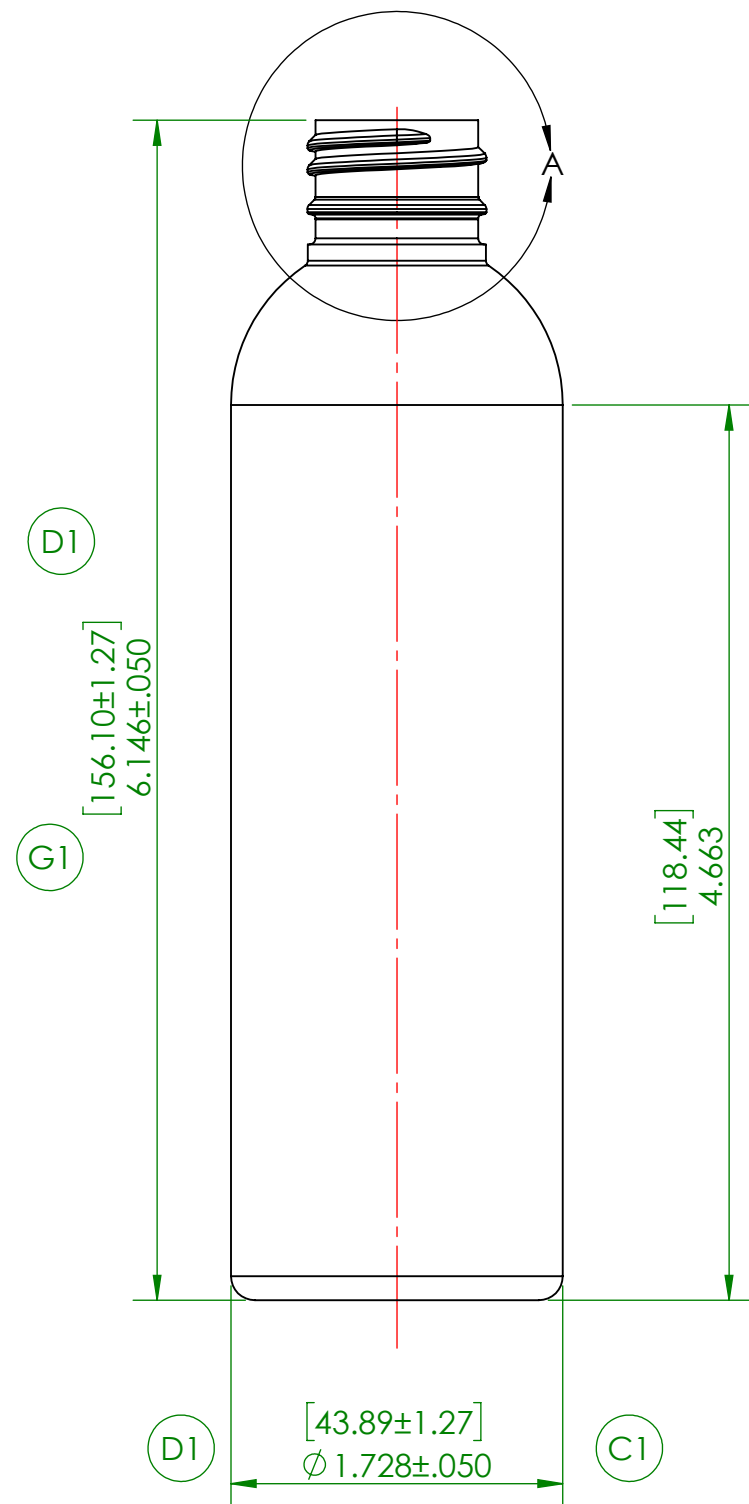

TEMPORARY DRAWING-NOT RELEASED FOR PRODUCTION

THIS IS A SUGGESTED DESIGN FOR CUSTOMER APPROVAL. FINAL SIZES AND VOLUME ARE SUBJECT TO MOULDING SPECIFICATIONS AND PRODUCTION QUALIFICATIONS.

DRAWING CHECKED SPECIFICALLY FOR:
 NECK FINISH
 WEIGHT
 CAPACITY
 MATERIAL
 SPECIAL REQUESTS
 PRODUCT DESIGN TO BE APPROVED BEFORE MOULD CAVITIES ARE MACHINED.
 APPROVED BY
 DATE
 This drawing subject to standard industry tolerances S.P.I.



CAPACITY TO FILL LEVEL: 177 ml ± 6	
OVERFLOW CAPACITY: 191.5 ml ± 6 (D1) (G1)	
NECK FINISH: M24-410 SPECIAL	WEIGHT: 20g ± 1.5 (C1)
DRAWN BY: CML	DESC. 6 OZ Bullet
SCALE: 1:1 DATE: 5/5/22	DRAWING NO. 44223-8G
BOTTLE MAT'L: PETE	MOULD NO.
CAD NAME:PD	