

DATE	SYM	REVISION RECORD	AUTH	DR	CK

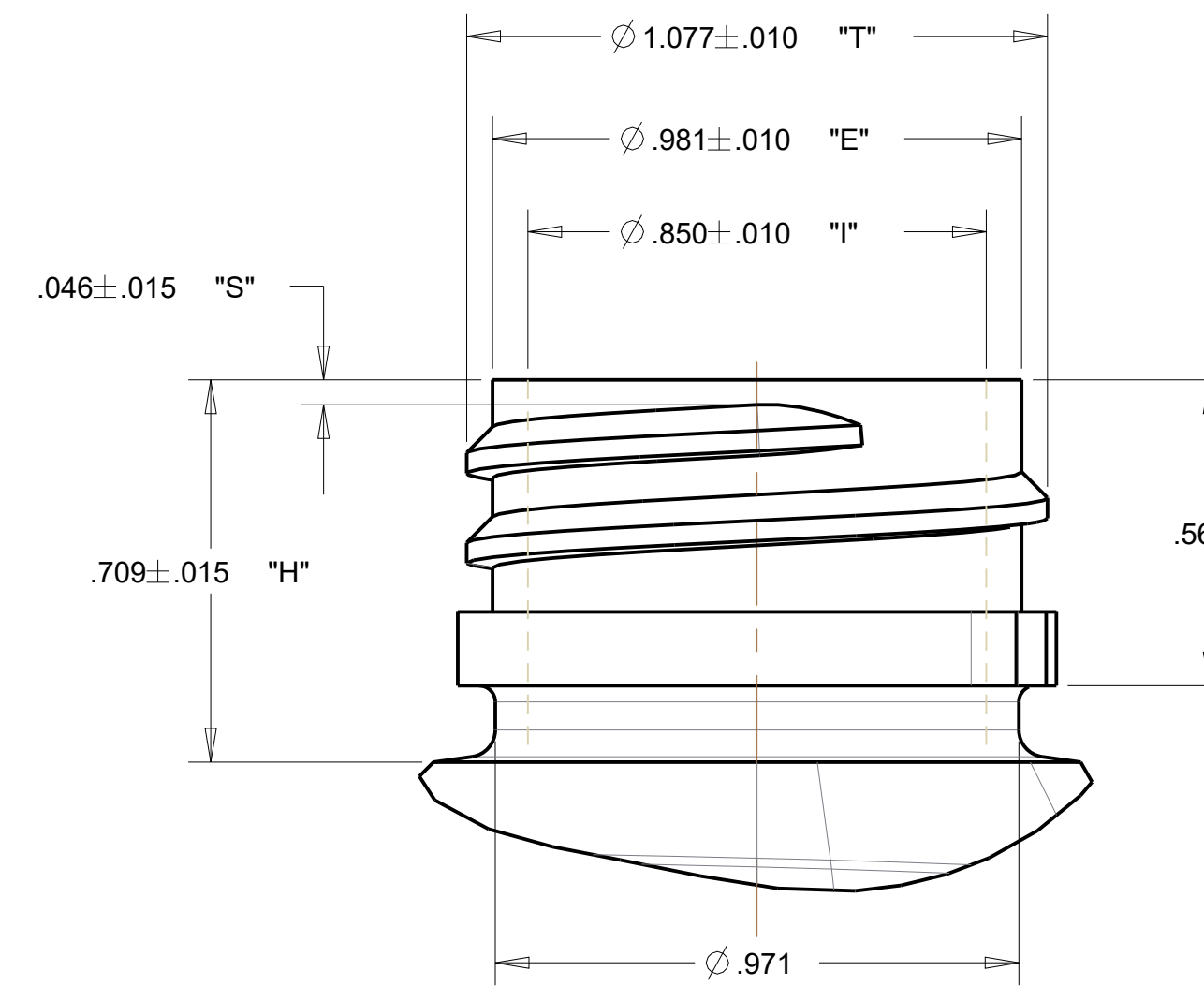

DETAIL A
SCALE 3.000
28MM RATCHET NECK FINISH
6 THREADS PER INCH
PITCH- .167
1-1/4 FULL TURNS OF THREAD

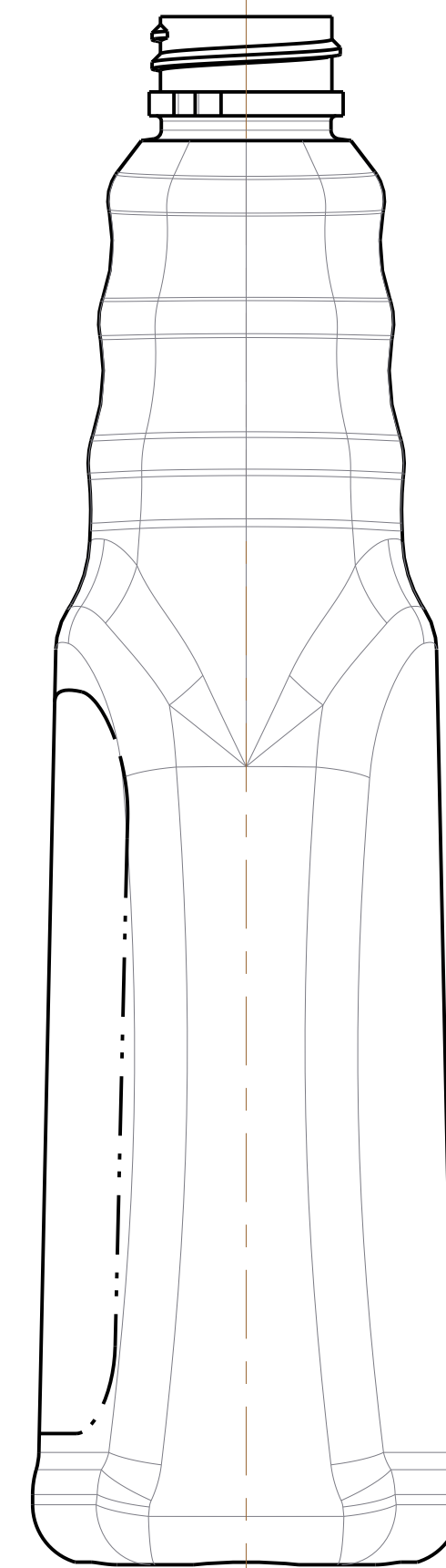
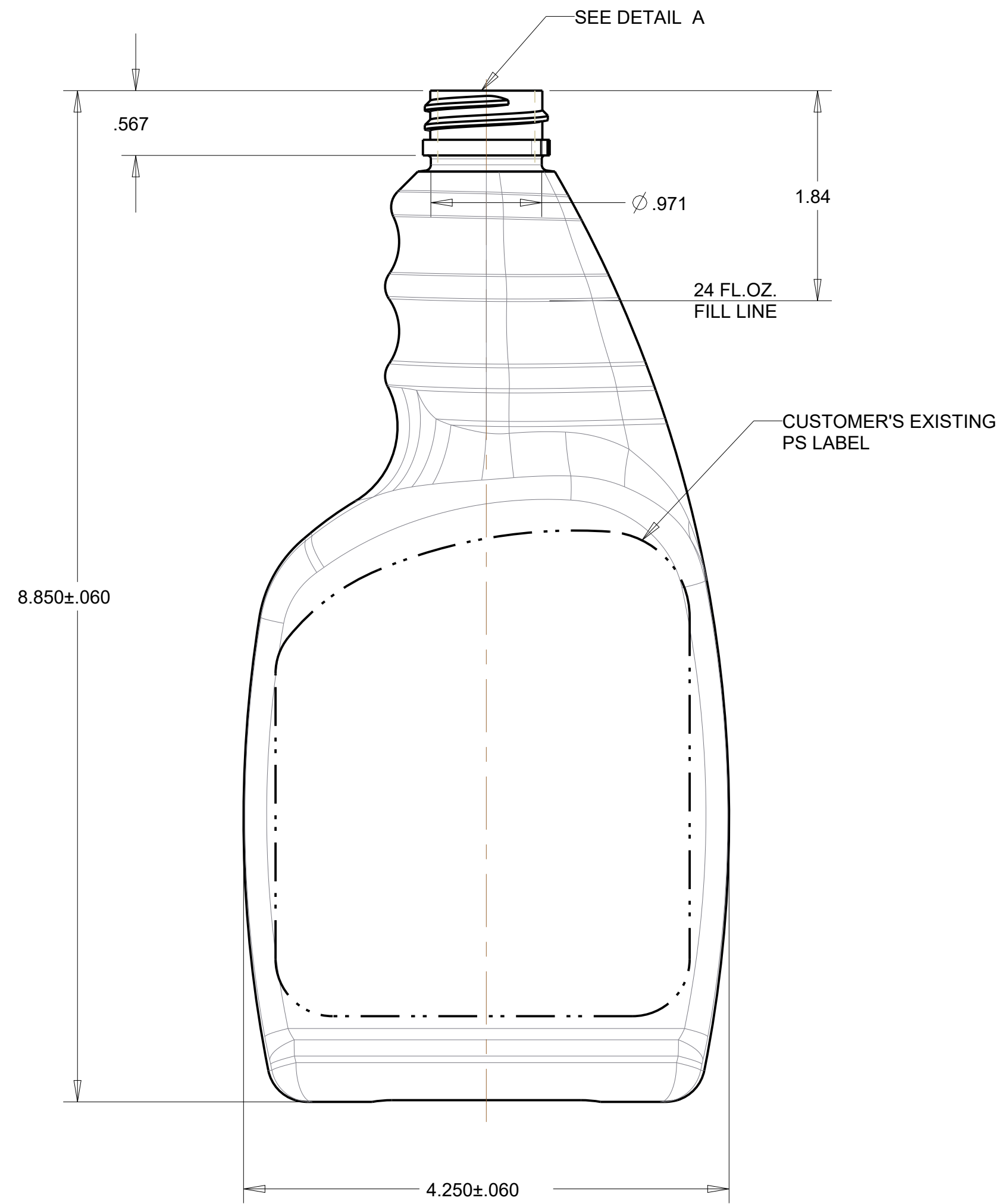
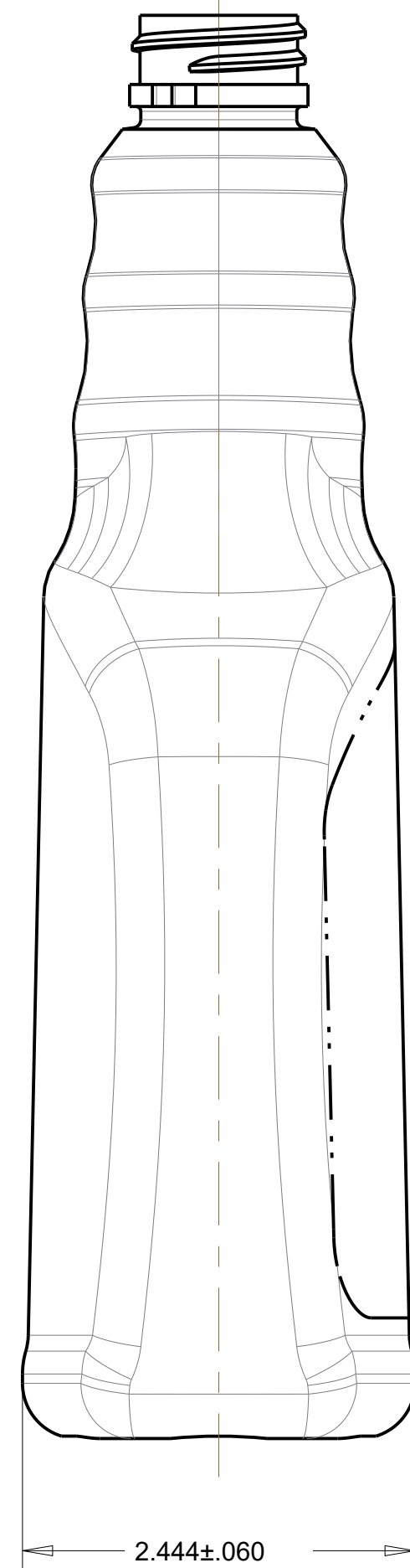
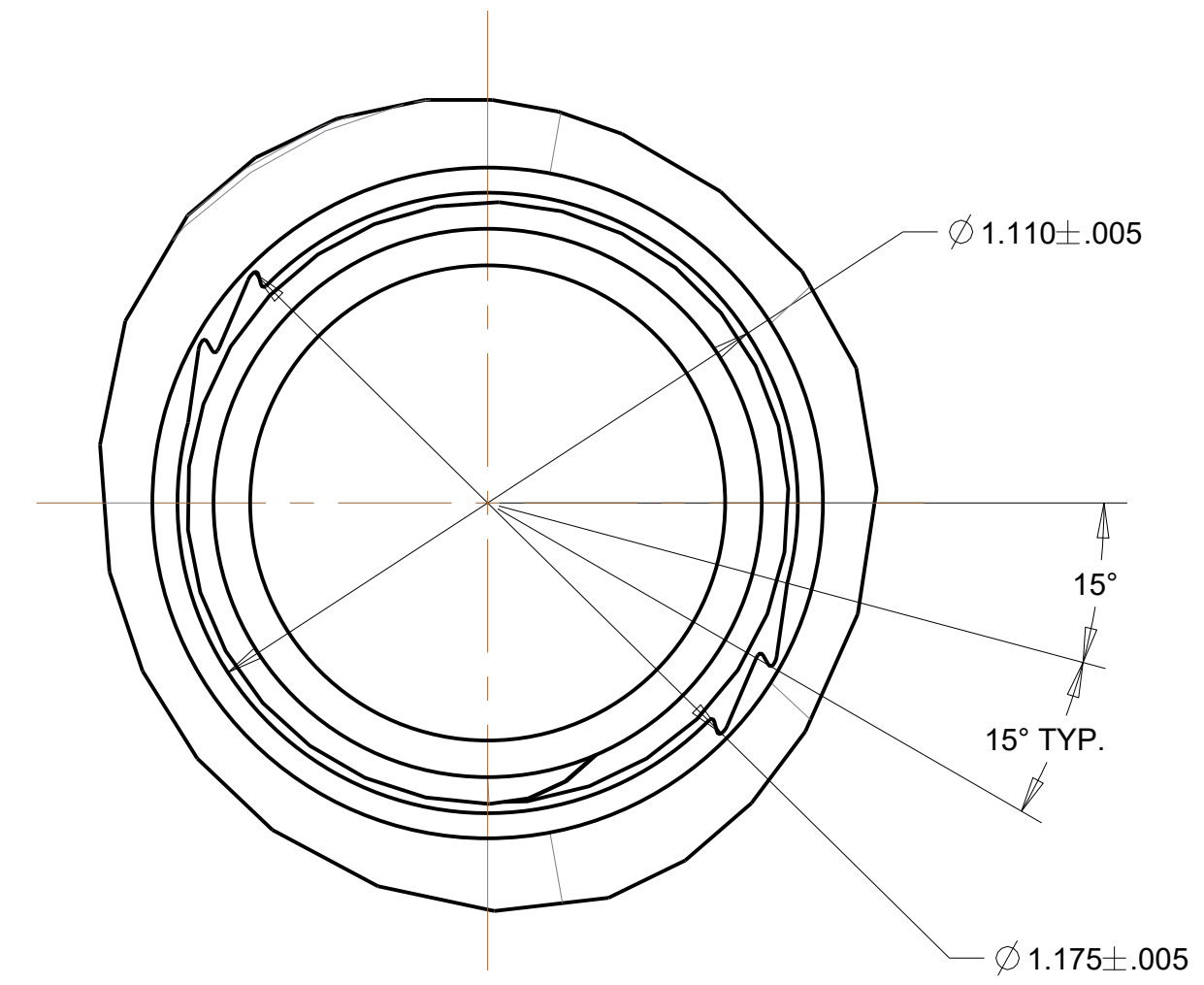
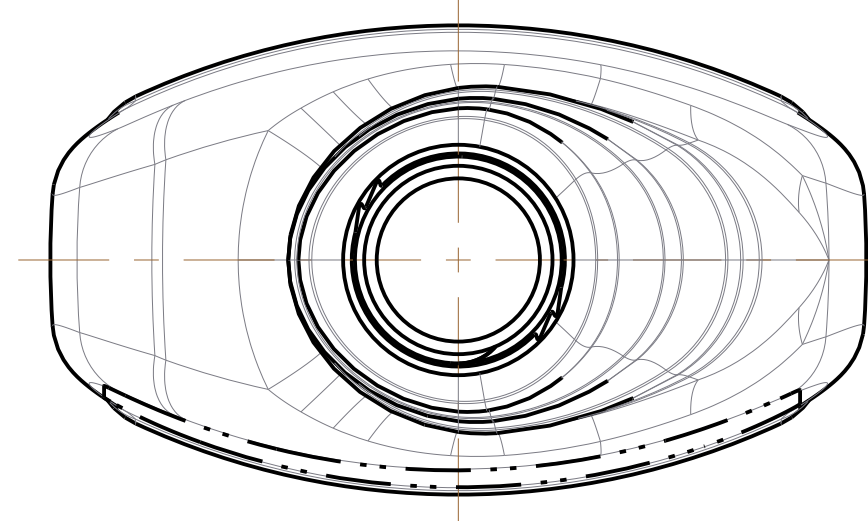
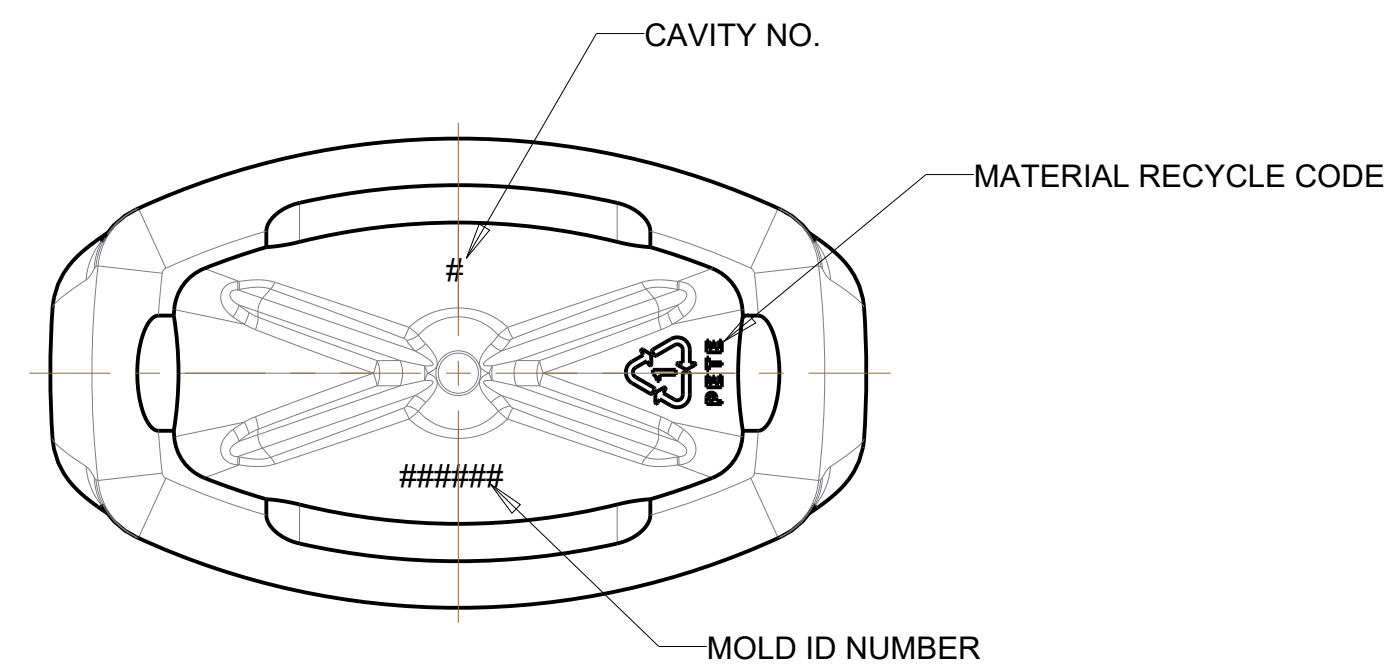

NOTES:

1. WEIGHT - 44.5 ± 2 GRAMS
2. OVERFLOW CAPACITY - 756.0 ± 13 ML
3. 28MM RATCHET NECK FINISH
4. MATERIAL- PETE

TOLERANCES (EXCEPT AS NOTED)				
DECIMAL	MATERIAL	SCALE	DRAWN BY	KSN
FRACTIONAL	PETE	FULL	APPROVED BY	
ANGULAR	TITLE	DRAWING NUMBER	REVISION	MOLD NO.
	24 OZ. STOCK SPRAYER	SS-1650-OS		
	DATE			
	6/16/22			